



TREVALLI

TREVALLI SURGICAL

Quality is our Priority

ENT
INSTRUMENTS
2026



3 Oldham Place, Pietermaritzburg



083 555 8643



trevalli@mweb.co.za



TREVALLI

Standardinstrumente Basic Instruments Instrumentos básicos Instrumentes de base Strumenti di base	6-206
Skalpelle Scalpels Bisturies Bistouris Bisturi	6-9
Scheren Scissors Tijeras Ciseaux Forbic	10-42
Pinzetten Forceps Pinzas Pinces Pinze	43-62
Nadelhalter Needle holders Porta-agujas Porte-aiguilles Portaghi	63-78
Sonden · Watteträger · Punktion · Injektion · Sauginstrumente Probes · Cotton Carriers · Puncture · Injection · Suction Instruments Estiletos · Porta-algodones · Punción · Inyección · Instrumentos de aspiración Stylets · Porte-coton · Ponction · Injection · Instruments d'aspiration Specilli · Portacotone · Puntura · Iniezione · Strumenti per aspirazione	79-91
Wundhaken · Lippen- und Wangenhalter Retractors · Lip and Cheek Retractors Separadores · Separadores para labios y mejillas Ecarteurs · Ecarteurs de lèvres et de joues Divaricatori · Divaricatori per labbra e guancie	92-114
Wundspreizer Self-retaining Retractors Separadores autoestáticos Ecarteurs autostatiques Divaricatori autostatici	115-119
Nahtinstrumente Suture Sutura Suture Sutura	120-127
Klemmen · Zangen Forceps Pinzas Pinces Pinze	128-147
Knochenfeilen Bone Files Limas para huesos Limes à os Lime per ossa	148-149
Elevatorien Elevators Elevadores Elévateurs Elevatori	150-152



TREVALLi

Raspatorien Raspatories Legras Rugines Periostotomi	153-154
Hämmer · Flachmeißel · Hohlmeißel Mallets · Chisels · Gouges Martillos · Cinceles · Gubias Maillets · Ciseaux burins · Ciseaux gouges Martelli · Scalpelli · Sgorbie	155-159
Scharfe Löffel Sharp curettes Cucharillas cortantes Curettes tranchantes Cucchiai taglienti	160-163
Hohlmeißelzangen Bone Rongeurs Pinzas-gubias Pincers-gouges Pinze sgorbie	164-168
Knochensplitterzangen Bone Cutting Forceps Pinzas cortantes para huesos Pincers coupantes à os Pinze ossivore	169-170
Diagnostik Diagnostic Diagnóstico Diagnostic Diagnostica	171-195
Sterilisation Sterilization Esterilización Stérilisation Sterilizzazione	196-198
Edelstahlbehälter · Trays Stainless Steel Cases · Trays Recipientes de acero inoxidable · Bandejas Récipients en acier inoxydable · Cassettes Recipienti di acciaio inossidabile · Cassette	199-206
Otologie Otology Otología Otologie Otologia	207-267
Rhinologie · Septum - und Rhinoplastik · Sinuskopie Rhinology · Rhinoplasty · Sinuscopy Rinología · Septo y rinoplástica · Sinuscopia Rhinologie · Septo et rhinoplastie · Sinuscopie Rinologia · Settoplastica e rinoplastica · Sinoscopia	268-380



TREVALLi

Adenotomie · Tonsillektomie Adenoidectomy · Tonsillectomy Adenotomía · Amigdalotomía Adénotomie · Amygdalectomie Adenotomia · Tonsillectomia	381-417
Laryngoskopie · Bronchoskopie · Oesophagoskopie · Orale Endoskopie Laryngology · Bronchoscopy · Esophagoscopy · Oral Endoscopy Laringoscopia · Broncoscopia · Esofagoscopia · Endoscopia oral Laryngoscopie · Bronchoscopie · Oesophagoscopie · Endoscopie orale Laringoscopia · Broncoscopia · Esofagoscopia · Endoscopia orale	418-450
Tracheotomie · Strumektomie Tracheotomy · Thyroidectomy Traqueotomía · Tiroidectomia Trachéotomie · Thyroidectomie Tracheotomia · Tiroidectomia	451-458
Hochfrequenz-Chirurgie High Frequency Surgery Cirugía de alta frecuencia Chirurgie à haute fréquence Chirurgia ad alta frequenza	459-480
Siebvorschläge Set Suggestions Proposiciones de juegos Propositions pour boîtes Proposte di sets	481-533



TREVALLi

Unsere Instrumenten-Abbildungen haben eine Größe von ca. 50 %. Andere Darstellungsgrößen werden im Maßstab (zum Beispiel 1:1) angegeben. Die dazugehörigen Detailbilder sind in Originalgröße (100 %) abgebildet. Die angegebenen Bemaßungen unterliegen herstellungsbedingt einer Fertigungstoleranz.

In general the instrument illustrations are scaled to be approximately 50 % of actual size. If other scales are used they are indicated (for example 1:1). The corresponding detailed tip illustrations are shown in actual size (100 %). The stated measurements may have a slight variation in permissible tolerances due to minor variations in manufacturing conditions.

Las ilustraciones de los instrumentos tienen un tamaño de aprox. 50 %. Otros tamaños de las ilustraciones serán indicados con la indicación de un escala (por ejemplo 1:1). Los imagenes detallados pertinentes son en su tamaño original (100 %). Las dimensiones indicadas son sujeto de tolerancias.

Les illustrations de nos instruments sont à 50 % de la taille réelle. D'autres dimensions de représentation sont données avec indication d'échelle (par exemple 1:1). Les images de détail sont projetées en grandeur réelle (100 %). Toutes les dimensions données ont une tolérance de fabrication.

Le illustrazioni dei nostri strumenti hanno una dimensione del 50 %. Altre dimensioni di raffigurazione sono segnate con una scala (per esempio 1:1). Le relative illustrazioni dettagliate sono illustrate in dimensioni originali (100 %). Le dimensioni indicate sono soggette a una tolleranza di fabbricazione.

Beispiel
Example
Ejemplo
Exemple
Esempio

Vorderansicht (Schere gerade)
Front view (straight scissors)
Vista frontal (tijera recta)
Vue de face (ciseaux droits)
Vista frontale (forbice retta)

Seitenansicht (Schere gebogen)
Lateral view (curved scissors)
Vista lateral (tijera curva)
Vue laterale (ciseaux courbes)
Vista laterale (forbice curva)

14 cm – 5 1/2"	14 cm – 5 1/2"	
03.50.14	03.51.14	standard
203.50.14	203.51.14	supercut
213.50.14	213.51.14	blackline
03.50.64	03.51.64	"HM"
203.50.64	202.51.64	supercut plus
223.50.64	222.51.64	magiccut

1:1

Darstellungsgröße
Image sizes
Tamaño de representación
Dimension de représentation
Dimensione di raffigurazione

Instrumentengröße
Instrument size
Tamaño del instrumento
Taille des instruments
Dimensione degli strumenti

Artikelnummer
Item number
Número de artículo
Numéro d'article
Codice

Mayo



TREVALLi

ENT INSTRUMENTS

Standard instrumente
Basic Instruments
Instrumentos básicos
Instruments de base
Strumenti di base

trevalli@mweb.co.za



TREVALLi

1:1

Skalpelloklingen, Skalpellokgriffe
Scalpel Blades, Scalpel Handles
Hojas de bisturí, Mangos de bisturí Lames de
bistouris, Manches pour bistouris Lame per
bisturi, Manici per bisturi



Fig. 10 **01.22.10** P



Fig. 11 **01.22.11** P



Fig. 12 **01.22.12** P



Fig. 15 **01.22.15** P



Fig. 12d **01.22.32** P



Fig. 15c **01.22.35** P



12,5 cm - 5" **01.27.03** no. 3



21,0 cm - 8 1/4" **01.27.13** no. 3L

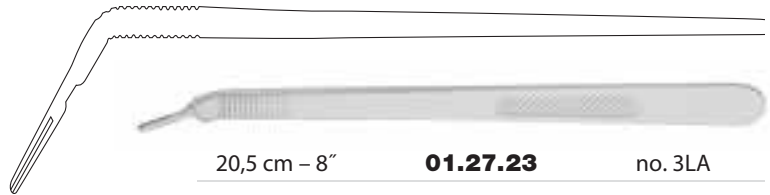

20,5 cm - 8" **01.27.23** no. 3LA



12,0 cm - 4 3/4" **01.27.17** no. 7K



16,5 cm - 6 1/2" **01.27.07** no. 7



15,5 cm - 6 1/8" **01.27.40** --



15,5 cm - 6 1/8" **01.30.38** Blake



22,5 cm - 9" **01.27.45**



STERILE



Einmalprodukt
Single use product
Producto para un solo uso
Produit à usage unique
Prodotto monouso



TREVALLi

1:1



Fig. 18 **01.22.18** P₁₀₀



Fig. 19 **01.22.19** P₁₀₀

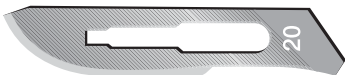

Fig. 20 **01.22.20** P₁₀₀



Fig. 21 **01.22.21** P₁₀₀



Fig. 22 **01.22.22** P₁₀₀



Fig. 23 **01.22.23** P₁₀₀



Fig. 24 **01.22.24** P₁₀₀



Fig. 25 **01.22.25** P₁₀₀



Fig. 36 **01.22.36** P₁₀₀

Skalpellklingen, Skalpellgriffe Scalpel Blades, Scalpel Handles Hojas de bisturí, Mangos de bisturí Lames de bistouris, Manches pour bistouris Lame per bisturi, Manici per bisturi



13,5 cm - 5 3/8" **01.28.04** no. 4



21,0 cm - 8 1/4" **01.28.14** no. 4L

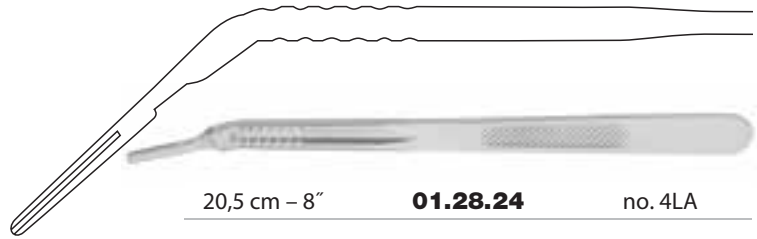

20,5 cm - 8" **01.28.24** no. 4LA



22,5 cm - 9" **01.28.45**

Verpackung für Skalpellklingen
Packing for scalpel blades
Paquete para hojas de bisturí
Emballage pour lames de bistouris
Confezione per bisturi



STERILE



Verpackungseinheit "X" Stück
Packing unit "X" pieces
Paquete de "X" unidades
Emballage de "X" pièces
Confezione da "X" pezzi



TREVALLi

1:1

Skalpellslingen, Skalpellsgriffe
Scalpel Blades, Scalpel Handles
Hojas de bisturí, Mangos de bisturí Lames de
bistouris, Manches pour bistouris Lame per
bisturi, Manici per bisturi



Fig. 62 **01.30.62** P₁₂



Fig. 64 **01.30.64** P₁₂



Fig. 65 **01.30.65** P₁₂



Fig. 67 **01.30.67** P₁₂



13,0 cm - 5 1/8" **01.30.32**

15,5 cm - 6 1/8" **01.30.36**



21 cm - 8 1/4" **01.27.21** Landolt



25 cm - 10" **01.27.25** Landolt



STERILE



Einmalprodukt
Single use product
Producto para un solo uso
Produit à usage unique
Prodotto monouso



Verpackungseinheit "X" Stück
Packing unit "X" pieces
Paquete de "X" unidades
Emballage de "X" pièces
Confezione da "X" pezzi



TREVALLi

Scheren
Scissors
Tijeras
Ciseaux
Forbici

SCISSORS

Von "standard" bis "magic cut" – alle Scheren werden von fachkundigen Chirurgiemechnikern hergestellt, für dauerhafte Leistung sorgfältig gehärtet und qualitätsgerecht geprüft. Die besonderen Eigenschaften unserer Sondermodelle sind auf den Folgeseiten dargestellt.

Starting with "standard" up to "magic cut" – all scissors are manufactured by experienced professionals. They are thoroughly hardened to ensure a long-lasting performance and are quality-checked. The specific characteristics of our special models are explained on the following pages.

Desde tijeras "standard" hasta "magic cut" – todas las tijeras son fabricadas por expertos competentes. Las tijeras son templadas e investigadas respecto a la calidad para un durable rendimiento. Las características de los modelos especiales son mencionadas en las paginas siguientes.

De "standard" à "magic cut" – tous les ciseaux sont fabriqués par des mécaniciens de chirurgie compétents, sont trempés soigneusement afin d'obtenir une performance durable et passent un contrôle de qualité. Les caractéristiques particulières de nos modèles spéciaux sont décrites sur les pages suivantes.

Dalla "standard" alla "magic cut" – tutte le forbici sono prodotte da meccanici chirurgici specializzati. Per una lunga durata sono temprate accuratamente e devono passare il controllo di qualità. Sulle prossime pagine sono illustrate le particolarità dei nostri modelli esclusivi.





TREVALLI

Scheren
Scissors
Tijeras
Ciseaux
Forbici

supercut

Goldene Schraube
Golden screw
Tornillo dorado
Vis dorée
Vite dorata



black line

Goldene Schraube und schwarze Ringgriffe
Golden screw and black rings
Tornillo dorado y anillos negros
Vis dorée et anneaux noirs
Vite dorata e anelli neri



"HM"

Goldene Ringgriffe
Golden rings
Anillos dorados
Anneaux dorés
Anelli dorati



supercut plus

Goldene Schraube und goldene Ringgriffe
Golden screw and golden rings
Tornillo dorado y anillos dorados
Vis dorée et anneaux dorés
Vite dorata e anelli dorati



magic cut

Keramikbeschichtung und goldene Schraube
Ceramic coating and golden screw
Recubrimiento de cerámica y tornillo dorado
Couche céramique et vis dorée
Rivestimento di ceramica e vite dorata





TREVALLi

supercut



black line



"HM"



supercut plus



magic cut



Messerschliff und Mikroverzahnung: Feiner, minimal traumatisierender Schnitt
Knife edges and micro serration: Fine, minimally traumatizing cut
Hoja de bisturí y dentadura micro: Corte fino, mínimo traumatizante
Aiguisement tranchant et dents micro: Coupe fine, peu traumatisante
Affilatura a scalpello e dentellatura micro: Taglio fine, minimo traumatizzante

Zusätzlicher Anschlag einer Blattrückseite: Bessere Sicht · Präzise Präparation
Reduction of the transversal cut: Better visibility · Precise dissection
Reducción del corte transversal: Vista mejorada · Disección precisa
Coupe transversale réduite: Vue améliorée · Dissection précise
Riduzione del taglio trasversale: Vista migliorata · Dissezione precisa

Eingeschweißte Hartmetallschneiden: Nahtlose, homogene und korrosionsfreie Verbindung von Hartmetall und Scherenstahl

Welded tungsten carbide cutting edges: Seamless, homogenous and corrosion-free junction of tungsten carbide and scissors steel

Hojas soldadas de carburo de tungsteno: Unión sin costuras, homogénea y resistente a la corrosión del carburo de tungsteno con el acero

Lames soudées d'un alliage de carbure de tungstène: Jointure sans trace, homogène et résistante à la corrosion du carbure de tungstène avec l'acier des ciseaux

Lame saldate al carburo di tungsteno: Congiunzione senza cordolo, omogenea e resistente alla corrosione del carburo di tungsteno con l'acciaio delle forbici

Keramikbeschichtung: Lange Standzeit · Hohe Oberflächenhärte · Blendfreie Oberfläche · Hervorragende Gleitfähigkeit

Ceramic coating: Long lasting cutting ability · High surface hardness · Non-dazzling surface · Excellent sliding capacity

Recubrimiento de cerámica: Máxima duración del corte · Alta dureza de la superficie · Superficie antideslumbrante · Deslizamiento destacado

Couche céramique: Longue durée de vie · Grande dureté de la surface · Surface non-éblouissante · Glissement excellent

Rivestimento di ceramica: Massima durata del taglio · Alta durezza della superficie · Superficie antiriflesso · Eccellente scorrimento



TREVALLi

Feine Scheren
Delicate Scissors
Tijeras finas
Ciseaux délicats
Forbici delicate



9,0 cm - 3 1/2"	10,5 cm - 4 1/8"	9,0 cm - 3 1/2"	10,5 cm - 4 1/8"	
02.04.09	02.04.10	02.05.09	02.05.10	standard



11 cm - 4 3/8"	11 cm - 4 3/8"	
02.06.10	02.07.10	standard
202.06.10	202.07.10	supercut
212.06.10	212.07.10	black line







TREVALLi

Feine Scheren
Delicate Scissors
Tijeras finas
Ciseaux délicats
Forbici delicate







Iris

				
9,0 cm - 3 1/2"	10,5 cm - 4 1/8"	11,5 cm - 4 1/2"	12,5 cm - 5"	
02.20.09	02.20.10	02.20.11	02.20.12	standard
	202.20.10	202.20.11		supercut
	212.20.10	212.20.11		black line
		02.20.61		"HM"
		202.20.61		supercut plus
		222.20.61		magic cut



Iris

				
9,0 cm - 3 1/2"	10,5 cm - 4 1/8"	11,5 cm - 4 1/2"	12,5 cm - 5"	
02.21.09	02.21.10	02.21.11	02.21.12	standard
	202.21.10	202.21.11	202.21.12	supercut
	212.21.10	212.21.11		black line
		02.21.61		"HM"
		202.21.61		supercut plus
		222.21.61		magic cut



TREVALLi

**Feine Scheren
Delicate Scissors
Tijeras finas
Ciseaux délicats
Forbici delicate**



Micro-Iris



9 cm - 3 1/2"

02.20.30



9 cm - 3 1/2"

02.21.30

standard

202.21.30

supercut



Iris-Select



10,5 cm - 4 1/8"

02.20.40



10,5 cm - 4 1/8"

02.21.40

standard



BIG RING
X-Large Ring Handle



"BIG RING"

Iris



11,5 cm - 4 1/2"

212.26.11



11,5 cm - 4 1/2"

212.27.11

black line



TREVALLi

Feine Scheren
Delicate Scissors
Tijeras finas
Ciseaux délicats
Forbici delicate



Stevens



11,5 cm - 4 1/2"

02.50.02



11,5 cm - 4 1/2"

02.50.03

standard



Stevens



11,5 cm - 4 1/2"

02.50.12



11,5 cm - 4 1/2"

02.50.13

standard

202.50.12

202.50.13

supercut

212.50.12

212.50.13

black line

222.50.62

222.50.63

magic cut



TREVALLi

Feine Scheren
Delicate Scissors
Tijeras finas
Ciseaux délicats
Forbici delicate



Knapp



12 cm - 4 3/4"

02.20.42

202.20.42



12 cm - 4 3/4"

02.21.42

202.21.42



12 cm - 4 3/4"

02.20.43



12 cm - 4 3/4"

02.21.43

standard

supercut



Lexer-Baby



10 cm - 4"

02.40.10

02.40.60



10 cm - 4"

02.41.10

02.41.60

standard

"HM"



Shea



12 cm - 4 3/4"

04.13.12

204.13.12

214.13.12

standard

supercut

black line



spitz
sharp
aguda
pointu
acuta



stumpf
blunt
roma
mousse
smussa



TREVALLi

Feine Präparierscheren
Delicate Dissecting Scissors
Tijeras finas para disección
Ciseaux délicats à dissection
Forbici delicate per dissezione



12 cm - 4 3/4"

12 cm - 4 3/4"

02.40.12	02.41.12	standard
202.40.12	202.41.12	supercut
212.40.12	212.41.12	black line
02.40.62	02.41.62	"HM"
202.40.62	202.41.62	supercut plus
222.40.62	222.41.62	magic cut



Ragnell (Kilner)

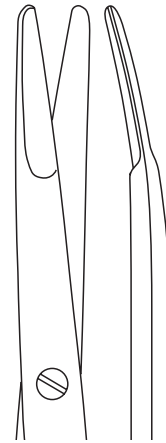

13 cm - 5 1/8"

15 cm - 6"

18 cm - 7 1/8"

20 cm - 8"

04.13.13	04.13.15	04.13.18	04.13.20	standard
204.13.13	204.13.15	204.13.18		supercut
214.13.13	214.13.15	214.13.18		black line
04.13.63	04.13.65	04.13.68		"HM"
204.13.63	204.13.65	204.13.68		supercut plus



TREVALLi

Feine Präparierscheren
Delicate Dissecting Scissors
Tijeras finas para disección
Ciseaux délicats à dissection
Forbici delicate per dissezione



Baby-Metzenbaum



11,5 cm - 4 1/2"



11,5 cm - 4 1/2"

04.32.11	04.33.11	standard
204.32.11	204.33.11	supercut
214.32.11	214.33.11	black line
04.32.61	04.33.61	"HM"
204.32.61	204.33.61	supercut plus
224.32.61	224.33.61	magic cut



"slim"



14 cm - 5 1/2"



14 cm - 5 1/2"

04.24.14	04.25.14	standard
204.24.14	204.25.14	supercut
04.24.64	04.25.64	"HM"
204.24.64	204.25.64	supercut plus



TREVALLi

Feine Präparierscheren
Delicate Dissecting Scissors
Tijeras finas para disección
Ciseaux délicats à dissection
Forbici delicate per dissezione



Sanvenero

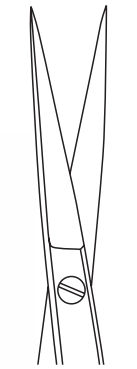

14 cm - 5 1/2"

04.50.14



14 cm - 5 1/2"

04.51.14

standard



Greenberg PAR



11,5 cm - 4 1/2"

204.13.62

supercut plus

224.13.62

magic cut



BIG RING

X-Large Ring Handle



"BIG RING"

Baby-Metzenbaum



11,5 cm - 4 1/2"

214.36.11



11,5 cm - 4 1/2"

214.37.11

black line



TREVALLi

**Feine Präparierscheren
Delicate Dissecting Scissors
Tijeras finas para disección
Ciseaux délicats à dissection
Forbici delicate per dissezione**



Joseph



15 cm - 6"



15 cm - 6"

04.50.15	04.51.15	standard
204.50.15	204.51.15	supercut
214.50.15	214.51.15	black line



"BIG RING"

Stevens



12,5 cm - 5"



12,5 cm - 5"

214.68.13	214.69.13	black line
------------------	------------------	------------



TREVALLI

**Feine Präparierscheren
Delicate Dissecting Scissors
Tijeras finas para disección
Ciseaux délicats à dissection
Forbici delicate per dissezione**

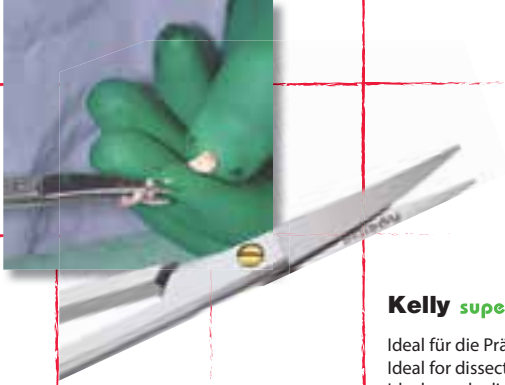

Kelly supercut plus

Ideal für die Präparation der Nasenflügelknorpel und der gesamten Schleimhaut.
Ideal for dissecting alar cartilage and the complete mucosa.
Ideal para la disección del cartilago de las alas y para la mucosa completa.
Idéal pour la dissection du cartilage des ailes et de la muqueuse complète.
Ideale per la dissezione della cartilagine delle alette e della mucosa completa.



Kelly



16 cm - 6 1/4"

04.54.16

204.54.16

214.54.16

04.54.66

204.54.66

224.54.66



16 cm - 6 1/4"

04.55.16

204.55.16

214.55.16

04.55.66

204.55.66

224.55.66

standard

supercut

black line

"HM"

supercut plus

magic cut

Feine Präparierscheren
Delicate Dissecting Scissors
Tijeras finas para disección
Ciseaux délicats à dissection
Forbici delicate per dissezione

Nervpräparierscheren
 Nerve dissecting scissors
 Tijeras para disección de nervios
 Ciseaux à dissection pour nerfs
 Forbici per dissezione dei nervi



Stevens



13 cm - 5 1/8"

04.67.13	standard
204.67.13	supercut
214.67.13	black line
224.67.63	magic cut

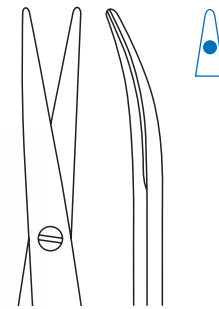

15 cm - 6"

04.67.15	standard
204.67.15	supercut
214.67.15	black line
204.67.65	supercut plus

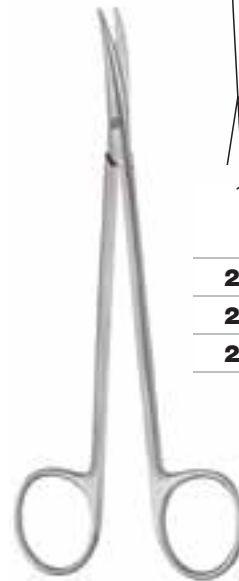

halbstumpf
 semi blunt
 semi roma
 semi mousse
 semi smussa



TREVALLi

Präparierscheren
Dissecting Scissors
Tijeras para disección
Ciseaux à dissection
Forbici per dissezione



Mayo supercut plus



Mayo

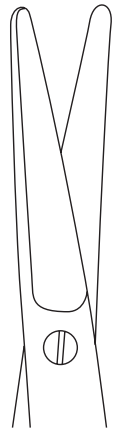

14 cm - 5 1/2"

03.50.14

203.50.14

213.50.14

03.50.64

203.50.64

223.50 .64



14 cm - 5 1/2"

03.51.14

203.51.14

213.51.14

03.51.64

203.51.64

223.51.64

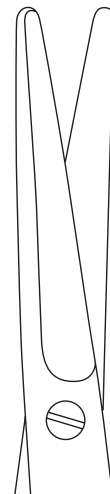

17 cm - 6 3/4"

03.50.17

203.50.17

213.50.17

03.50.67

203.50.67

223.50.67



17 cm - 6 3/4"

03.51.17

203.51.17

213.51.17

03.51.67

203.51.67

223.51.67

standard

supercut

black line

"HM"

supercut plus

magic cut



TREVALLi

Präparierscheren
Dissecting Scissors
Tijeras para disección
Ciseaux à dissection
Forbici per dissezione



Mayo-Lexer



16,5 cm - 6 1/2"

203.57.47 **supercut**

213.57.47 **black line**

03.57.97 **"HM"**

203.57.97 **supercut plus**

223.57.97 **magic cut**



Lexer



16 cm - 6 1/4"

16 cm - 6 1/4"

03.56.86 **03.57.86** **standard**

203.56.86 **203.57.86** **supercut**

213.56.86 **213.57.86** **black line**

03.56.96 **03.57.96** **"HM"**

203.56.96 **203.57.96** **supercut plus**

223.56.96 **223.57.96** **magic cut**



TREVALLi

Präparierscheren
Dissecting Scissors
Tijeras para disección
Ciseaux à dissection
Forbici per dissezione



03.57.67
Mayo-Style "HM"

Für präzises, druckloses Gipsschneiden direkt auf der Nase ohne Verschiebung des mobilisierten Nasengerüsts.
For precise, pressure-free plaster cutting directly on the nose without displacement of the mobilized nose framework.
Para el corte preciso y sin presión del yeso directamente sobre la nariz y sin desplazamiento del armazón de la nariz movilizado.
Pour une coupe précise et sans pression du plâtre directement sur le nez, sans décalage de la charpente nasale mobilisée.
Per tagliare con precisione il gesso direttamente sul naso senza esercitare pressione e senza spostare la struttura nasale mobile.



Mayo-Style

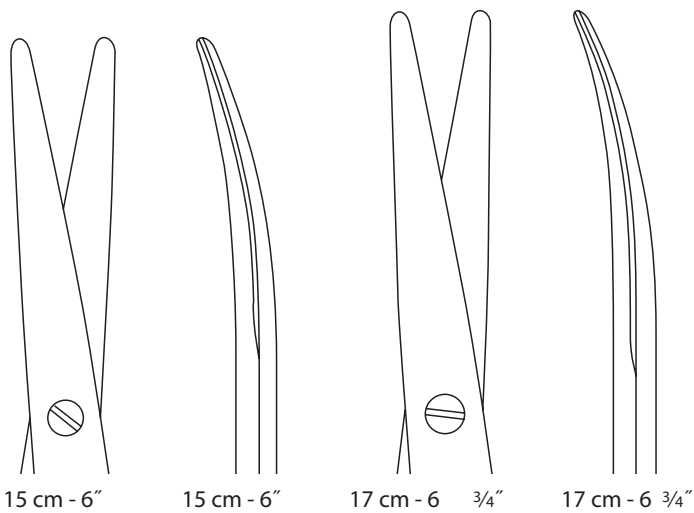

15 cm - 6"	15 cm - 6"	17 cm - 6 3/4"	17 cm - 6 3/4"	
03.56.15	03.57.15	03.56.17	03.57.17	standard
203.56.15	203.57.15	203.56.17	203.57.17	supercut
213.56.15	213.57.15	213.56.17	213.57.17	black line
03.56.65	03.57.65	03.56.67	03.57.67	"HM"
203.56.65	203.57.65	203.56.67	203.57.67	supercut plus
223.56.65	223.57.65	223.56.67	223.57.67	magic cut



TREVALLi

Präparierscheren
Dissecting Scissors
Tijeras para disección
Ciseaux à dissection
Forbici per dissezione



Metzenbaum-slim



14 cm - 5 1/2"

04.34.14

204.34.14

214.34.14

04.34.64

204.34.64



18 cm - 7 1/8"

04.34.18

204.34.18

214.34.18

04.34.68

204.34.68



14 cm - 5 1/2"

04.35.14

204.35.14

214.35.14

04.35.64

204.35.64

224.35.64



18 cm - 7 1/8"

04.35.18

204.35.18

214.35.18

04.35.68

204.35.68

224.35.68

standard

supercut

black line

"HM"

supercut plus

magic cut



Metzenbaum



14 cm - 5 1/2"

04.32.14

204.32.14

214.32.14

04.32.64

204.32.64

224.32.64



18 cm - 7 1/8"

04.32.18

204.32.18

214.32.18

04.32.68

204.32.68

224.32.68

standard

supercut

black line

"HM"

supercut plus

magic cut



TREVALLi

Präparierscheren
Dissecting Scissors
Tijeras para disección
Ciseaux à dissection
Forbici per dissezione



Metzenbaum

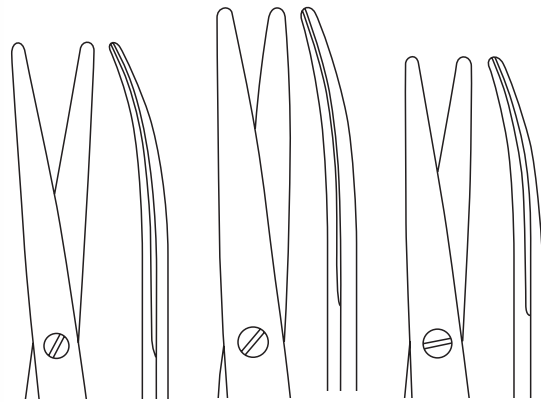

14 cm - 5 1/2"

15 cm - 6"

18 cm - 7 1/8"

04.33.14	04.33.15	04.33.18	standard
204.33.14	204.33.15	204.33.18	supercut
214.33.14	214.33.15	214.33.18	black line
04.33.64		04.33.68	"HM"
204.33.64		204.33.68	supercut plus
224.33.64		224.33.68	magic cut



Metzenbaum

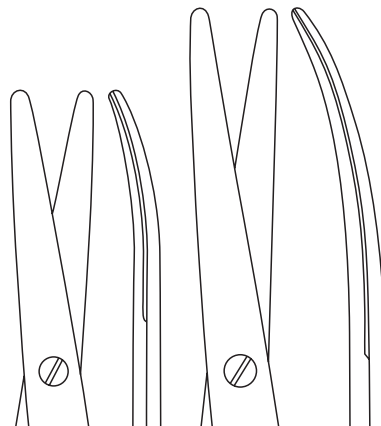

18 cm - 7 1/8"

20 cm - 8"

204.36.18	204.36.20	supercut
214.36.18	214.36.20	black line
04.36.68	04.36.70	"HM"
204.36.68	204.36.70	supercut plus



TREVALLi

Präparierscheren
Dissecting Scissors
Tijeras para disección
Ciseaux à dissection
Forbici per dissezione



Metzenbaum-Freeman

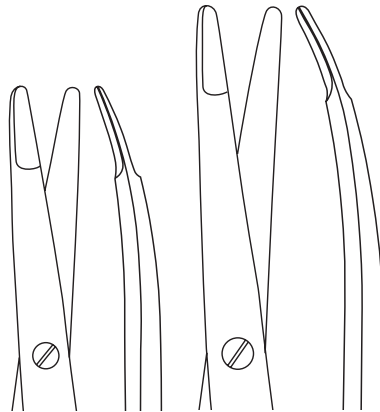

18 cm - 7 1/8"

20 cm - 8"

204.37.18

204.37.20

supercut

214.37.18

214.37.20

black line



Reynolds (Jameson)



12 cm - 4 3/4"



14 cm - 5 1/2"



16 cm - 6 1/4"



18 cm - 7 1/8"

04.67.12

04.67.14

04.67.16

04.67.18

standard

204.67.12

204.67.16

204.67.18

supercut

214.67.12

214.67.16

214.67.18

black line

224.67.66

224.67.68

magic cut



TREVALLi

Präparierscheren
Dissecting Scissors
Tijeras para disección
Ciseaux à dissection
Forbici per dissezione



House-Toennis



18 cm - 7 1/8"

04.60.18 standard



Toennis



18 cm - 7 1/8"

04.61.18 standard



Toennis-Adson

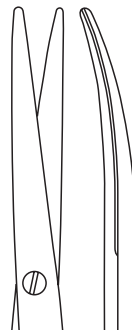

18 cm - 7 1/8"

04.63.18 standard

204.63.18 supercut

214.63.18 black line

04.63.68 "HM"

204.63.68 supercut plus

224.63.68 magic cut



TREVALLi

Präparierscheren
Dissecting Scissors
Tijeras para disección
Ciseaux à dissection
Forbici per dissezione



Facelift



Gorney

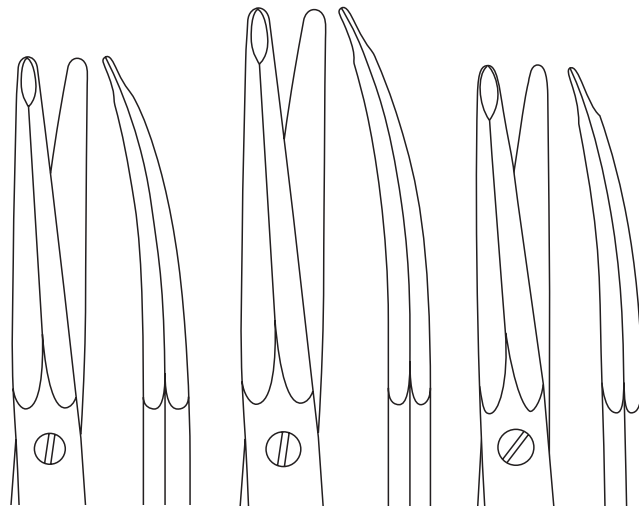

17 cm - 6 3/4"

19 cm - 7 1/2"

23 cm - 9"

204.73.17	204.73.19	204.73.23	supercut
214.73.17	214.73.19	214.73.23	black line
04.73.67	04.73.69	04.73.73	"HM"
224.73.67	224.73.69	224.73.73	magic cut



TREVALLI



Facelift

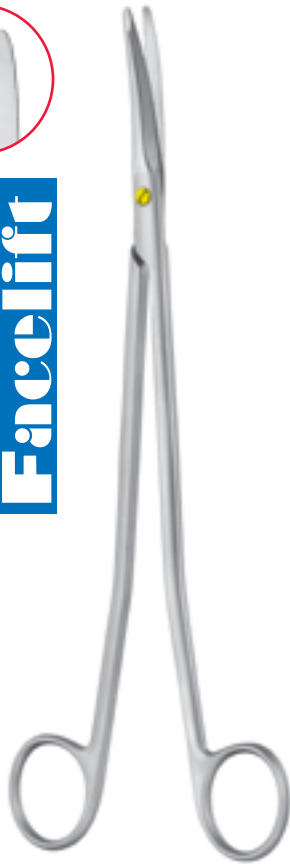

Gorney-Freeman

flache Spitzen
flat tips
puntas planas
pointes plates
punte piatte

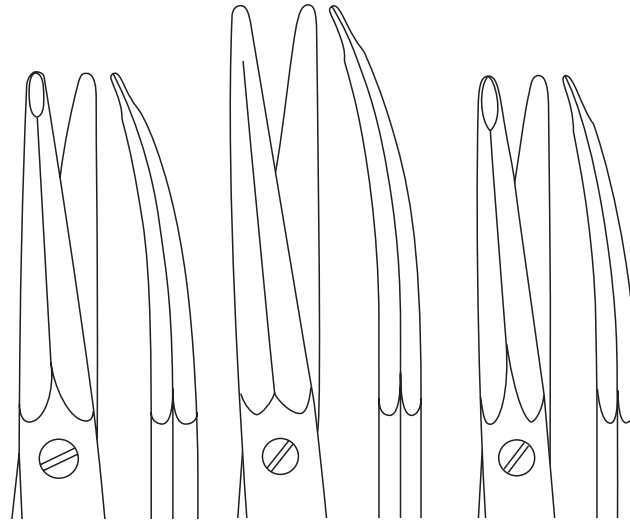

17 cm - 6 3/4"

19 cm - 7 1/2"

23 cm - 9"

204.75.17

204.75.19

204.75.23

supercut

214.75.17

214.75.19

214.75.23

black line

04.75.67

04.75.69

04.75.73

"HM"

224.75.67

224.75.69

224.75.73

magic cut



Gorney-Freeman

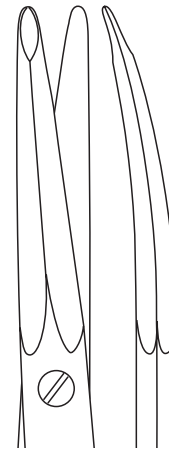

23 cm - 9"

204.75.22

supercut

214.75.22

black line

04.75.72

"HM"

224.75.72

magic cut



TREVALLi

Facelift



Kaye

Präparierscheren
Dissecting Scissors
Tijeras para disección
Ciseaux à dissection
Forbici per dissezione

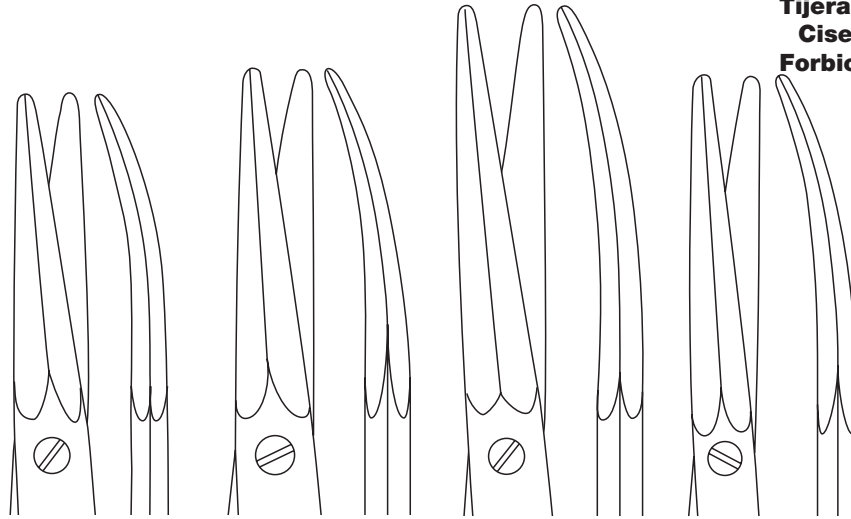

15 cm - 6"

17 cm - 6 3/4"

19 cm - 7 1/2"

23 cm - 9"

204.77.15

204.77.17

204.77.19

204.77.23

supercut

214.77.15

214.77.17

214.77.19

214.77.23

black line

04.77.67

04.77.69

04.77.73

"HM"

224.77.67

224.77.69

224.77.73

magic cut

Blepharoplastikscheren
Blepharoplasty scissors
Tijeras para blefaroplastia
Ciseaux pour bléfaroplastie
Forbici per blefaroplastica



Kaye



11,5 - 4 1/2"

204.77.12

supercut

214.77.12

black line



TREVALLi

Chirurgische Scheren
 Operating Scissors
 Tijeras quirúrgicas
 Ciseaux chirurgicaux
 Forbici chirurgiche

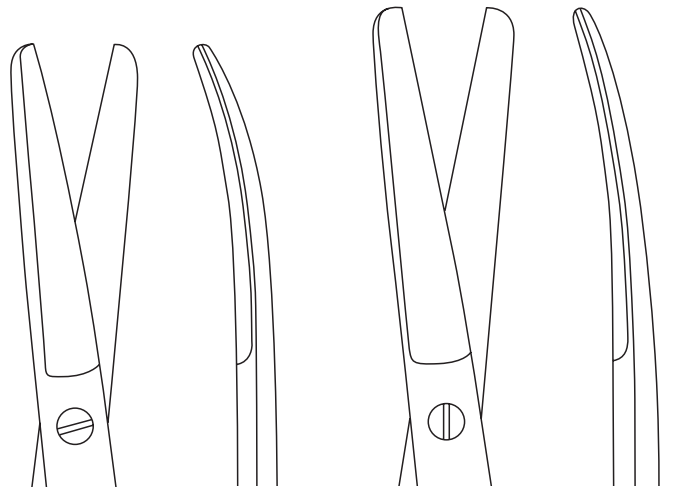

13 cm – 5 1/8"

13 cm – 5 1/8"

14,5 cm – 5 3/4"

14,5 cm – 5 3/4"

03.02.13

03.03.13

03.02.14

03.03.14

standard

203.02.13

203.03.13

203.02.14

203.03.14

supercut

213.02.14

213.03.14

black line

03.02.64

03.03.64

"HM"



13 cm – 5 1/8"

13 cm – 5 1/8"

14,5 cm – 5 3/4"

14,5 cm – 5 3/4"

03.04.13

03.05.13

03.04.14

03.05.14

standard

203.04.13

203.05.13

203.04.14

203.05.14

supercut

213.04.14

213.05.14

black line

03.04.64

03.05.64

"HM"



TREVALLi

Chirurgische Scheren
Operating Scissors
Tijeras quirúrgicas
Ciseaux chirurgicaux
Forbici chirurgiche

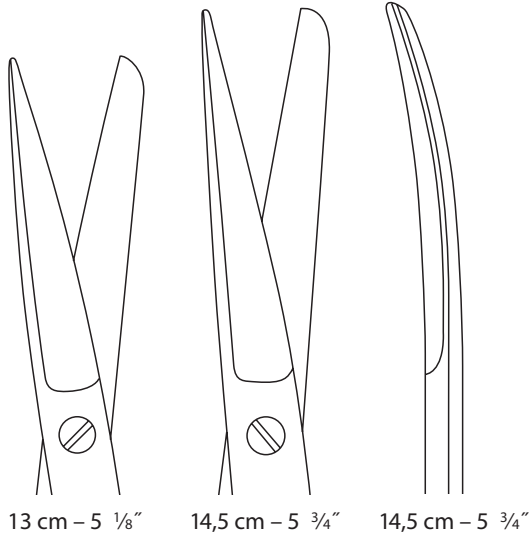

13 cm - 5 1/8"

14,5 cm - 5 3/4"

14,5 cm - 5 3/4"

03.06.13	03.06.14	03.07.14	standard
203.06.13	203.06.14	203.07.14	supercut
	213.06.14	213.07.14	black line
	03.06.64	03.07.64	"HM"



Fox

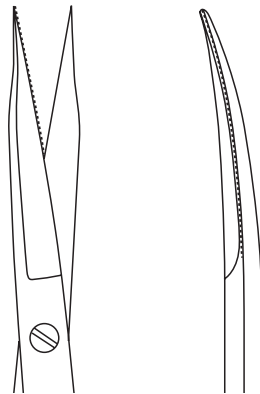

13 cm - 5 1/8"

13 cm - 5 1/8"

04.80.13	04.81.13	standard	
204.80.13	204.81.13	supercut	
214.80.13	214.81.13	black line	
04.80.63	04.81.63	"HM"	
204.80.63	204.81.63	supercut plus	



Eine Schneide gezahnt
 One blade serrated
 Una hoja dentada
 Une lame dentelée
 Una lama dentellata



TREVALLi

Mikro Scheren
Micro Scissors
Micro tijeras
Micro ciseaux
Micro forbici



micro 2000



12,5 cm - 5"

05.12.20

205.12.20

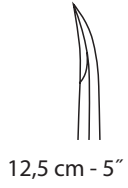

12,5 cm - 5"

05.12.21

205.12.21

gezahnte Schneiden
serrated cutting edges
hojas dentadas
lames dentelées
lame dentellate

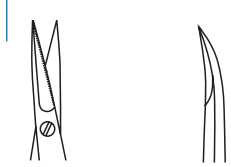

12,5 cm - 5"

05.12.22

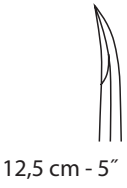

12,5 cm - 5"

05.12.23

Vannas Schneiden
Vannas-type cutting edges
hojas según Vannas
lames selon Vannas
lame secondo Vannas



12,5 cm - 5"

05.12.30

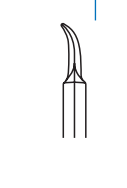

12,5 cm - 5"

05.12.31

standard
supercut



micro 2000

gezahnte Schneiden
serrated cutting edges
hojas dentadas
lames dentelées
lame dentellate

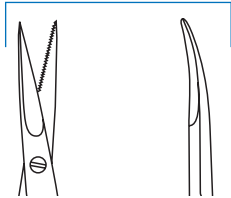

15 cm - 6"

05.15.22

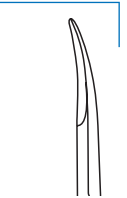

15 cm - 6"

05.15.23

Vannas-Schneiden
Vannas-type cutting edges
hojas según Vannas
lames selon Vannas
lame secondo Vannas

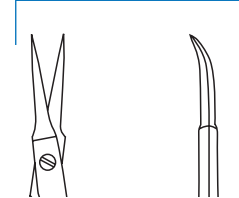

15 cm - 6"

05.15.30

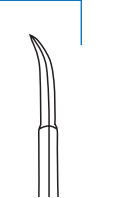

15 cm - 6"

05.15.31

standard



micro 2000



15 cm - 6"

05.15.20

205.15.20



15 cm - 6"

05.15.21

205.15.21

standard
supercut



TREVALLi

Mikro Scheren
Micro Scissors
Micro tijeras
Micro ciseaux
Micro forbici

gezahnte Schneiden
serrated cutting edges
hojas dentadas
lames dentelées
lame dentellate



micro 2000

15 cm - 6"	15 cm - 6"	15 cm - 6"	15 cm - 6"	
05.15.70	05.15.71	05.15.72	05.15.73	standard
18 cm - 7 1/8"	18 cm - 7 1/8"	18 cm - 7 1/8"	18 cm - 7 1/8"	
05.18.70	05.18.71	05.18.72	05.18.73	standard
205.18.70	205.18.71			supercut

Leichtmetall-Instrumente mit blau eloxierten Rundgriffen
Light-weight instruments with blue anodized round handles
Instrumentos de metal ligero con mangos redondos anodizados azul
Instruments en métal léger, avec manches ronds anodisés en bleu
Strumenti di metallo leggero con manici rotondi, anodizzati blu

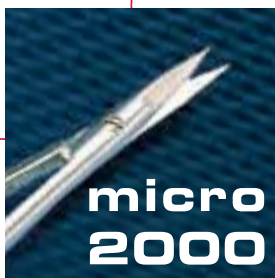

- geringes Gewicht
- gut ausbalanciert
- ermüdungsfreies Arbeiten
- extremely light weight
- well balanced
- fatigueless working
- peso muy ligero
- bien equilibrados
- trabajo sin fatiga
- poids léger
- bien équilibrés
- travail sans fatigue
- peso minimo
- equilibrio perfetto
- non affaticano la mano



TREVALLi

Mikro Scheren
Micro Scissors
Micro tijeras
Micro ciseaux
Micro forbici



micro 2000



15 cm - 6"

05.15.81



15 cm - 6"

05.15.83

standard

18 cm - 7 1/8"

05.18.81

18 cm - 7 1/8"

05.18.83

standard

Vannas-Schneiden
Vannas-type cutting edges
hojas según Vannas
lames selon Vannas
lame secondo Vannas



15 cm - 6"

05.15.74



15 cm - 6"

05.15.75



15 cm - 6"

05.15.76



15 cm - 6"

05.15.77

standard

205.15.74

supercut



8 mm
Rundgriff
Round handle
Mango redondo
Manche rond
Manico rotondo



TREVALLi

Mikro Scheren
Micro Scissors
Micro tijeras
Micro ciseaux
Micro forbici



18 cm - 7 1/8"	18 cm - 7 1/8"	18 cm - 7 1/8"	18 cm - 7 1/8"	18 cm - 7 1/8"	
05.19.25	05.19.45	05.19.60	05.19.90	05.19.95	"HM"
225.19.25	225.19.45	225.19.60	225.19.90	225.19.95	magic cut



18 cm - 7 1/8"	18 cm - 7 1/8"	18 cm - 7 1/8"	18 cm - 7 1/8"	18 cm - 7 1/8"	
05.21.25	05.21.45	05.21.60	05.21.90	05.21.95	"HM"

8 mm

 Rundgriff
 Round handle
 Mango redondo
 Manche rond
 Manico rotondo



TREVALLi



Rundgriff
Round handle
Mango redondo
Manche rond
Manico rotondo

Mikro Scheren
Micro Scissors
Micro tijeras
Micro ciseaux
Micro forbici



15 cm - 6"

05.16.74



15 cm - 6"

05.16.75

18 cm - 7 1/8"

05.18.74

18 cm - 7 1/8"

05.18.75

21 cm - 8 1/4"

05.21.74

21 cm - 8 1/4"

05.21.75



15 cm - 6"

05.16.68



15 cm - 6"

05.16.69

18 cm - 7 1/8"

05.18.68

18 cm - 7 1/8"

05.18.69

21 cm - 8 1/4"

05.21.68

21 cm - 8 1/4"

05.21.69



TREVALLI

Verbandscheren
Bandage Scissors
Tijeras para vendajes
Ciseaux à pansements
Forbici per bendaggi



Lister

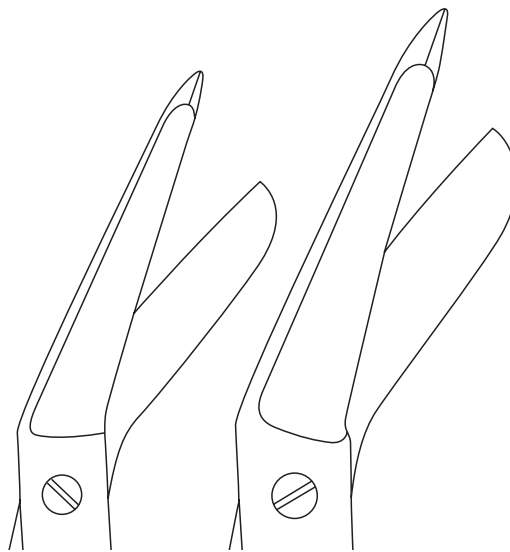

14 cm - 5 ½"

18 cm - 7 ⅛"

40.25.14

40.25.18

standard

240.25.14

240.25.18

supercut

40.25.64

40.25.68

"HM"



TREVALLi

**Anatomische Pinzetten
Dressing Forceps
Pinzas anatómicas
Pincés anatomiques
Pinze anatomiche**



9 cm - 3½"

06.00.09



10,5 cm - 4 1/8"

06.00.10



11,5 cm - 4½"

06.00.11



13 cm - 5 1/8"

06.00.13



14,5 cm - 5¾"

06.00.14

Standard
standard
estándar
standard
standard



15 cm - 6"

06.00.15



16 cm - 6¼"

06.00.16



18 cm - 7 1/8"

06.00.18



20 cm - 8"

06.00.20



25 cm - 10"

06.00.25



30 cm - 11¾"

06.00.30





TREVALLi

**Chirurgische Pinzetten
Tissue Forceps
Pinzas quirúrgicas
Pinces chirurgicales
Pinze chirurgiche**

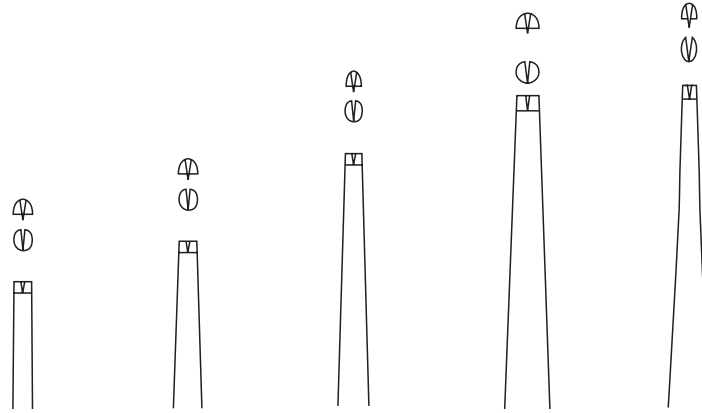

10,5 cm - 4 1/8" 11,5 cm - 4 1/2" 13 cm - 5 1/8" 14,5 cm - 5 3/4" 15 cm - 6"
06.05.10 06.05.11 06.05.13 06.05.14 06.05.15

Standard
standard
estándar
standard
standard

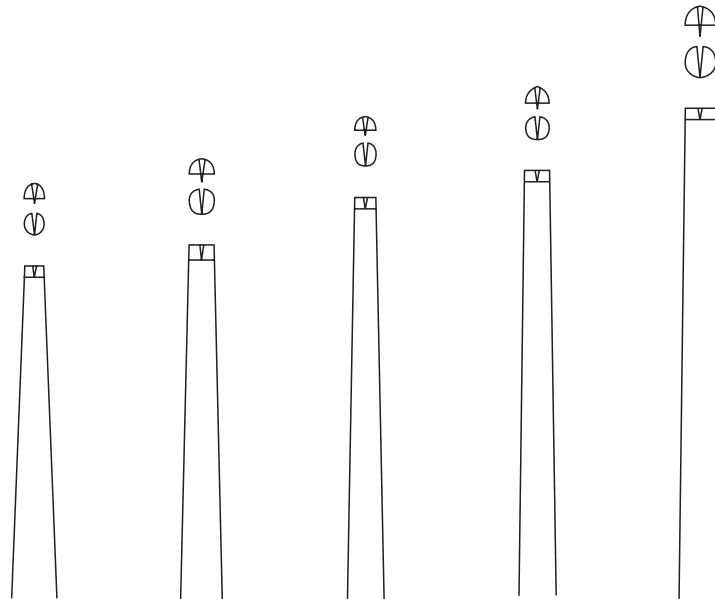

16 cm - 6 1/4" 18 cm - 7 1/8" 20 cm - 8" 25 cm - 10" 30 cm - 11 3/4"
06.05.16 06.05.18 06.05.20 06.05.25 06.05.30



TREVALLi

**Anatomische und chirurgische Pinzetten
Dressing and Tissue Forceps
Pinzas anatómicas y quirúrgicas
Pinces anatomiques et chirurgicales
Pinze anatomiche e chirurgiche**



mittelbreit
medium width
de anchura media
demi-large
di media larghezza

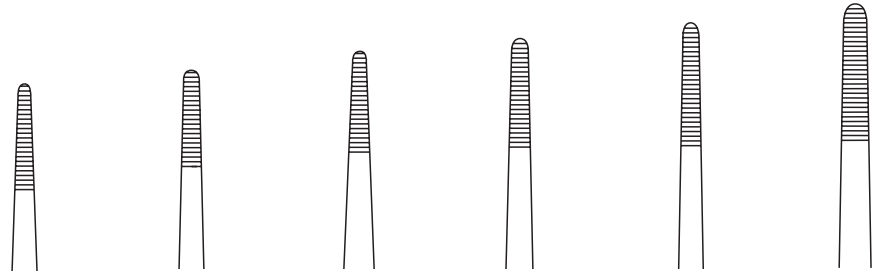

10,5 cm - 4 1/8"	11,5 cm - 4 1/2"	13 cm - 5 1/8"	14,5 cm - 5 3/4"	16 cm - 6 1/4"	18 cm - 7 1/8"
06.01.10	06.01.11	06.01.13	06.01.14	06.01.16	06.01.18

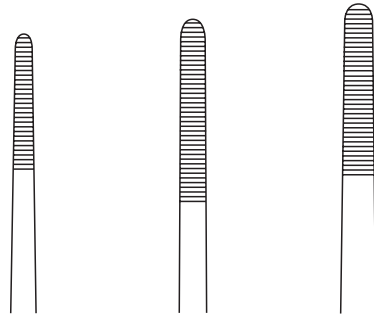

20 cm - 8"	25 cm - 10"	30 cm - 11 3/4"
06.01.20	06.01.25	06.01.30

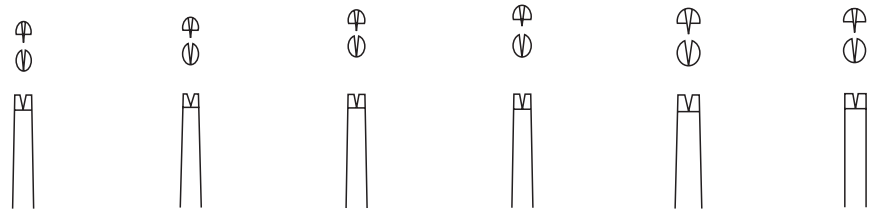

11,5 cm - 4 1/2"	13 cm - 5 1/8"	14,5 cm - 5 3/4"	16 cm - 6 1/4"	18 cm - 7 1/8"	20 cm - 8"
06.06.11	06.06.13	06.06.14	06.06.16	06.06.18	06.06.20



TREVALLi

Anatomische und chirurgische Pinzetten
Dressing and Tissue Forceps
Pinzas anatómicas y quirúrgicas
Pinces anatomiques et chirurgicales
Pinze anatomiche e chirurgiche



11,5 cm - 4½"

13 cm - 5 1/8"

14,5 cm - 5¾"

15 cm - 6"

16 cm - 6¼"

18 cm - 7 1/8"

06.02.11

06.02.13

06.02.14

06.02.15

06.02.16

06.02.18



20 cm - 8"

25 cm - 10"

06.02.20

06.02.25



11,5 cm - 4½"

13 cm - 5 1/8"

14,5 cm - 5¾"

15 cm - 6"

16 cm - 6¼"

18 cm - 7 1/8"

06.07.11

06.07.13

06.07.14

06.07.15

06.07.16

06.07.18



20 cm - 8"

25 cm - 10"

06.07.20

06.07.25



schlank
slim
delgada
élancée
stretta



TREVALLI

Anatomische und chirurgische Pinzetten
Dressing and Tissue Forceps
Pinzas anatómicas y quirúrgicas
Pinces anatomiques et chirurgicales
Pinze anatomiche e chirurgiche

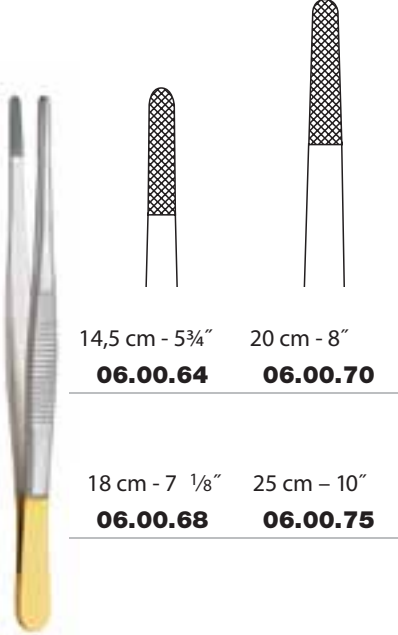

14,5 cm - 5¾"	20 cm - 8"
06.00.64	06.00.70
<hr/>	
18 cm - 7 1/8"	25 cm - 10"
06.00.68	06.00.75

"HM"

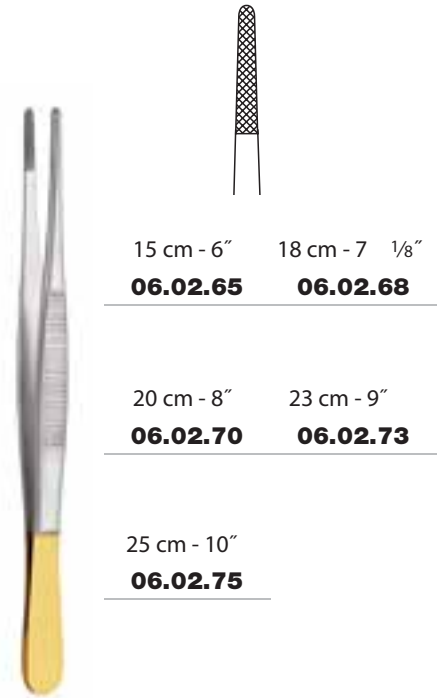

15 cm - 6"	18 cm - 7 1/8"
06.02.65	06.02.68
<hr/>	
20 cm - 8"	23 cm - 9"
06.02.70	06.02.73
<hr/>	
25 cm - 10"	
06.02.75	

Potts-Smith "HM"

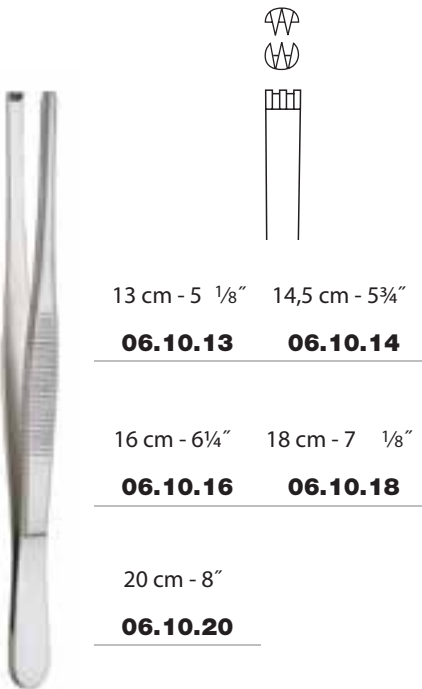

13 cm - 5 1/8"	14,5 cm - 5¾"
06.10.13	06.10.14
<hr/>	
16 cm - 6¼"	18 cm - 7 1/8"
06.10.16	06.10.18
<hr/>	
20 cm - 8"	
06.10.20	

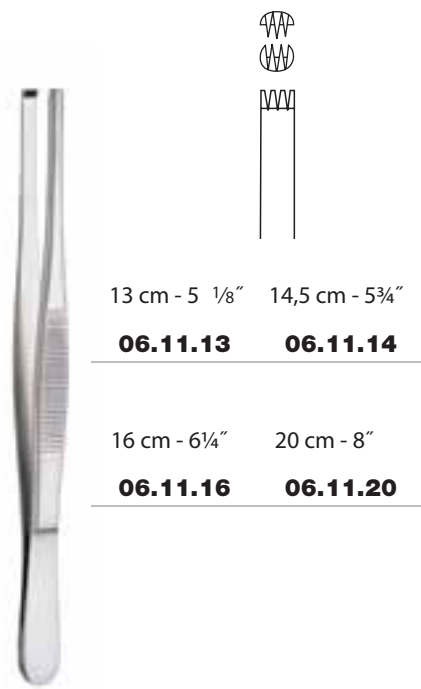

13 cm - 5 1/8"	14,5 cm - 5¾"
06.11.13	06.11.14
<hr/>	
16 cm - 6¼"	20 cm - 8"
06.11.16	06.11.20

"HM" Hartmetall
 Tungsten carbide
 Carburo de tungsteno
 Carbure de tungstène
 Carburo di tungsteno



TREVALLI

Feine Pinzetten, anatomisch und chirurgisch
Delicate Forceps, dressing and tissue
Pinzas finas, anatómicas y quirúrgicas
Pincas délicates, anatomiques et chirurgicales
Pinze delicate, anatomiche e chirurgiche

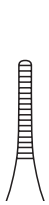

12 cm - 4¾"

06.20.01

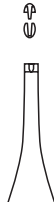

12 cm - 4¾"

06.20.05

Hudson-Ewald



12 cm - 4¾"

06.21.12

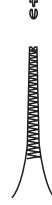

12 cm - 4¾"

06.21.13

Adson



12 cm - 4¾"

06.21.62

Adson "HM"

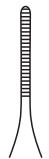

12 cm - 4¾"

06.20.12



15 cm - 6"

06.21.15

Adson



12 cm - 4¾"

06.20.62

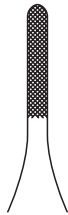

15 cm - 6"

06.20.65

Adson "HM"

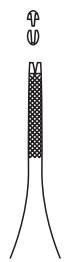

15 cm - 6"

06.21.65

Adson "HM"

"HM"
Hartmetall
Tungsten carbide
Carburo de tungsteno
Carbure de tungstène
Carburo di tungsteno



TREVALLi

Feine Pinzetten, anatomisch und chirurgisch
Delicate Forceps, dressing and tissue
Pinzas finas, anatómicas y quirúrgicas
Pincas délicates, anatomiques et chirurgicales
Pinze delicate, anatomiche e chirurgiche



Micro-Adson



12 cm - 4 3/4"

06.22.12



12 cm - 4 3/4"

06.23.12



15 cm - 6"

06.22.15



15 cm - 6"

06.23.15



Adson-Brown

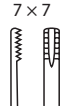

7 x 7

12 cm - 4 3/4"

06.25.12

Zähne
Teeth
Dientes
Dents
Denti

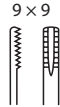

9 x 9

12 cm - 4 3/4"

06.25.15



Adson-Brown



9 x 9

12 cm - 4 3/4"

06.25.72

Zähne
Teeth
Dientes
Dents
Denti



TREVALLi

Feine Pinzetten, anatomisch und chirurgisch
Delicate Forceps, dressing and tissue
Pinzas finas, anatómicas y quirúrgicas
Pinces délicates, anatomiques et chirurgicales
Pinze delicate, anatomiche e chirurgiche



10 cm - 4"

06.30.10



10 cm - 4"

06.30.20



10 cm - 4"

06.30.30



10 cm - 4"

06.31.10



10 cm - 4"

06.31.20



10 cm - 4"

06.31.30



12,5 cm - 5"

06.30.12



12,5 cm - 5"

06.30.22



15 cm - 6"

06.30.15



15 cm - 6"

06.30.25

Semken



12,5 cm - 5"

06.31.12



12,5 cm - 5"

06.31.22



15 cm - 6"

06.31.15



15 cm - 6"

06.31.25



12,5 cm - 5"

06.31.32

Semken

Semken



TREVALLi

Feine Pinzetten, anatomisch und chirurgisch
Delicate Forceps, dressing and tissue
Pinzas finas, anatómicas y quirúrgicas
Pinces délicates, anatomiques et chirurgicales
Pinze delicate, anatomiche e chirurgiche



11 cm - 4 3/8"

06.34.51



13 cm - 5 1/8"

06.34.53



15 cm - 6"

06.34.55



18 cm - 7 1/8"

06.34.58



20 cm - 8"

06.34.60

"Select"



11 cm - 4 3/8"

06.35.51



13 cm - 5 1/8"

06.35.53



15 cm - 6"

06.35.55



18 cm - 7 1/8"

06.35.58



20 cm - 8"

06.35.60

"Select"



TREVALLi

Feine Pinzetten, anatomisch und chirurgisch
Delicate Forceps, dressing and tissue
Pinzas finas, anatómicas y quirúrgicas
Pinces délicates, anatomiques et chirurgicales
Pinze delicate, anatomiche e chirurgiche



15 cm - 6"

06.40.15

McIndoe



15 cm - 6"

06.40.85

Gillies



20 cm - 8"

06.45.20



13 cm - 5 1/8"

06.44.13

15 cm - 6"

06.44.15

17 cm - 6 3/4"

06.44.17

20 cm - 8"

06.44.20

Schwedisches Modell
 Swedish pattern
 Modelo sueco
 Modèle suédois
 Modello svedese



TREVALLi

Anatomische und chirurgische Pinzetten
Dressing and Tissue Forceps
Pinzas anatómicas y quirúrgicas
Pinces anatomiques et chirurgicales
Pinze anatomiche e chirurgiche



18 cm - 7 1/8"

06.46.18



21 cm - 8 1/4"

06.46.20



25 cm - 10"

06.46.25



18 cm - 7 1/8"

06.48.18



21 cm - 8 1/4"

06.48.20



25 cm - 10"

06.48.25

Potts-Smith

Potts-Smith



18 cm - 7 1/8"

06.60.90



18 cm - 7 1/8"

06.60.91



18 cm - 7 1/8"

06.60.92

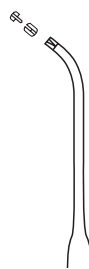

18 cm - 7 1/8"

06.60.93

Gerald



TREVALLi

Atraumatische Gefäßpinzetten
Atraumatic Vascular Forceps
Pinzas vasculares atraumáticas
Pinces vasculaires atraumatiques
Pinze vascolari atraumatiche

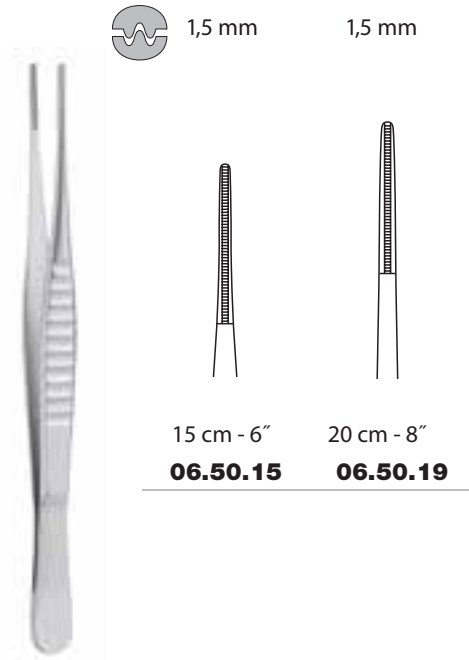

15 cm - 6"
06.50.15

1,5 mm
1,5 mm
20 cm - 8"
06.50.19

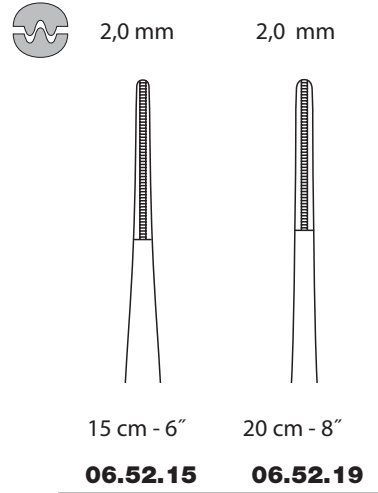

15 cm - 6"
06.52.15

2,0 mm
2,0 mm
20 cm - 8"
06.52.19

DeBakey "AT"

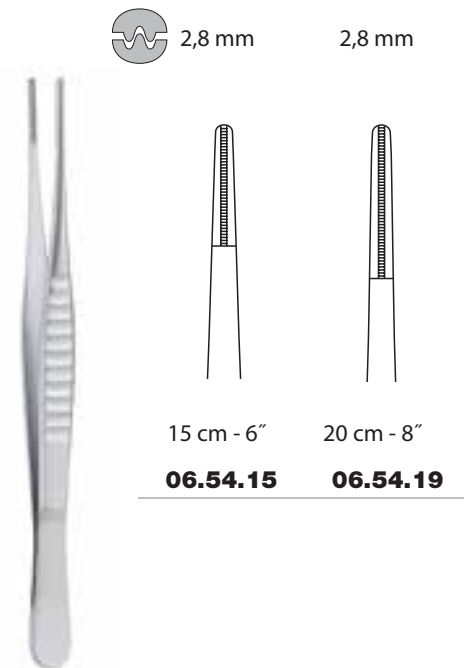

15 cm - 6"
06.54.15

2,8 mm
2,8 mm
20 cm - 8"
06.54.19

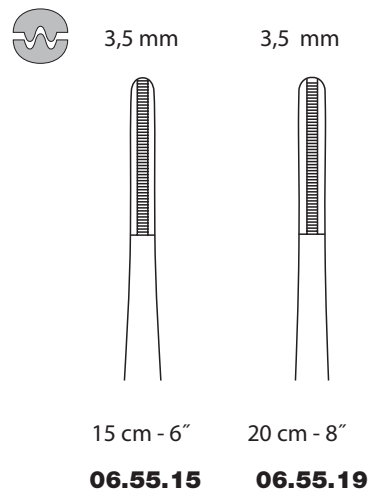

15 cm - 6"
06.55.15

3,5 mm
3,5 mm
20 cm - 8"
06.55.19

DeBakey "AT"



TREVALLi

Atraumatische Gefäßpinzetten
Atraumatic Vascular Forceps
Pinzas vasculares atraumáticas
Pinces vasculaires atraumatiques
Pinze vascolari atraumatiche



DeBakey "AT"

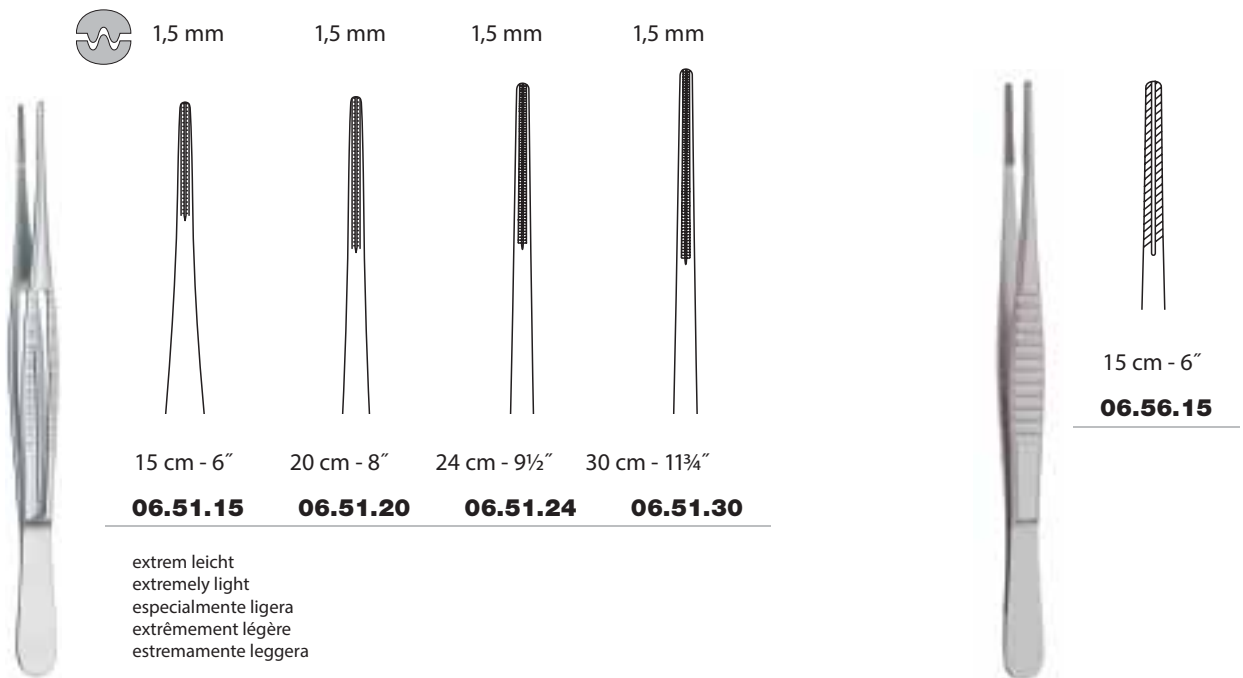

DeBakey "AT"

"AT"

extrem leicht
extremely light
especialmente ligera
extrêmement légère
estremamente leggera



TREVALLI



Titanium

Atraumatische Gefäßpinzetten
Atraumatic Vascular Forceps
Pinzas vasculares atraumáticas
Pinces vasculaires atraumatiques
Pinze vascolari atraumatiche



1,0 mm

1,0 mm



15 cm - 6"

06.70.15

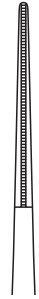

20 cm - 8"

06.70.20



1,5 mm

1,5 mm



15 cm - 6"

06.72.15

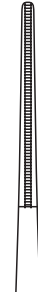

20 cm - 8"

06.72.20



DeBakey "AT"



2,0 mm

2,0 mm



15 cm - 6"

06.74.15

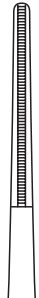

20 cm - 8"

06.74.20



2,8 mm

2,8 mm

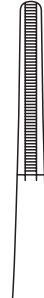

15 cm - 6"

06.76.15

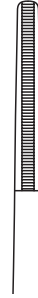

20 cm - 8"

06.76.20



DeBakey "AT"



TREVALLi



Atraumatiche Pinzette
Atraumatic Forceps
Pinzas atraumáticas
Pinces atraumatiques
Pinze atraumatiche



1,2 mm

1,2 mm

1,2 mm

1,2 mm

1,2 mm

1,2 mm

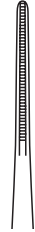
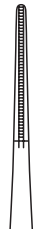

15 cm - 6"

18 cm - 7 1/8"

21 cm - 8 1/4"

15 cm - 6"

18 cm - 7 1/8"

21 cm - 8 1/4"

06.90.15

06.90.18

06.90.21

06.91.15

06.91.18

06.91.21

DeBakey "AT"



1,8 mm

1,8 mm

1,8 mm

1,8 mm

1,8 mm

1,8 mm

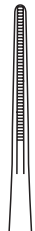
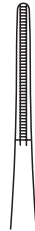

15 cm - 6"

18 cm - 7 1/8"

21 cm - 8 1/4"

15 cm - 6"

18 cm - 7 1/8"

21 cm - 8 1/4"

06.92.15

06.92.18

06.92.21

06.93.15

06.93.18

06.93.21

DeBakey "AT"



TREVALLi

Bajonettpinzetten
Bayonet Forceps
Pinzas en forma bayoneta
Pinces en forme baïonnette
Pinze a forma di baionetta



Lucae



14 cm - 5½"

07.30.14



14 cm - 5½"

07.30.74



Lucae



14 cm - 5½"

07.31.14



Gruenwald



16 cm - 6¼"

07.30.16



19,5 cm - 7¾"

07.30.19



Gruenwald



16 cm - 6¼"

07.31.16



19,5 cm - 7¾"

07.31.19



TREVALLi

**Pinzetten kniegebogen
Angular Forceps
Pinzas acodadas
Pinces coudées
Pinze angolate**

für Kinder
for children
para niños
pour enfants
per bambini

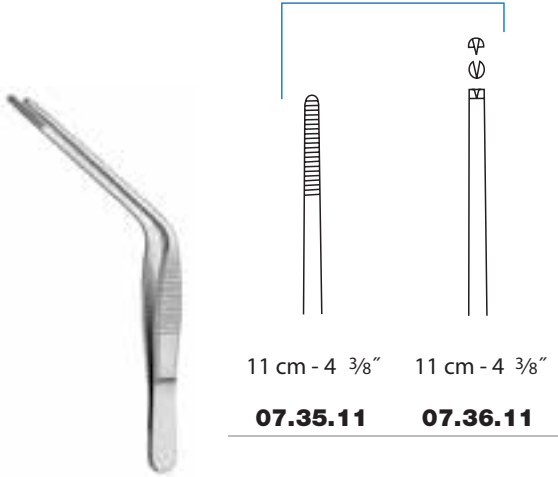

11 cm - 4 3/8" 11 cm - 4 3/8"
07.35.11 07.36.11

Troeltsch (Wilde)

für Erwachsene
for adults
para adultos
pour adultes
per adulti

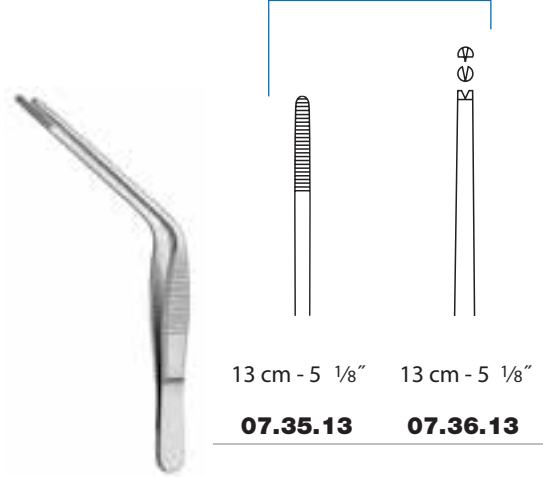

13 cm - 5 1/8" 13 cm - 5 1/8"
07.35.13 07.36.13

Troeltsch (Wilde)

für Säuglinge
for babies
para lactantes
pour nourrissons
per neonati

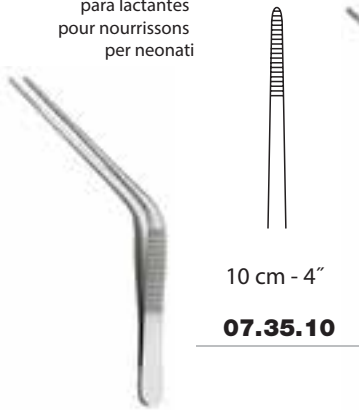

10 cm - 4"
07.35.10

Troeltsch (Wilde)



Troeltsch

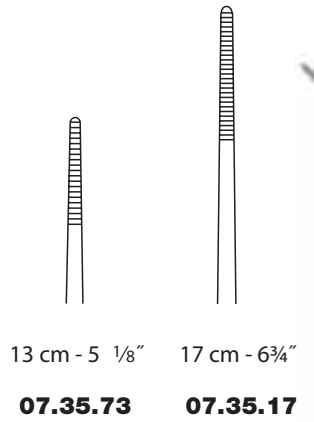

13 cm - 5 1/8" 17 cm - 6 3/4"
07.35.73 07.35.17

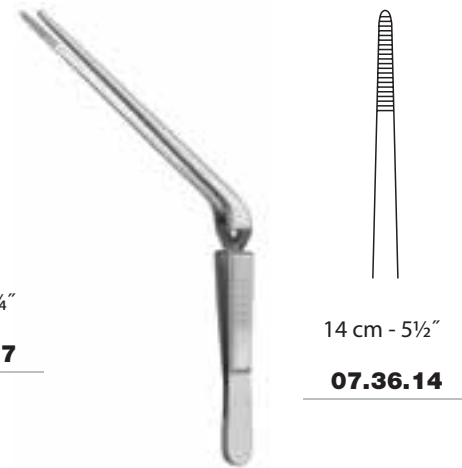

14 cm - 5 1/2"
07.36.14

Troeltsch



TREVALLi

Mikro Pinzetten
Micro Forceps
Micro pinzas
Micro pinces
Micro pinze

no. 3

no. 4

no. 5

no. 7

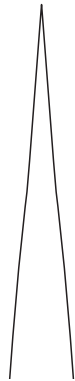

11,5 cm - 4½" 11,5 cm - 4½" 11,5 cm - 4½" 11,5 cm - 4½"

07.60.03

07.60.04

07.60.05

07.60.07

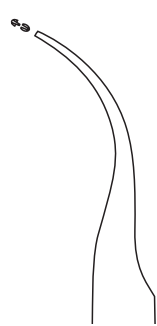

11 cm - 4 ¾" 11 cm - 4 ¾"

07.60.10

07.60.11

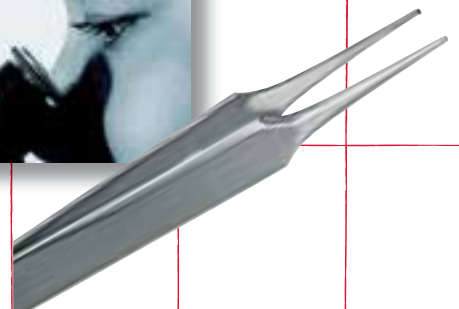

Weitere Juwelierpinzetten finden Sie in unserem Hauptkatalog
For further jeweler's forceps see our main catalogue
Más pinzas para joyero/relojero se encuentra en nuestro catálogo general
Vous trouverez d'autres pinces pour joaillier/horloger dans notre catalogue général
Ulteriori pinze per gioielliere/orologiaio si trovano nel nostro catalogo generale



TREVALLI

Mikro Pinzetten
Micro Forceps
Micro pinzas
Micro pincas
Micro pinze

0,2 mm 0,3 mm

10,5 cm - 4 1/8" 10,5 cm - 4 1/8"

07.61.05 07.61.06

micro 2000

0,2 mm 0,3 mm

11,5 cm - 4 1/2" 11,5 cm - 4 1/2"

07.61.07 07.61.08

micro 2000

0,2 mm 0,3 mm 0,3 mm

10,5 cm - 4 1/8" 10,5 cm - 4 1/8" 11,5 cm - 4 1/2"

07.61.25 07.61.26 07.61.28

micro 2000

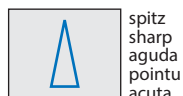

spitz
sharp
aguda
pointu
acuta



stumpf
blunt
roma
mousse
smussa



TREVALLi

Mikro Pinzetten
Micro Forceps
Micro pinzas
Micro pinces
Micro pinze



0,2 mm



0,2 mm



0,3 mm



0,3 mm



15 cm - 6"

15 cm - 6"

15 cm - 6"

15 cm - 6"

07.64.63

07.64.73

07.64.64

07.64.74

Leichtmetall-Instrumente mit blau eloxierten Rundgriffen
Light-weight instruments with blue anodized round handles
Instrumentos de metal ligero con mangos redondos anodizados azul
Instruments en métal léger, avec manches ronds anodisés en bleu
Strumenti di metallo leggero con manici rotondi, anodizzati blu

micro 2000



0,3 mm



0,3 mm



0,4 mm



0,4 mm



18 cm - 7 1/8"

18 cm - 7 1/8"

18 cm - 7 1/8"

18 cm - 7 1/8"

07.64.83

07.64.93

07.64.84

07.64.94

micro 2000



spitz
sharp
aguda
pointu
acuta



stumpf
blunt
roma
mousse
smussa



TREVALLi

Mikro Pinzetten, Gewebefasspinzetten
Micro Forceps, Tissue Grasping Forceps
Micro pinzas, Pinzas para agarrar tejidos
Micro pinces, Pinces pour saisir le tissu
Micro pinze, Pinze per afferrare tessuti



Rundgriff
Round handle
Mango redondo
Manche rond
Manico rotondo



0,4 mm



15 cm - 6"

07.74.15

0,4 mm



15 cm - 6"

07.75.15

0,8 mm



15 cm - 6"

07.76.15

0,8 mm



15 cm - 6"

07.77.15

18 cm - 7 1/8"

07.74.18

18 cm - 7 1/8"

07.75.18

18 cm - 7 1/8"

07.76.18

18 cm - 7 1/8"

07.77.18

21 cm - 8 1/4"

07.74.21

21 cm - 8 1/4"

07.75.21

21 cm - 8 1/4"

07.76.21

21 cm - 8 1/4"

07.77.21



Graefe



11 cm - 4 3/8"

07.00.10



11 cm - 4 3/8"

07.00.30



Graefe



11 cm - 4 3/8"

07.01.10



11 cm - 4 3/8"

07.01.30



TREVALLi

**Nadelhalter
Needle Holders
Porta-agujas
Porte-aiguilles
Portaghi**

"HM"

Nadelhalter mit Hartmetalleinlagen
Needle holders with tungsten carbide inserts
Porta-agujas con bocas revestidas de plaquitas de carburo de tungsteno
Porte-aiguilles avec mors en carbure de tungstène
Portaghi con morsi rivestiti di placchette di carburo di tungsteno

0,5 mm

für Nadeln und Nahtmaterial bis Stärke 4-0
for needles and sutures up to size 4-0
para agujas y material de sutura hasta el espesor de 4-0
pour aiguilles et matériel à suture jusqu'à une épaisseur de 4-0
per aghi e materiale per sutura fino ad uno spessore di 4-0

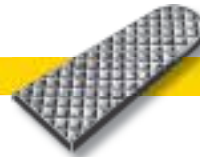

N

normal
regular
normal
normale
normale

0,4 mm

für feine Nadeln und Nahtmaterial Stärke 5-0 und 6-0
for delicate needles and sutures sizes 5-0 and 6-0
para agujas finas y material de sutura para espesores 5-0 y 6-0
pour aiguilles fines et matériel à suture d'une épaisseur de 5-0 et 6-0
per aghi fini e materiale per sutura fino ad uno spessore 5-0 e 6-0

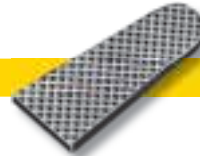

F

fein
fine
fino
fine
fine

0,3 mm

für Mikro-Nadeln und Nahtmaterial bis Stärke 10-0
for micro-needles and sutures up to size 10-0
para micro-agujas y material de sutura hasta el espesor de 10-0
pour micro-aiguilles et matériel à suture jusqu'à une épaisseur de 10-0
per micro-aghi e materiale per sutura fino ad uno spessore di 10-0

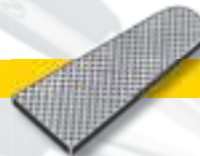

EF

extra-fein
extra-fine
extra-fino
extra-fine
extra-fine

für feine Nadeln und Nahtmaterial Stärke 7-0 bis 10-0
for delicate needles and sutures from sizes 7-0 to 10-0
para agujas finas y material de sutura para espesores 7-0 y 10-0
pour aiguilles fines et matériel à suture d'une épaisseur 7-0 à 10-0
per aghi fini e materiale per sutura di uno spessore di 7-0 fino a 10-0

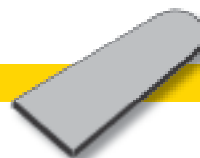

■

glatt
smooth
liso
lisse
liscia



TREVALLi

Nadelhalter
Needle Holders
Porta-agujas
Porte-aiguilles
Portaghi

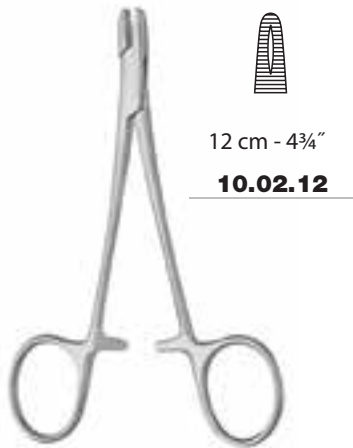

12 cm - 4¾"

10.02.12

Derf

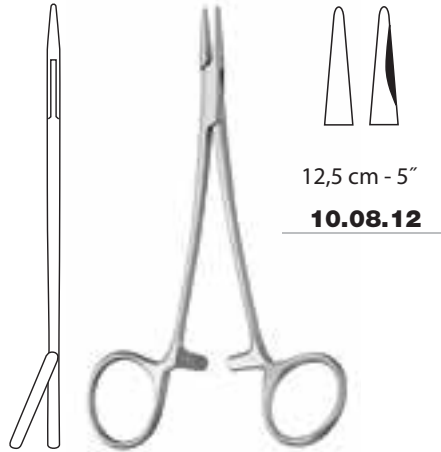

12,5 cm - 5"

10.08.12

Neivert



12,5 cm - 5"

10.08.62

Neivert "HM"

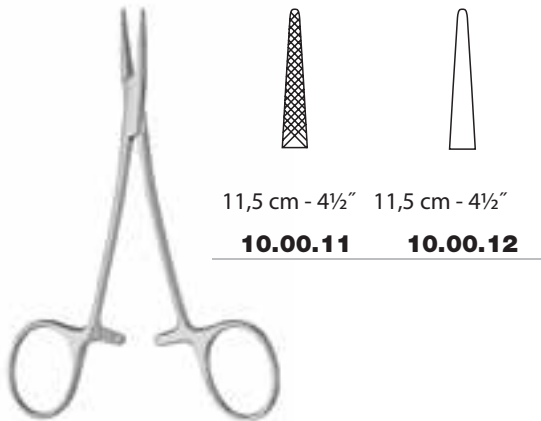

11,5 cm - 4½" 11,5 cm - 4½"

10.00.11

10.00.12

Medicon-Halsted



11,5 cm - 4½"

10.00.62

Medicon-Halsted "HM"

"HM"
Hartmetall
Tungsten carbide
Carburo de tungsteno
Carbure de tungstène
Carburo di tungsteno

glatt
smooth
liso
lisse
liscia
7-0 to 10-0



TREVALLi

**Nadelhalter
Needle Holders
Porta-agujas
Porte-aiguilles
Portaghi**

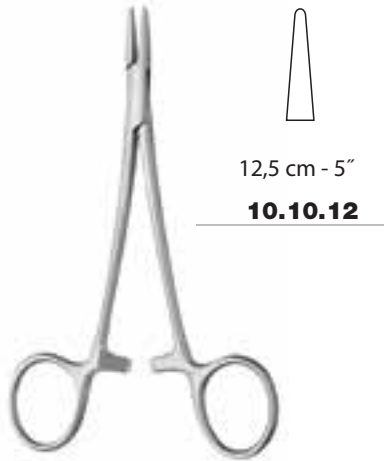

12,5 cm - 5"

10.10.12

Webster



12,5 cm - 5"

10.10.62

Webster "HM"

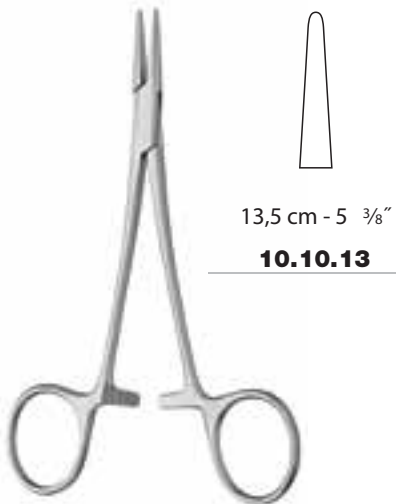

13,5 cm - 5 3/8"

10.10.13

Halsey

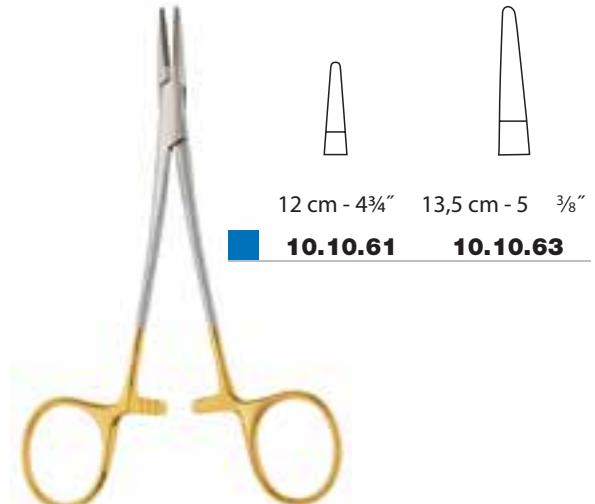

12 cm - 4 3/4"

10.10.61

13,5 cm - 5 3/8"

10.10.63

Halsey "HM"

"HM"
Hartmetall
Tungsten carbide
Carburo de tungsteno
Carbure de tungstène
Carburo di tungsteno

7-0 to 10-0
glatt
smooth
liso
lisse
liscia



TREVALLI

**Nadelhalter
Needle Holders
Porta-agujas
Porte-aiguilles
Portaghi**

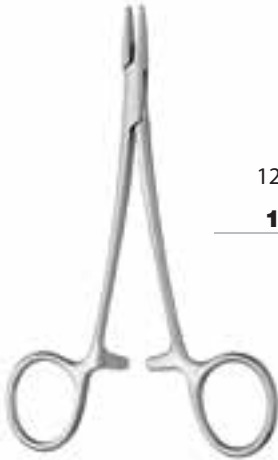

12,5 cm - 5"
10.12.12

Wright (Derf)

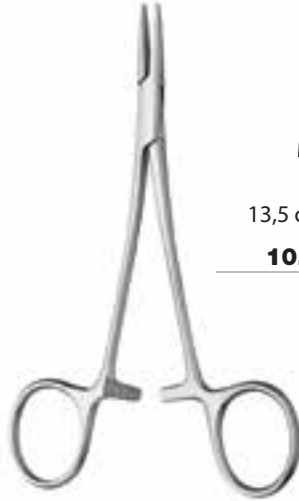

13,5 cm - 5 3/8"
10.12.13

Halsey



14 cm - 5 1/2"
10.14.14

Baumgartner



12,5 cm - 5"
F 10.12.62

Wright (Derf) "HM"



13,5 cm - 5 3/8"
F 10.12.63

Halsey "HM"



14 cm - 5 1/2"
N 10.14.64

Baumgartner "HM"

"HM"
Hartmetall
Tungsten carbide
Carburo de tungsteno
Carbure de tungstène
Carburo di tungsteno



F
5-0 and 6-0
fein
fine
fino
fine
fine

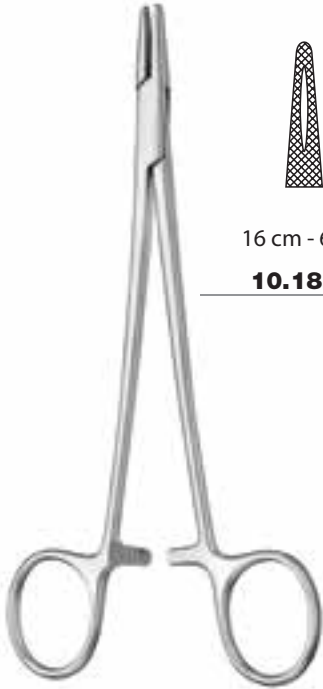

TREVALLi

**Nadelhalter
Needle Holders
Porta-agujas
Porte-aiguilles
Portaghi**



		
16 cm - 6 1/4"	18 cm - 7 1/8"	20 cm - 8"
10.18.15	10.18.18	10.18.20



Mayo-Hegar



15 cm - 6"
10.20.14

Baby-Crile-Wood



		
16 cm - 6 1/4"	18 cm - 7 1/8"	20 cm - 8"
N 10.18.65	10.18.68	10.18.70

Mayo-Hegar "HM"



15 cm - 6"
F 10.20.64

Baby-Crile-Wood "HM"

"HM"
Hartmetall
Tungsten carbide
Carburo de tungsteno
Carbure de tungstène
Carburo di tungsteno

N
4-0
normal
regular
normal
normale
normale



TREVALLi

**Nadelhalter
Needle Holders
Porta-agujas
Porte-aiguilles
Portaghi**



Crile-Wood



15 cm - 6" **10.20.15** 18 cm - 7 1/8" **10.20.18** 20 cm - 8" **10.20.20**



Sarot



18 cm - 7 1/8" **10.22.18**



**Crile-Wood "HM"
(DeBakey "HM")**

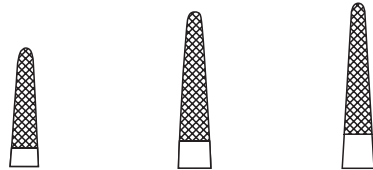

15 cm - 6" **F 10.20.65** 18 cm - 7 1/8" **10.20.68** 20 cm - 8" **10.20.70**



Sarot "HM"



18 cm - 7 1/8" **F 10.22.68**

"HM"
Hartmetall
Tungsten carbide
Carburo de tungsteno
Carbure de tungstène
Carburo di tungsteno

F
5-0 and 6-0
fein
fine
fino
fine
fine



TREVALLI

Nadelhalter
Needle Holders
Porta-agujas
Porte-aiguilles
Portaghi



micro-slim "HM"



15 cm - 6"

F 10.24.65



18 cm - 7 1/8"

10.24.68



20 cm - 8"

F 10.24.70



23 cm - 9"

10.24.73



Ryder (French Eye) "HM"



13 cm - 5 1/8"

N 10.26.63



15 cm - 6"

10.26.65

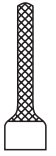

18 cm - 7 1/8"

10.26.68



20 cm - 8"

N 10.26.70



23 cm - 9"

10.26.73



Mini-Ryder "HM"



13 cm - 5 1/8"

EF 10.28.63



15 cm - 6"

10.28.65



18 cm - 7 1/8"

10.28.68



20 cm - 8"

EF 10.28.70



23 cm - 9"

10.28.73

"HM"

Hartmetall
Tungsten carbide
Carburo de tungsteno
Carbure de tungstène
Carburo di tungsteno

N

4-0

normal
regular
normal
normale
normale

EF

10-0

extra-fein
extra-fine
extra-fine
extra-fine
extra-fine



TREVALLi

Nadelhalter
Needle Holders
Porta-agujas
Porte-aiguilles
Portaghi

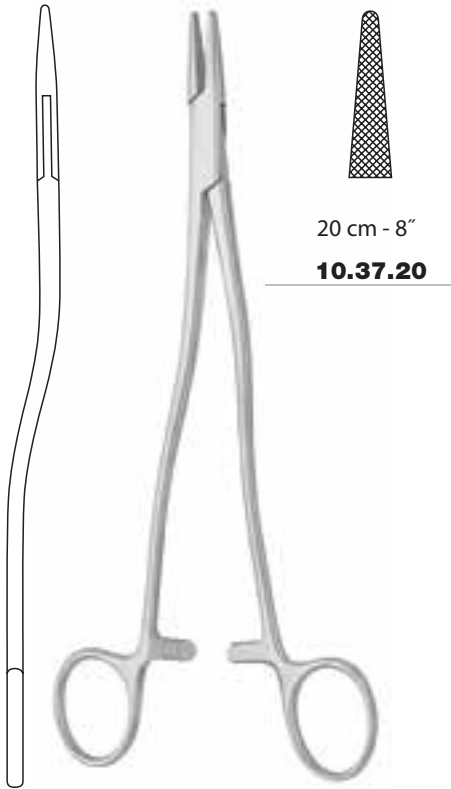

20 cm - 8"
10.37.20

Thomson-Walker (Bozemann)



20 cm - 8"
N 10.37.70

Bozemann (Wertheim) "HM"



17 cm - 6 3/4"
10.39.17

Senning

Senning "HM"

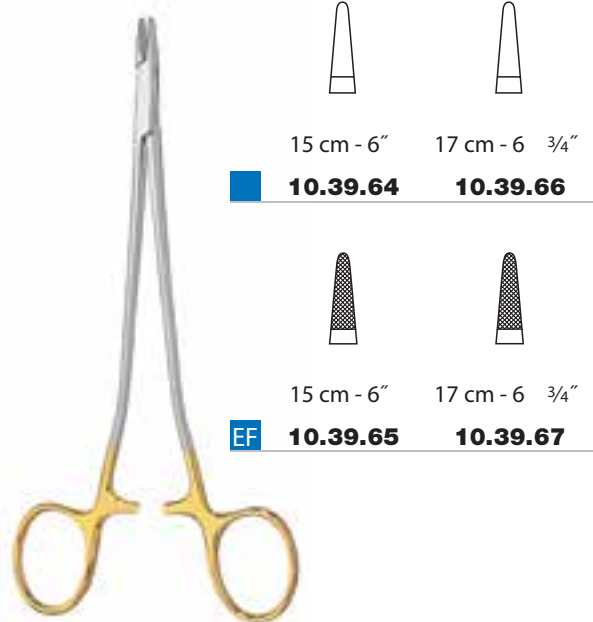

15 cm - 6" 17 cm - 6 3/4"
10.39.64 **10.39.66**

15 cm - 6" 17 cm - 6 3/4"
EF 10.39.65 **10.39.67**

"HM"
Hartmetall
Tungsten carbide
Carburo de tungsteno
Carbure de tungstène
Carburo di tungsteno

N
4-0
normal
regular
normal
normale
normale

EF
10-0
extra-fein
extra-fine
extra-fino
extra-fine



TREVALLi

Nadelhalter
Needle Holders
Porta-agujas
Porte-aiguilles
Portaghi

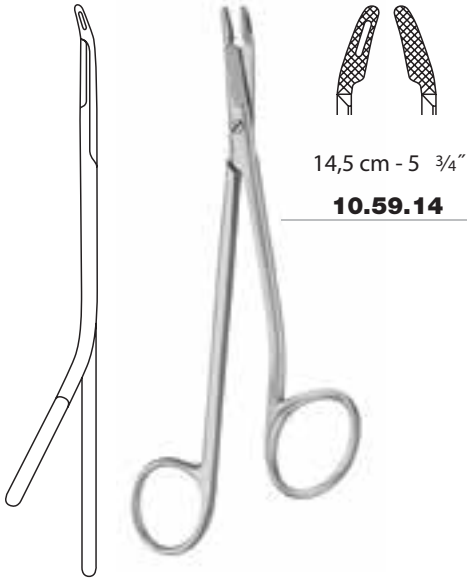

14,5 cm - 5 3/4"

10.59.14

Gillies-slim



14,5 cm - 5 3/4"

F 10.59.64

Gillies-slim "HM"

Nadelhalter mit Schere
Needle holders with scissors
Porta-agujas con tijera
Porte-aiguilles avec ciseaux
Portaghi con forbice

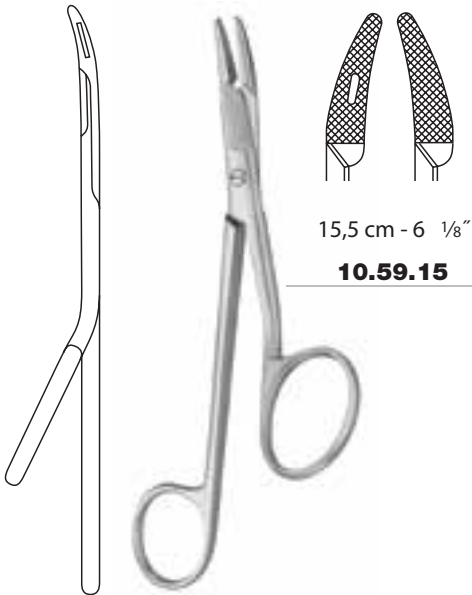

15,5 cm - 6 1/8"

10.59.15

Gillies



15,5 cm - 6 1/8"

F 10.59.65

Gillies "HM"

"HM"
Hartmetall
Tungsten carbide
Carburo de tungsteno
Carbure de tungstène
Carburo di tungsteno

glatt
smooth
liso
lisse
liscia

F
5-0 and 6-0
fein
fine
fino
fine
fine



TREVALLI

Nadelhalter
Needle Holders
Porta-agujas
Porte-aiguilles
Portaghi



Olsen-Hegar



14 cm - 5 1/2"

10.60.14



17 cm - 6 3/4"

10.60.17



19 cm - 7 1/2"

10.60.19



Olsen-Hegar "HM"



14 cm - 5 1/2"

F 10.60.64



17 cm - 6 3/4"

10.60.67



19 cm - 7 1/2"

10.60.69

"HM"
Hartmetall
Tungsten carbide
Carburo de tungsteno
Carbure de tungstène
Carburo di tungsteno

F
5-0 and 6-0
fein
fine
fino
fine
fine



TREVALLi

Nadelhalter
Needle Holders
Porta-agujas
Porte-aiguilles
Portaghi



14 cm - 5 1/2"

11.18.14



17 cm - 6 3/4"

11.18.17

Mathieu-Kocher



14 cm - 5 1/2"

N

11.18.64



17 cm - 6 3/4"

11.18.67

Mathieu-Kocher "HM"



14 cm - 5 1/2"

11.20.14



17 cm - 6 3/4"

11.20.17

Mathieu



14 cm - 5 1/2"

N

11.20.64



17 cm - 6 3/4"

11.20.67

Mathieu "HM"

"HM"
Hartmetall
Tungsten carbide
Carburo de tungsteno
Carbure de tungstène
Carburo di tungsteno

N
4-0
normal
regular
normal
normale
normale



TREVALLi

**Nadelhalter
Needle Holders
Porta-agujas
Porte-aiguilles
Portaghi**



14 cm - 5½"

14 cm - 5½"

11.62.14

11.62.15

17 cm - 6¾"

17 cm - 6¾"

11.62.17

11.62.18

mit Sperre
with catch
con cremallera
avec crémaillère
con cremagliera

Castroviejo



14 cm - 5½"

17 cm - 6¾"

11.62.64

11.62.67



14 cm - 5½"

17 cm - 6¾"

EF

11.62.84

11.62.87

mit Sperre
with catch
con cremallera
avec crémaillère
con cremagliera

Castroviejo "HM"



14,5 cm - 5¾"

14,5 cm - 5¾"

11.70.24

11.70.25

mit Sperre
with catch
con cremallera
avec crémaillère
con cremagliera

Castroviejo-micro



14,5 cm - 5¾"

14,5 cm - 5¾"

11.70.22

11.70.23

Castroviejo-micro

"HM"

Hartmetall
Tungsten carbide
Carburo de tungsteno
Carbure de tungstène
Carburo di tungsteno

7-0 to 10-0

glatt
smooth
liso
lisse
liscia

EF

10-0

extra-fein
extra-fine
extra-fino
extra-fine



TREVALLi

Mikro Nadelhalter
Micro Needle Holders
Micro porta-agujas
Micro porte-aiguilles
Micro portaghi



16 cm - 6 1/4"

16 cm - 6 1/4"

12.15.50

12.15.51

Yasargil



15 cm - 6"

15 cm - 6"

12.15.30

12.15.31

micro 2000



15 cm - 6"

15 cm - 6"

12.15.32

12.15.33

mit Sperre
with catch
con cremallera
avec crémaillère
con cremagliera

micro 2000

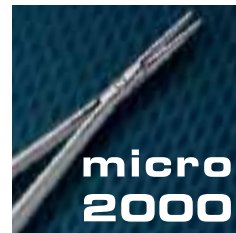



TREVALLi

Mikro Nadelhalter
Micro Needle Holders
Micro porta-agujas
Micro porte-aiguilles
Micro portaghi



15 cm - 6"

12.15.70



15 cm - 6"

12.15.71



18 cm - 7 1/8"

12.18.70



18 cm - 7 1/8"

12.18.71

Leichtmetall-Instrumente mit blau eloxierten Rundgriffen
Light-weight instruments with blue anodized round handles
Instrumentos de metal ligero con mangos redondos anodizados azul
Instruments en métal léger avec manches ronds anodisés en bleu
Strumenti di metallo leggero con manici rotondi anodizzati blu

micro 2000



15 cm - 6"

12.15.72



15 cm - 6"

12.15.73



18 cm - 7 1/8"

12.18.72



18 cm - 7 1/8"

12.18.73

 **12.18.74**  **12.18.75**

mit Sperre
with catch
con cremallera
avec crémaillère
con cremagliera

micro 2000



mit Diamantbeschichtung
with diamond dust coating
con recubrimiento de diamante
avec couche diamantée
con rivestimento di diamante



TREVALLi



Mikro Nadelhalter
Micro Needle Holders
Micro porta-agujas
Micro porte-aiguilles
Micro portaghi



15 cm - 6"

15 cm - 6"

18 cm - 7 1/8"

18 cm - 7 1/8"

21 cm - 8 1/4"

21 cm - 8 1/4"

12.16.75

12.16.77

12.18.85

12.18.87

12.21.95

12.21.97

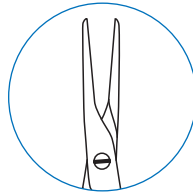

8 mm
Rundgriff
Round handle
Mango redondo
Manche rond
Manico rotondo



15 cm - 6"

15 cm - 6"

18 cm - 7 1/8"

18 cm - 7 1/8"

21 cm - 8 1/4"

21 cm - 8 1/4"

12.16.76

12.16.78

12.18.86

12.18.88

12.21.96

12.21.98

mit Sperre
with catch
con cremallera
avec crémaillère
con cremagliera

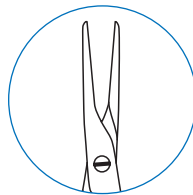

8 mm
Rundgriff
Round handle
Mango redondo
Manche rond
Manico rotondo



TREVALLi

Mikro Nadelhalter
Micro Needle Holders
Micro porta-agujas
Micro porte-aiguilles
Micro portaghi



Yasargil



16 cm - 6 1/4"
58.16.45



16 cm - 6 1/4"
58.16.48



18,5 cm - 7 1/4"
58.19.40



18,5 cm - 7 1/4"
58.19.45



Yasargil



20 cm - 8"
59.20.40



20 cm - 8"
59.20.45



23 cm - 9"
59.23.42



23 cm - 9"
59.23.45



TREVALLi

Knopfsonden

Probes

Estiletos abotonados

Stylets boutonés

Specilli bottonuti

Ø 1,0 mm



14,5 cm - 5¾"

09.03.14

Ø 1,5 mm



09.04.10 | 10,5 cm - 4 1/8"

09.04.11 | 11,5 cm - 4½"

09.04.13 | 13,0 cm - 5 1/8"

09.04.14 | 14,5 cm - 5¾"

09.04.16 | 16,0 cm - 6¼"

09.04.18 | 18,0 cm - 7 1/8"

09.04.20 | 20,0 cm - 8"

09.04.25 | 25,0 cm - 10"

Ø 2,0 mm



09.05.10 | 10,5 cm - 4 1/8"

09.05.11 | 11,5 cm - 4½"

09.05.13 | 13,0 cm - 5 1/8"

09.05.14 | 14,5 cm - 5¾"

09.05.16 | 16,0 cm - 6¼"

09.05.18 | 18,0 cm - 7 1/8"

09.05.20 | 20,0 cm - 8"

09.05.25 | 25,0 cm - 10"

09.05.30 | 30,0 cm - 11¾"

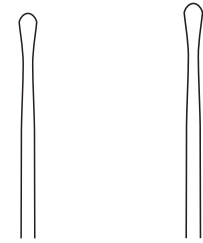

13 cm - 5 1/8"

14,5 cm - 5¾"

09.08.13

09.08.14

16 cm - 6¼"

20 cm - 8"

09.08.16

09.08.20



Myrtenblattsonden

Myrtle leaf probes

Estiletos con hoja de mirto

Stylets feuille de myrte

Specilli a foglia di mirto



TREVALLi

**Hohlsonden, Knopfsonden
Directors, Probes
Sondas acanaladas, Estiletos abotonados
Sondes cannelées, Stylets boutonnés
Specilli scanalati, Specilli bottonuti**



14 cm - 5½"
09.15.84



11,5 cm - 4 ⅛" 14,5 cm - 5¾"
09.15.11 09.15.14

16 cm - 6¼" 18 cm - 7 ⅛"
09.15.16 09.15.18

20 cm - 8"
09.15.20



18 cm - 7 ⅛"
72.25.01

aus Silber
Sterling Silber
de plata pura
en argent pur
in argento puro

Speichelgangsonde
Salivary duct probe
Sonda para canal de saliva
Sonde pour conduit salivaire
Sonda per canale salivale

Seiffert

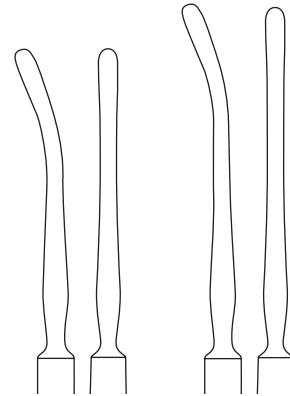

13 cm - 5 ⅛" 18 cm - 7 ⅛"
09.17.13 09.17.18

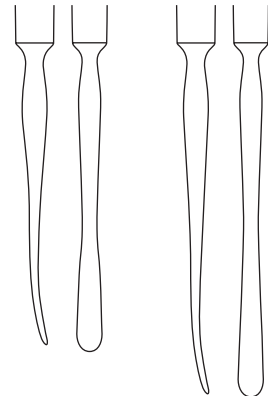

Watson-Cheyne



TREVALLi

Tränenkanalsonden
Lacrimal Probes
Sondas exploradoras para canal lagrimal
Sondes exploratrices pour le canal lacrymal
Sonde esploratrici per canale lacrimale



# 4/0 - 3/0	# 00 - 0	# 1 - 2
60.34.00	60.34.01	60.34.02
# 3 - 4	# 5 - 6	# 7 - 8
60.34.04	60.34.06	60.34.08
# 4/0 - 3/0	# 00 - 0	# 1 - 2
60.34.10	60.34.11	60.34.12
# 3 - 4	# 5 - 6	# 7 - 8
60.34.14	60.34.16	60.34.18

aus Neusilber
 Nickel silver
 de plata alemana
 en maillechort
 in argentone

aus Silber
 Sterling silver
 de plata pura
 en argent pur
 in argento puro

Bowman

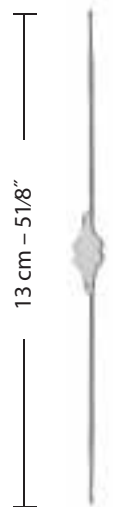

# 00 - 0	# 1 - 2	# 3 - 4
60.34.21	60.34.22	60.34.24
# 5 - 6	# 7 - 8	
60.34.26	60.34.28	
# 00 - 0	# 1 - 2	# 3 - 4
60.34.31	60.34.32	60.34.34
# 5 - 6	# 7 - 8	
60.34.36	60.34.38	

aus Neusilber
 Nickel silver
 de plata alemana
 en maillechort
 in argentone

aus Silber
 Sterling silver
 de plata pura
 en argent pur
 in argento puro

Bowman (Williams)

Größenskala für Sonden
 Size scale for probes
 Escala comparativa para sondas
 Echelle comparative pour sondes
 Scala comparativa per sonde

fig.	0000	000	00	0	1	2	3	4	5	6	7	8
Ø mm	0.6	0.7	0.8	0.9	1.0	1.1	1.2	1.3	1.4	1.5	1.6	1.7



TREVALLi

**Watteträger
Cotton Carriers
Porta- algodones
Porte-cotons
Portacotone**

Ø 1,0 mm



09.20.12 | 12 cm - 4¾"

09.20.14 | 14 cm - 5½"

09.20.16 | 16 cm - 6¼"

spiralförmig
spiral threads
estriás espirales
striure en spirale
striatura a spirale

Frohn

Ø 1,0 mm



09.20.62 | 12 cm - 4¾"

09.20.64 | 14 cm - 5½"

09.20.66 | 16 cm - 6¼"

Frohn

Ø 1,2 mm



09.21.12 | 12 cm - 4¾"

09.21.14 | 14 cm - 5½"

09.21.15 | 15 cm - 6"

09.21.16 | 16 cm - 6¼"

09.21.18 | 18 cm - 7 ⅛"

kreuzgerieft
cross threads
estriás cruzadas
striure croisée
striatura incrociata

Lathbury (Farrell)

Ø 1,2 mm



09.21.62 | 12 cm - 4¾"

09.21.64 | 14 cm - 5½"

09.21.65 | 15 cm - 6"

09.21.66 | 16 cm - 6¼"

09.21.68 | 18 cm - 7 ⅛"

Lathbury (Farrell)



TREVALLi

**Watteträger
Cotton Carriers
Porta-algodones
Porte-cotons
Portacotone**

Ø 1,5 mm

09.22.12	12 cm - 4¾"
09.22.14	14 cm - 5½"
09.22.16	16 cm - 6¼"
09.22.18	18 cm - 7 ⅛"

Ø 2,0 mm

09.25.15	15 cm - 6"
09.25.18	18 cm - 7 ⅛"

Andrews

Ø 1,3 mm

16 cm - 6¼"

09.27.16

Uckermann

Ø 1,2 mm

09.21.72	12 cm - 4¾"
09.21.74	14 cm - 5½"
09.21.76	16 cm - 6¼"

Ø 1,5 mm

18 cm - 7 ⅛"

09.27.18

Jobson-Horne



TREVALLi

**Punktionskanülen, Trokare
Puncture Cannulas, Trocars
Cánulas para punción, Trocares
Canules à ponction, Trocarts
Cannule per puntura, Trequarti**

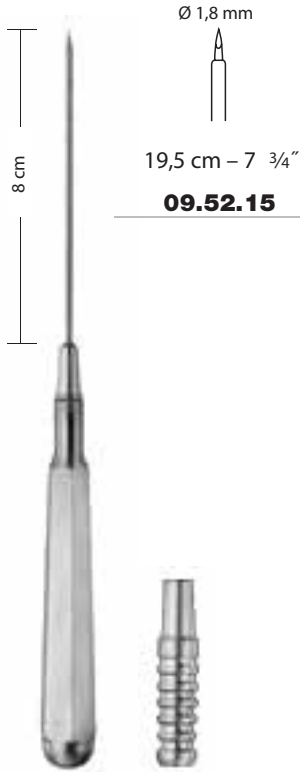

Lichtwitz

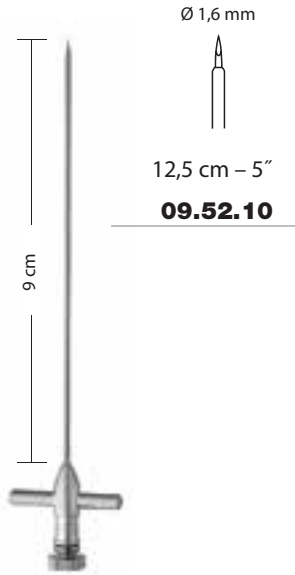

Lichtwitz



Coakley



Ø 0,8 mm
09.74.91

♀



Pierce

16 cm – 6 ¼"
Ø 3 mm
09.52.43

16 cm – 6 ¼"
Ø 4 mm
09.52.44

16 cm – 6 ¼"
Ø 5 mm
09.52.45



TREVALLi

**Punktionskanülen, Trokare
Puncture Cannulas, Trocars
Cánulas para punción, Trocares
Canules à ponction, Trocarts
Cannule per puntura, Trequarti**

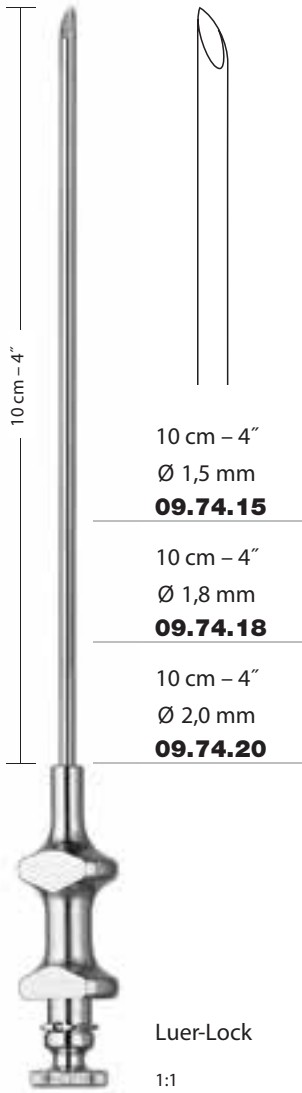

Lichtwitz

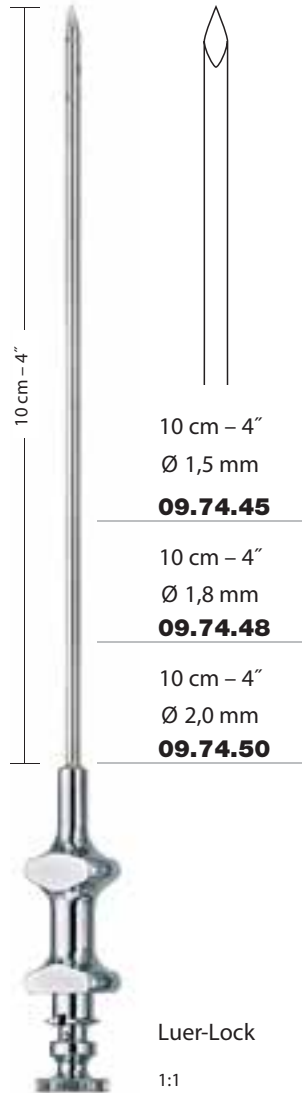

**Lichtwitz-
Eicken**

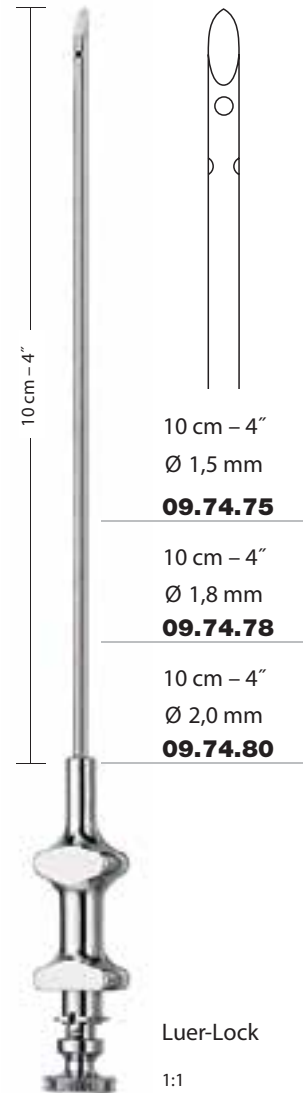

Vogel



TREVALLi

**Spritzen
Syringes
Jeringas
Seringues
Siringhe**



Luer-Lock

1 ml	2 ml	5 ml
09.78.31	09.78.32	09.78.33

10 ml	20 ml	50 ml
09.78.34	09.78.35	09.78.37

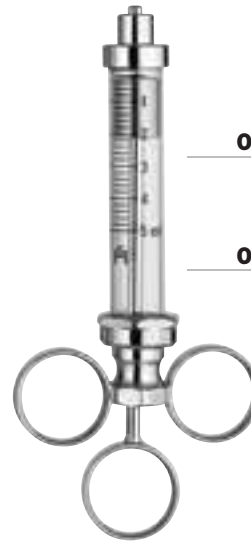

Luer-Lock

2 ml	5 ml
09.78.52	09.78.53

10 ml	20 ml
09.78.54	09.78.55

Ersatzzylinder
Spare barrels
Cilindros de repuesto
Cylindres de rechange
Cilindri di ricambio



Luer-Lock

1 ml	2 ml	5 ml
09.78.41	09.78.42	09.78.43

10 ml	20 ml	50 ml
09.78.44	09.78.45	09.78.47



TREVALLi

Verbindungsstücke, Hähne
Connecting Pieces, Stopcocks
Piezas de conexión, Llaves
Raccords, Robinets
Raccordi, Rubinetti



1:1

09.79.25

Luer-Lock
♂



1:1

09.79.27

Luer-Lock
♀



1:1

Katheteransätze, konisch
Catheter fittings, conical
Adaptadores para catéteres, cónicos
Adaptateurs pour cathéters, coniques
Adattatori per cateteri, conici

Ø 2 – 6 mm Ø 5 – 9 mm

09.79.32 **09.79.35**

Luer-Lock
♀



1:1

09.79.55

Luer-Lock

Durchflusshahn
Stopcock
Llave
Robinet
Rubinetto



1:1

09.79.65

Luer-Lock

Dreivegehahn
3-way stopcock
Llave de tres vías
Robinet à trois voies
Rubinetto a tre vie



TREVALLi

Sauginstrumente
Suction Instruments
Instrumentos de aspiración
Instrumenti d'aspirazione
Strumenti per aspirazione



13,5 cm - 5 3/8"

09.80.12

Charr. 12

Adson



13,5 cm - 5 3/8"

09.81.32

Charr. 12

Adson



13,5 cm - 5 3/8"

09.81.12

Charr. 12

Adson



12,5 cm - 5"

09.82.08

Charr. 8

Frazier



12,5 cm - 5"

09.82.28

Charr. 8

Frazier

12,5 cm - 5"
09.82.10

Charr. 10

12,5 cm - 5"
09.82.12

Charr. 12

12,5 cm - 5"
09.82.30

Charr. 10

12,5 cm - 5"
09.82.32

Charr. 12

Maßangaben = Nutzlänge (Kanüle)
Measurements = working length (cannula)
Medidas = longitud útil (cánula)
Mesures = longueur utile (canule)
Misura = lunghezza utile (cannula)



TREVALLi

Sauginstrumente
Suction Instruments
Instrumentos de aspiración
Instrument d'aspiration
Strumenti per aspirazione



Luer
♀

Frazier

12,5 cm - 5"	12,5 cm - 5"
09.83.06	09.83.08
Charr. 6	Charr. 8
12,5 cm - 5"	12,5 cm - 5"
09.83.10	09.83.12
Charr. 10	Charr. 12



Luer
♀

Frazier (Fergusson)

12,5 cm - 5"	12,5 cm - 5"
09.83.26	09.83.28
Charr. 6	Charr. 8
12,5 cm - 5"	12,5 cm - 5"
09.83.30	09.83.32
Charr. 10	Charr. 12
12,5 cm - 5"	
09.83.34	
Charr. 15	



Luer
♀

Frazier

18 cm - 7 1/8"	18 cm - 7 1/8"
09.83.56	09.83.58
Charr. 6	Charr. 8
18 cm - 7 1/8"	18 cm - 7 1/8"
09.83.60	09.83.62
Charr. 10	Charr. 12



Luer
♀

Frazier (Fergusson)

18 cm - 7 1/8"	18 cm - 7 1/8"
09.83.76	09.83.78
Charr. 6	Charr. 8
18 cm - 7 1/8"	18 cm - 7 1/8"
09.83.80	09.83.82
Charr. 10	Charr. 12

Maßangaben = Nutzlänge (Kanüle)
 Measurements = working length (cannula)
 Medidas = longitud útil (cánula)
 Mesures = longueur utile (canule)
 Misure = lunghezza utile (cannula)



TREVALLi

Sauginstrumente
Suction Instruments
Instrumentos de aspiración
Instruments d'aspiration
Strumenti per aspirazione



Plester

Luer
♀

13,5 cm - 5 3/8" 13,5 cm - 5 3/8"

09.84.05 **09.84.06**

Charr. 5 Charr. 6

13,5 cm - 5 3/8" 13,5 cm - 5 3/8"

09.84.08 **09.84.09**

Charr. 8 Charr. 9

Schaft isoliert
Insulated shaft
Vástago aislado
Tige isolée
Asta isolata



Fergusson

Luer
♀

12,5 cm - 5" 12,5 cm - 5"

09.83.47 **09.83.49**

Charr. 7 Charr. 9

12,5 cm - 5"

09.83.51

Charr. 11

Maßangaben = Nutzlänge (Kanüle)
Measurements = working length (cannula)
Medidas = longitud útil (cánula)
Mesures = longueur utile (canule)
Misura = lunghezza utile (cannula)



TREVALLi

Sauginstrumente
Suction Instruments
Instrumentos de aspiración
Instruments d'aspiration
Strumenti per aspirazione

28 cm - 11"

74.40.05

Charr. 5

28 cm - 11"

74.40.06

Charr. 6

28 cm - 11"

74.40.07

Charr. 7

28 cm - 11"

74.40.08

Charr. 8

28 cm - 11"

74.40.09

Charr. 9

28 cm - 11"

74.40.10

Charr. 10



09.85.12

Saugkopf allein
Suction tip only
Punta aspiradora sola
Tête aspiratrice seule
Testa aspiratrice sola



09.85.19

Schlaucholive allein
Tubing connector only
Oliva de tubos solo
Raccord olivaire seul
Raccordo olivare solo

für
for
para
pour
per 09.85.00



28 cm - 11"

09.85.00

Torrington

Luer
♀

Maßangaben = Nutzlänge (Kanüle)
Measurements = working length (cannula)
Medidas = longitud útil (cánula)
Mesures = longueur utile (canule)
Misure = lunghezza utile (cannula)

Yankauer



TREVALLI

Feine Wundhaken, doppelendig
Delicate Retractors, double-ended
Separadores finos, dobles
Ecarteurs fins, doubles
Divaricatori delicati, doppi

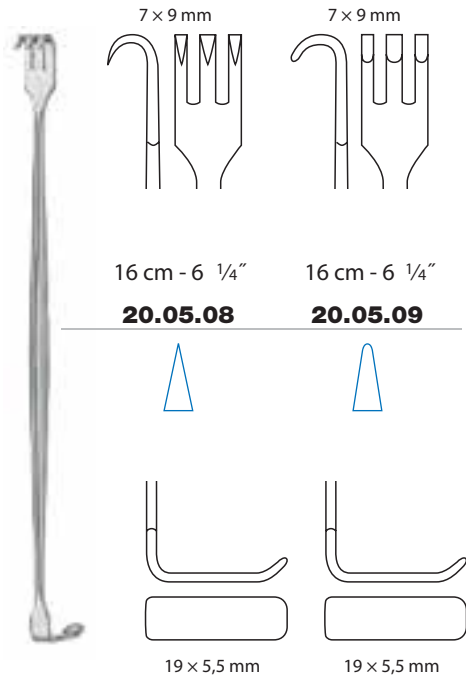

Senn-Miller

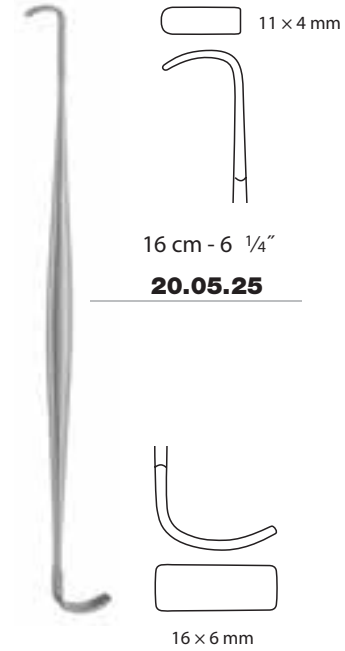

Ragnell

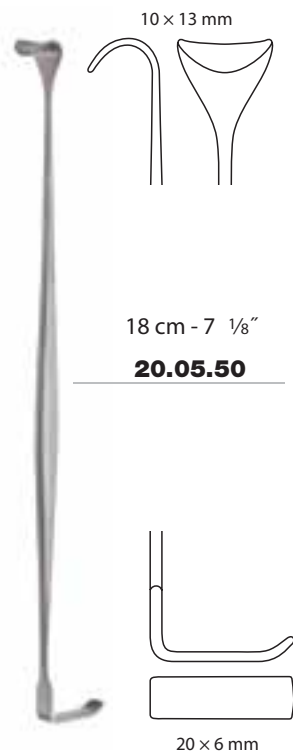

Cope



Lukens



Jackson



spitz
sharp
aguda
pointu
acuta



stumpf
blunt
roma
mousse
smussa



TREVALLI

**Feine Wundhaken
Delicate Retractors
Separadores finos
Ecarteurs fins
Divaricatori delicati**

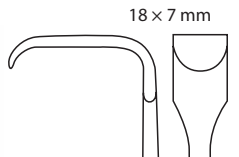

18 cm - 7 1/8"

20.10.01

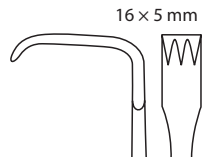

18 cm - 7 1/8"

20.10.02

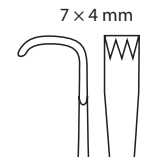

18 cm - 7 1/8"

20.10.03

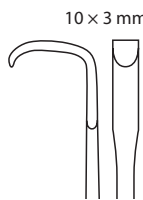

18 cm - 7 1/8"

20.10.04

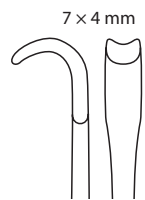

18 cm - 7 1/8"

20.10.05

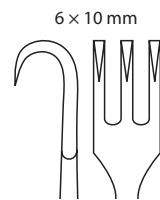

18 cm - 7 1/8"

20.10.06

Meyerding

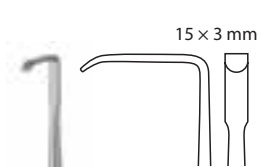

18 cm - 7 1/8"

20.12.18

Lanz

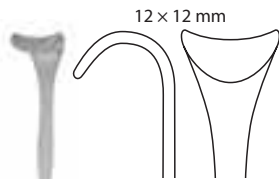

16 cm - 6 1/4"

20.09.50

Rose



12 x 10 mm



6 mm



Senn-Green



10 mm

14 cm - 5 1/2"

20.12.10

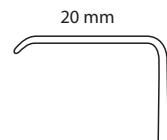

20 mm

14 cm - 5 1/2"

20.12.20



TREVALLI

**Feine Wundhaken
Delicate Retractors
Separadores finos
Ecarteurs fins
Divaricatori delicati**

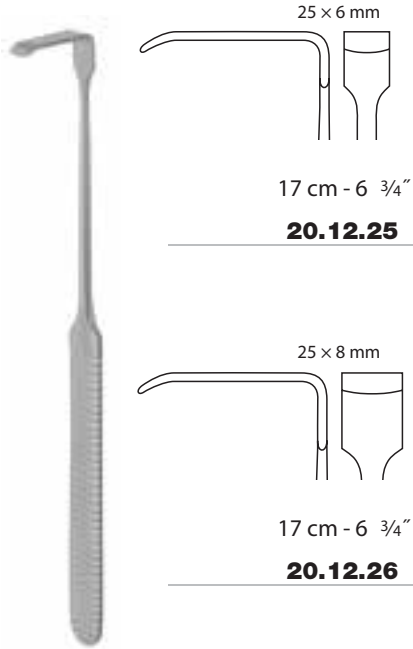

17 cm - 6 3/4"

20.12.25

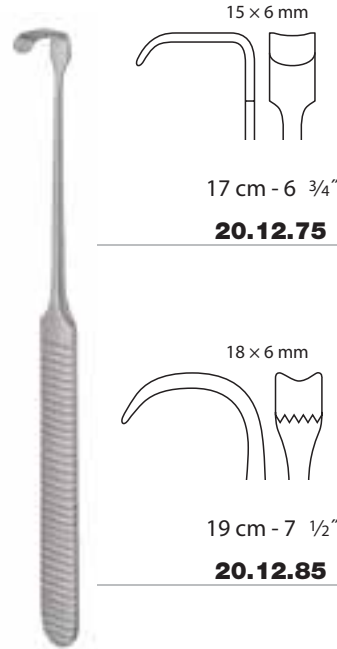

17 cm - 6 3/4"

20.12.75

Langenbeck-Green

Strandell-Stille

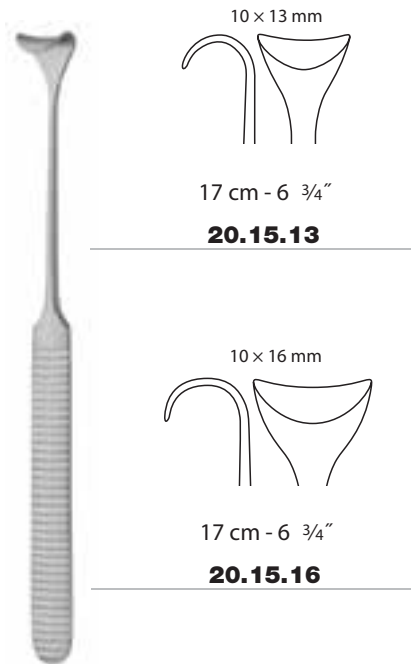

17 cm - 6 3/4"

20.15.13

17 cm - 6 3/4"

20.15.16

König



21 cm - 8 1/4"

20.17.90

Schoenborn



TREVALLI

Venenhaken
Vein retractors
Ganchos para venas
Ecarteurs à veines
Divaricatori per vene



Cushing

8 × 8 mm

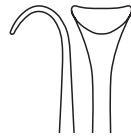

20 cm - 8"
20.17.08

8 × 10 mm

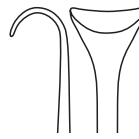

20 cm - 8"
20.17.10

9 × 12 mm

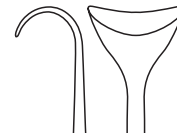

20 cm - 8"
20.17.12

24 cm - 9 1/2"

20.17.28

24 cm - 9 1/2"

20.17.30

24 cm - 9 1/2"

20.17.32

9 × 14 mm

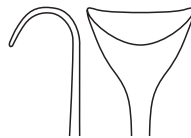

20 cm - 8"
20.17.14

11 × 16 mm

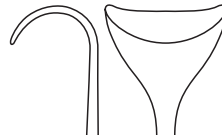

20 cm - 8"
20.17.16

11 × 18 mm



20 cm - 8"
20.17.18

24 cm - 9 1/2"

20.17.34

24 cm - 9 1/2"

20.17.36

24 cm - 9 1/2"

20.17.38

Lidhalter
Lid retractors
Retradores para párpados
Releveurs à paupières
Elevatori per palpebre



Desmarres

10 mm

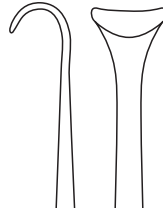

14 cm - 5 1/2"
60.05.10

0

12 mm

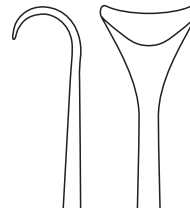

14 cm - 5 1/2"
60.05.11

1

14 mm

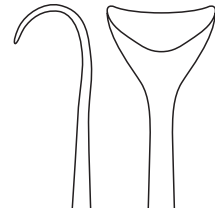

14 cm - 5 1/2"
60.05.12

2

16 mm

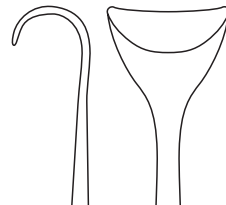

14 cm - 5 1/2"
60.05.13

3

18 mm

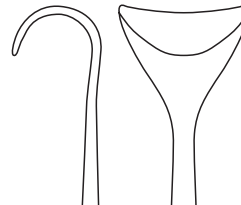

14 cm - 5 1/2"
60.05.14

4

Feine Wundhaken
Delicate Retractors
Separadores finos
Ecarteurs fins
Divaricatori delicati



TREVALLi

**Feine Wundhaken
Delicate Retractors
Separadores finos
Ecarteurs fins
Divaricatori delicati**

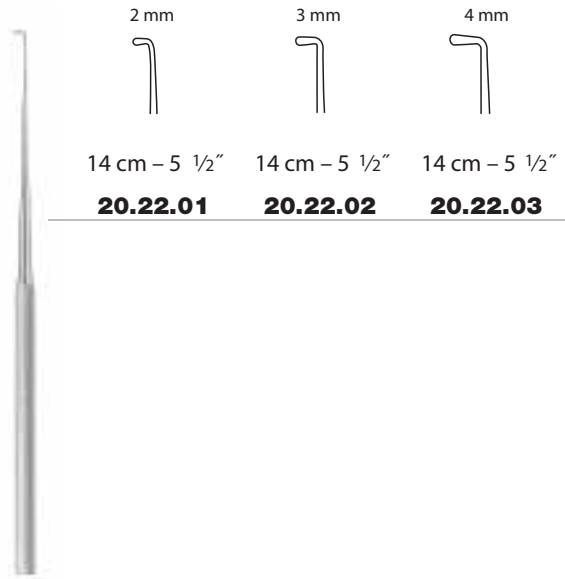

Lucae

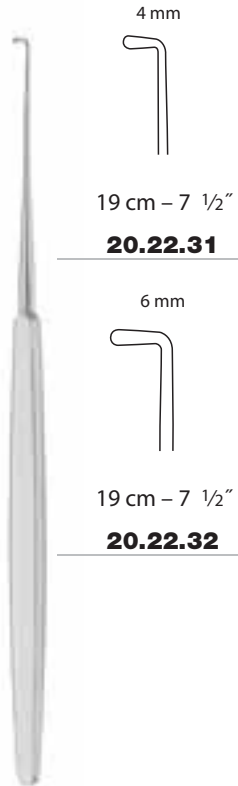

Cushing

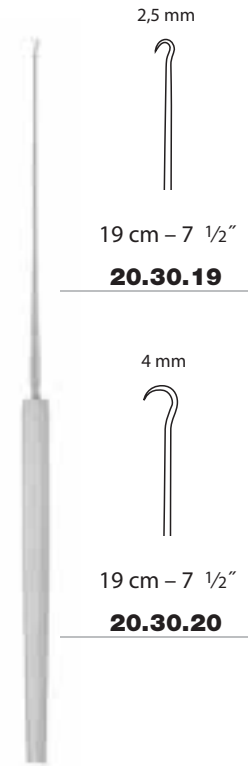

Gillies

Dura- und Hauthäkchen
Dura and skin hooks
Ganchitos para duramadre y piel
Crochets à dure-mère et peau
Uncini per dura-madre e pelle

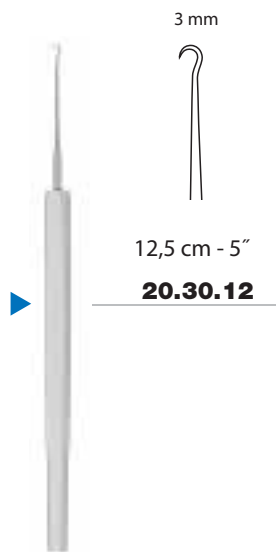

Frazier

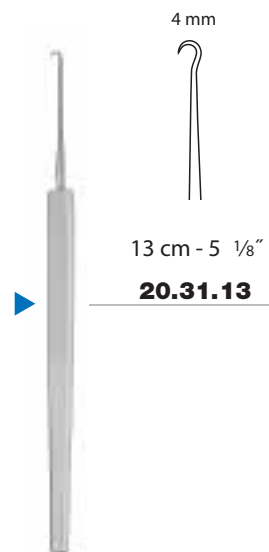

Straight

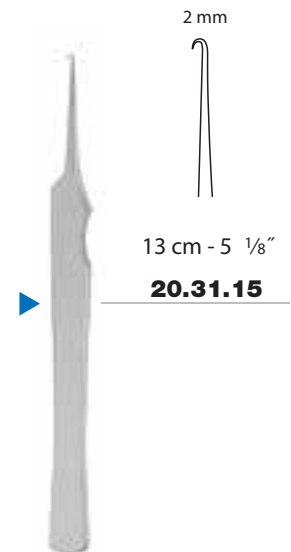

Lahey-Clinic



TREVALLi

**Feine Wundhaken
Delicate Retractors
Separadores finos
Ecarteurs fins
Divaricatori delicati**

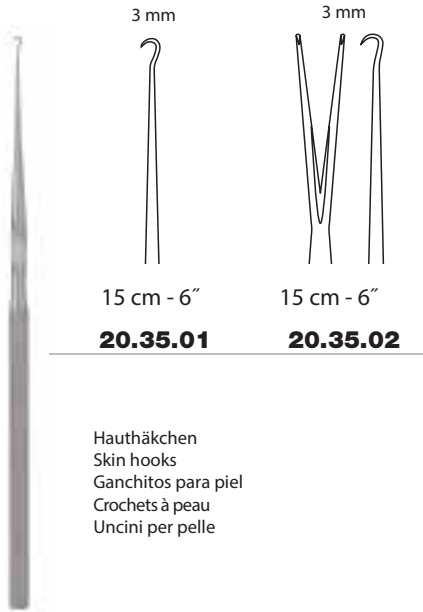

3 mm
15 cm - 6"
20.35.01

3 mm
15 cm - 6"
20.35.02

Hauthäkchen
Skin hooks
Ganchitos para piel
Crochets à peau
Uncini per pelle

Barsky

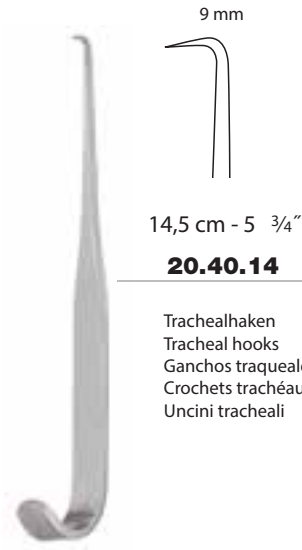

9 mm
14,5 cm - 5 3/4"
20.40.14

Trachealhaken
Tracheal hooks
Ganchos traqueales
Crochets trachéaux
Uncini tracheali

Jackson

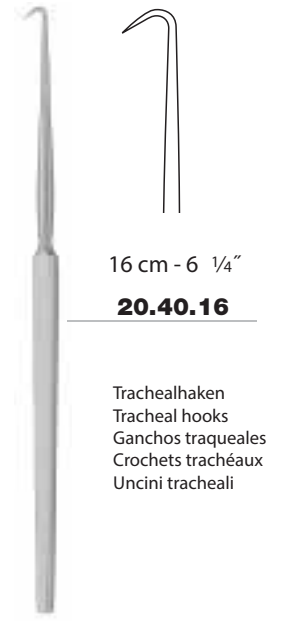

16 cm - 6 1/4"
20.40.16

Trachealhaken
Tracheal hooks
Ganchos traqueales
Crochets trachéaux
Uncini tracheali

Cottle



8 mm
14 cm - 5 1/2"
20.45.14

Bergmann

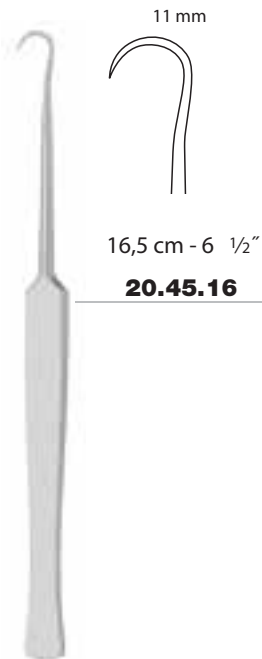

11 mm
16,5 cm - 6 1/2"
20.45.16

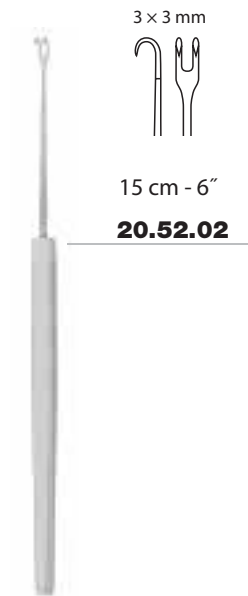

3 x 3 mm
15 cm - 6"
20.52.02

Freer

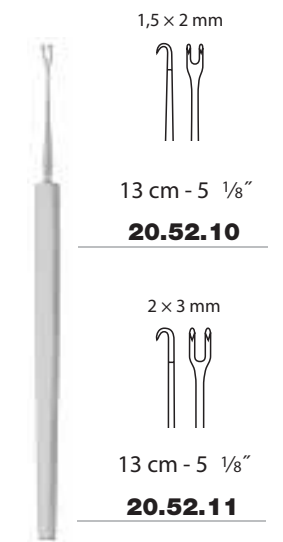

1,5 x 2 mm
13 cm - 5 1/8"
20.52.10

Guthrie

2 x 3 mm
13 cm - 5 1/8"
20.52.11



TREVALLI

Mikro Nadelhalter
Micro Needle Holders
Micro porta-agujas
Micro porte-aiguilles
Micro portaghi



Feine Wundhaken
Delicate Retractors
Separadores finos
Ecarteurs fins
Divaricatori delicati

Besonders geeignet bei der offenen Rhinoplastik für die sehr empfindliche Lappenspitze.

Particularly suitable for open rhinoplasty on the highly sensitive flap end.

Especialmente adecuado para la rinoplastia abierta de la punta muy sensible del lóbulo.

Convient en particulier pour la rhinoplastie ouverte de la pointe lobaire très sensible.

Particolarmente adatto per gli interventi aperti di rinoplastica alla punta del lobo molto sensibile.

5 mm
 16 cm - 6 1/4"
20.50.01

Joseph

5 mm 2 mm 5 mm
 17 cm - 6 3/4" 17 cm - 6 3/4"
20.50.02 20.50.05

Joseph

7 mm 10 mm
 17 cm - 6 3/4" 17 cm - 6 3/4"
20.50.07 20.50.10

4 mm 6 mm
 13 cm - 5 1/8"
20.55.13

Rollet

5 mm 6 mm 6 mm
 16 cm - 6 1/4" 16 cm - 6 1/4"
20.55.16 20.55.17

Knapp

5 mm 6 mm 6 mm
 16 cm - 6 1/4" 16 cm - 6 1/4"
20.55.26 20.55.27

Knapp

mit flexiblem Federschaft
 with flexible shaft
 con vástago flexible
 avec tige flexible
 con asta flessibile

 spitz
 sharp
 aguda
 pointu
 acuta

 stumpf
 blunt
 roma
 mousse
 smussa



TREVALLi

**Feine Wundhaken
Delicate Retractors
Separadores finos
Ecarteurs fins
Divaricatori delicati**

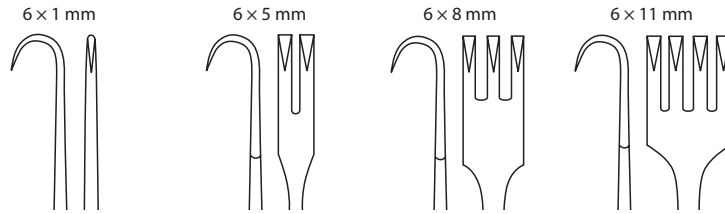

17 cm - 6 3/4" 17 cm - 6 3/4" 17 cm - 6 3/4" 17 cm - 6 3/4"
20.60.01 20.60.02 20.60.03 20.60.04

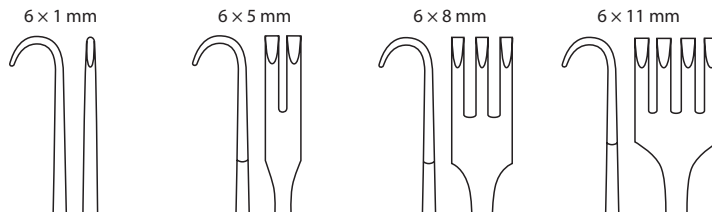

17 cm - 6 3/4" 17 cm - 6 3/4" 17 cm - 6 3/4" 17 cm - 6 3/4"
20.61.01 20.61.02 20.61.03 20.61.04

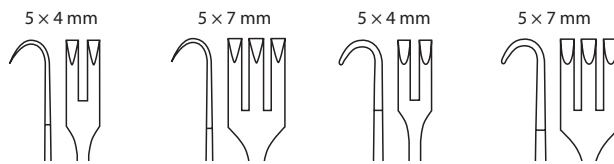

16 cm - 6 1/4" 16 cm - 6 1/4" 16 cm - 6 1/4" 16 cm - 6 1/4"
20.64.52 20.64.53 20.65.52 20.65.53



mit flexiblem Federschaft
with flexible shaft
con vástago flexible
avec tige flexible
con asta flessibile

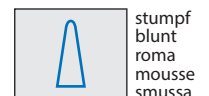



TREVALLi

**Feine Wundhaken
Delicate Retractors
Separadores finos
Ecarteurs fins
Divaricatori delicati**

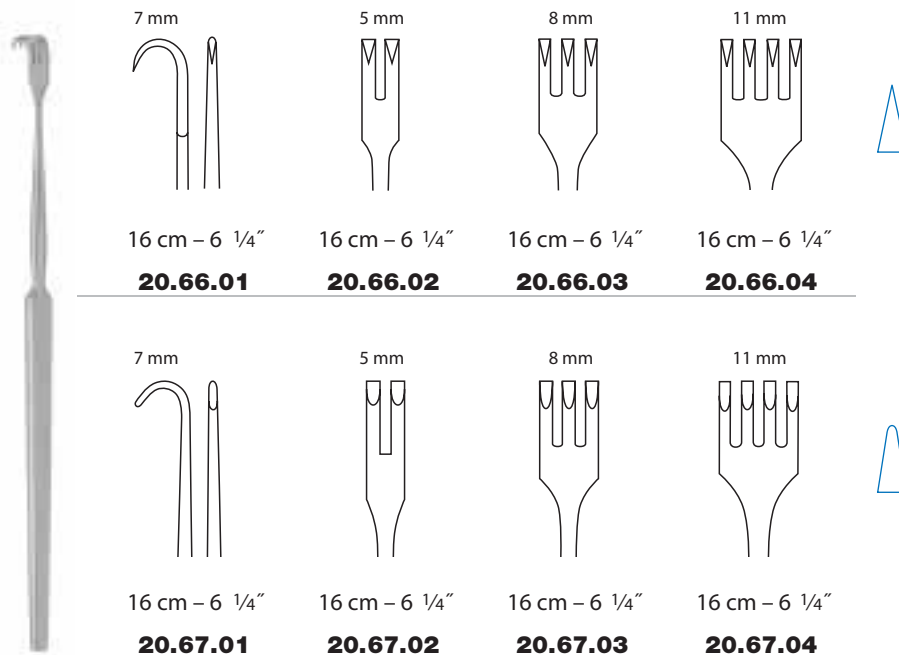
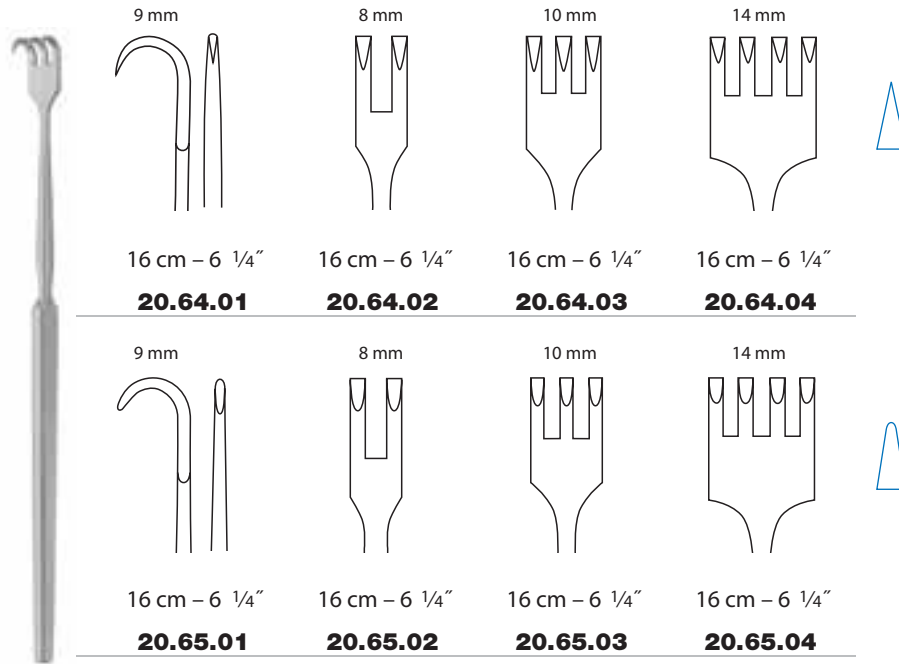

 spitz
sharp
aguda
pointu
acuta

 stumpf
blunt
roma
mousse
smussa







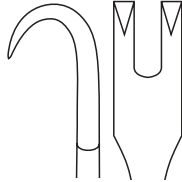
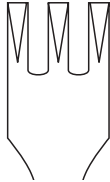
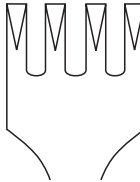
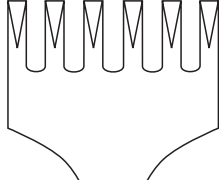

TREVALLi

**Wundhaken
Retractors
Separadores
Ecarteurs
Divaricatori**

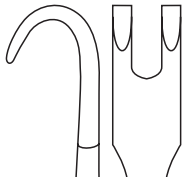
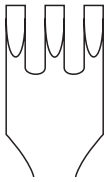
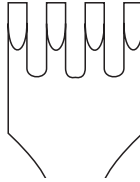
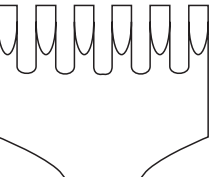

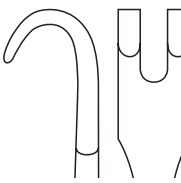
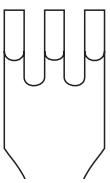
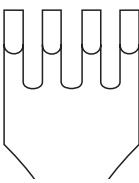
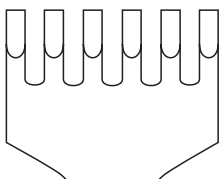
Volkman

<p>10 mm 9 mm</p>  <p>22 cm – 8 3/4"</p> <p>22.34.02</p>	<p>13 mm</p>  <p>22 cm – 8 3/4"</p> <p>22.34.03</p>	<p>18 mm</p>  <p>22 cm – 8 3/4"</p> <p>22.34.04</p>	<p>28 mm</p>  <p>22 cm – 8 3/4"</p> <p>22.34.06</p>	
<p>10 mm 9 mm</p>  <p>22 cm – 8 3/4"</p> <p>22.34.52</p>	<p>13 mm</p>  <p>22 cm – 8 3/4"</p> <p>22.34.53</p>	<p>18 mm</p>  <p>22 cm – 8 3/4"</p> <p>22.34.54</p>	<p>28 mm</p>  <p>22 cm – 8 3/4"</p> <p>22.34.56</p>	
<p>10 mm 9 mm</p>  <p>22 cm – 8 3/4"</p> <p>22.35.02</p>	<p>13 mm</p>  <p>22 cm – 8 3/4"</p> <p>22.35.03</p>	<p>18 mm</p>  <p>22 cm – 8 3/4"</p> <p>22.35.04</p>	<p>28 mm</p>  <p>22 cm – 8 3/4"</p> <p>22.35.06</p>	

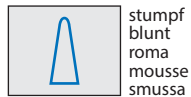
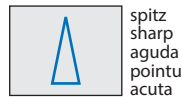



TREVALLi

Lippen- und Wangenhalter
Lip and Cheek Retractors
Separadores para labios y mejillas
Ecarteurs de lèvres et de joues
Divaricatori di labbra e guance



für Oberkiefer
for upper jaw
para mandíbula superior
pour mâchoire supérieure
per mascella superiore

21 cm - 8 1/4"

68.01.97



für Unterkiefer
for lower jaw
para mandíbula inferior
pour mâchoire inférieure
per mascella inferiore

26 cm - 10 1/4"

68.01.98



Universal
universal
universal
universel
universale

15 cm - 6"

68.01.99



TREVALLI

**Wundhaken
Retractors
Separadores
Ecarteurs
Divaricatori**



Middeldorpf

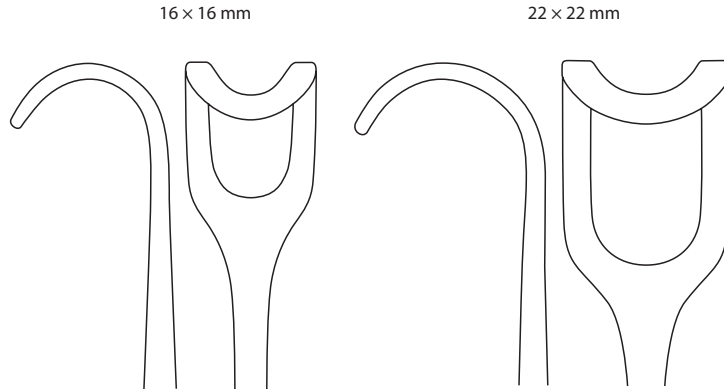

①	19,5 cm – 7 3/4"	20,5 cm – 8"
	23.33.01	23.33.02
②	20,5 cm – 8"	22,5 cm – 9"
	23.33.11	23.33.12



Middeldorpf

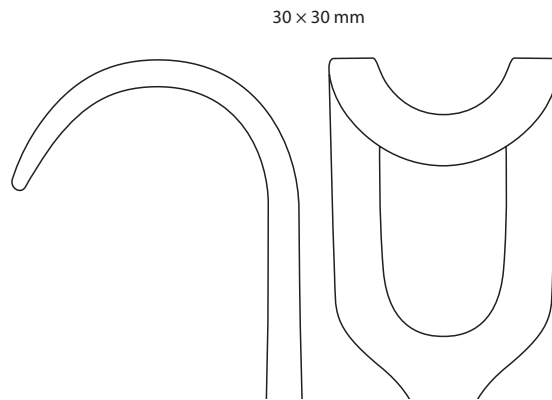

①	23 cm – 9"
	23.33.03
②	23,5 cm – 9 1/4"
	23.33.13



TREVALLi

**Wundhaken
Retractors
Separadores
Ecarteurs
Divaricatori**

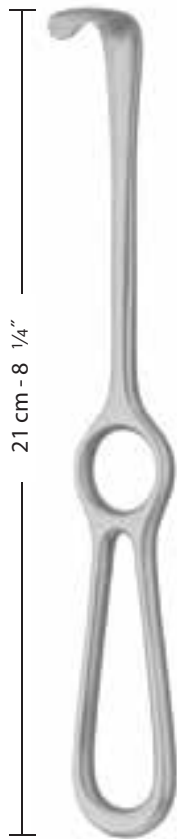

Langenbeck

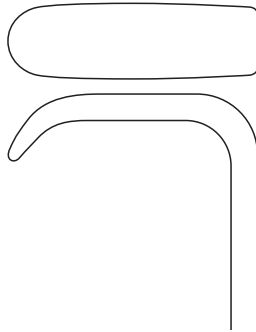

28 x 10 mm

23.05.10

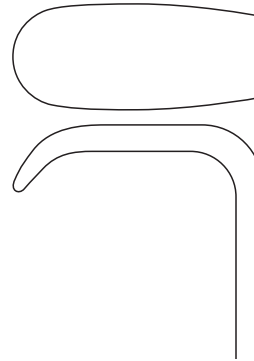

28 x 14 mm

23.05.14

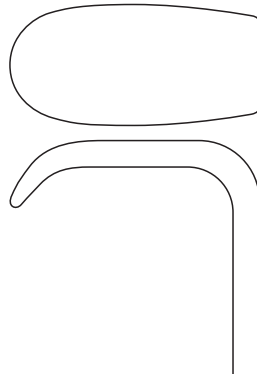

28 x 16 mm

23.05.16



TREVALLI

**Wundhaken
Retractors
Separadores
Ecarteurs
Divaricatori**

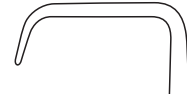

20 x 7 mm

23.25.01

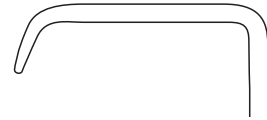

30 x 20 mm

23.25.05

30 x 7 mm

23.25.02

30 x 10 mm

23.25.03

30 x 15 mm

23.25.04

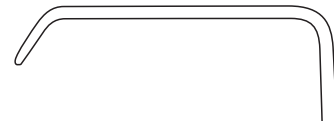

40 x 20 mm

23.25.08

40 x 10 mm

23.25.06

40 x 15 mm

23.25.07

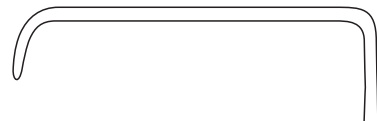

45 x 20 mm

23.25.09

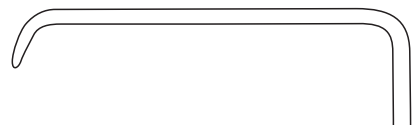

50 x 15 mm

23.25.11

50 x 10 mm

23.25.10



60 x 20 mm

23.25.12

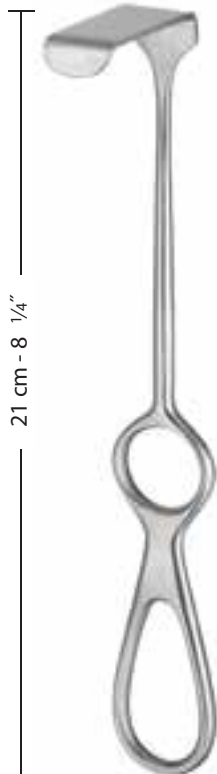

Langenbeck-Kocher



TREVALLi

**Wundhaken
Retractors
Separadores
Ecarteurs
Divaricatori**



21 cm - 8 1/4"

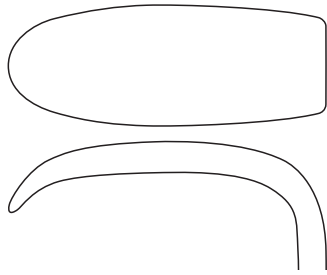

42 x 16 mm
23.06.16

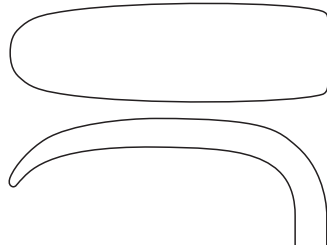

42 x 13 mm
23.06.13

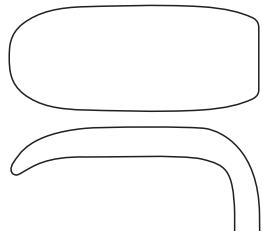

Langenbeck

33 x 14 mm
23.06.12

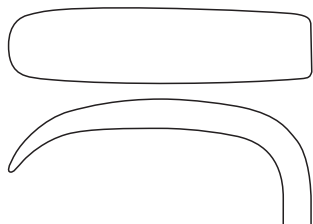

40 x 10 mm
23.06.10

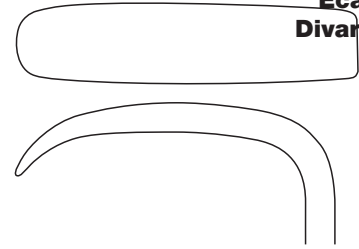

40 x 10 mm
23.07.10

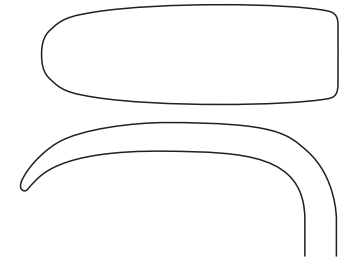

42 x 13 mm
23.07.13



21 cm - 8 1/4"

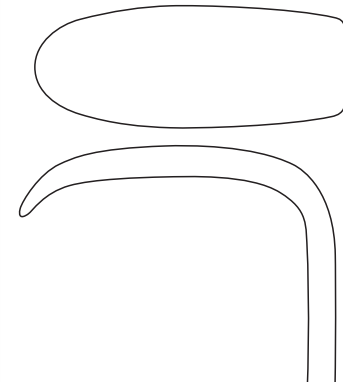

42 x 16 mm
23.07.16

Langenbeck



TREVALLi

**Wundhaken
Retractors
Separadores
Ecarteurs
Divaricatori**



Kocher

19 x 12 mm

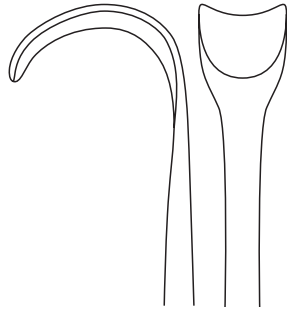

20 cm - 8"

23.40.01

21 x 15 mm

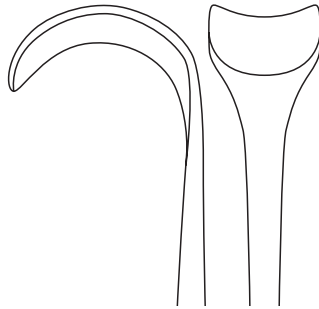

20 cm - 8"

23.40.02

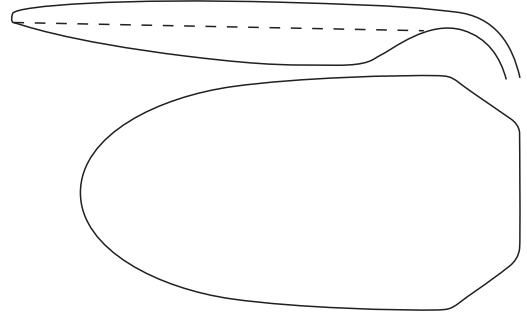

19 cm - 7 1/2"

68.82.33

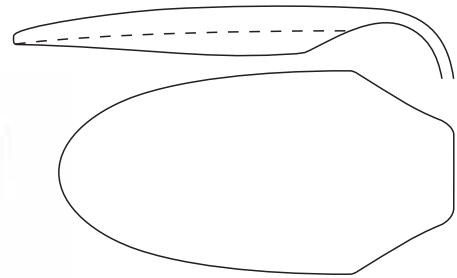

19 cm - 7 1/2"

68.82.32



Orbitahaken
Orbital hooks
Separadores orbitales
Crochets orbitaux
Divaricatori orbitale

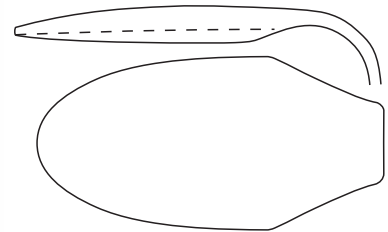

19 cm - 7 1/2"

68.82.31

Kluba



TREVALLi

**Wundhaken
Retractors
Separadores
Ecarteurs
Divaricatori**

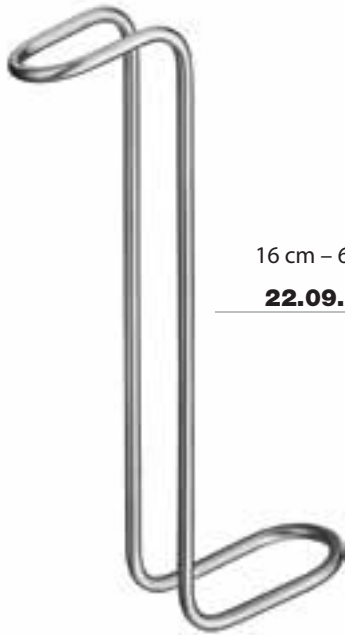

16 cm – 6 1/4"

22.09.16

Collin-Hartmann



18 cm – 7 1/8"

72.02.18

Hajek

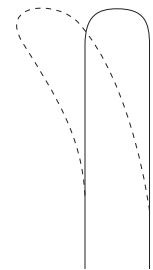

biegsam
malleable
maleable
malléable
malleabile

6 x 200 mm 12 x 200 mm

22.00.06 22.00.12

17 x 200 mm 25 x 200 mm

22.00.17 22.00.25

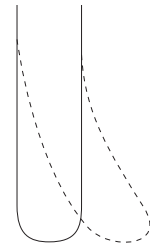



TREVALLi

**Wundhaken
Retractors
Separadores
Ecarteurs
Divaricatori**



66.65.10

Brünings-Brunk

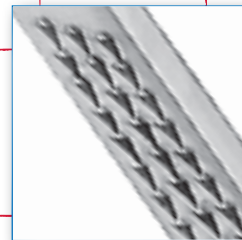



TREVALLi

Wundhaken, doppelendig
Retractors, double-ended
Separadores, dobles
Ecarteurs, doubles
Divaricatori, doppi

22.16.00

Satz komplett
Set complete
Juego completo
Jeu complet
Serie completa



Roux

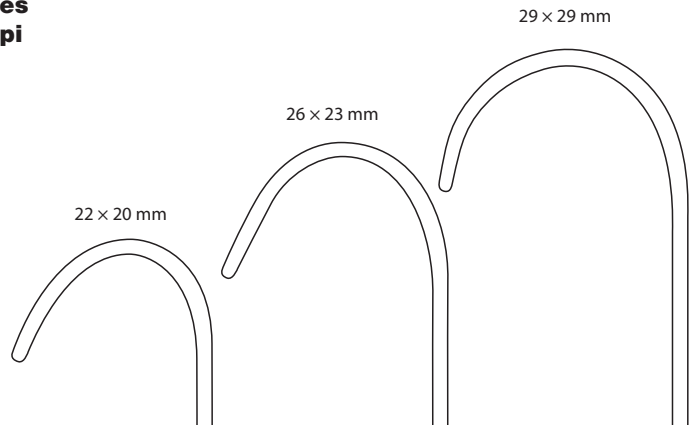

14,0 cm – 5 1/2"

15,0 cm – 6"

16,5 cm – 6 1/2"

22.16.14

22.16.15

22.16.16

1

2

3

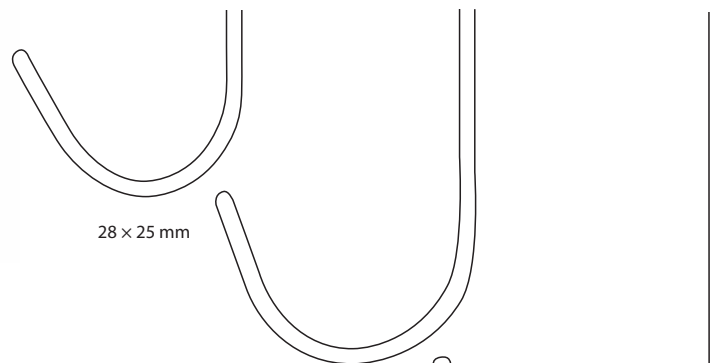

28 x 25 mm

38 x 29 mm

44 x 34 mm

15 x 15 mm

13 cm – 5 1/8"

22.16.13

0



Roux-Baby

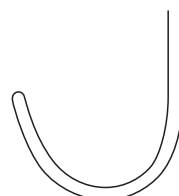

21 x 18 mm



TREVALLi

Wundspreizer
Self-retaining Retractors
Separadores autoestáticos
Ecarteurs autostatiques
Divaricatori autostatici

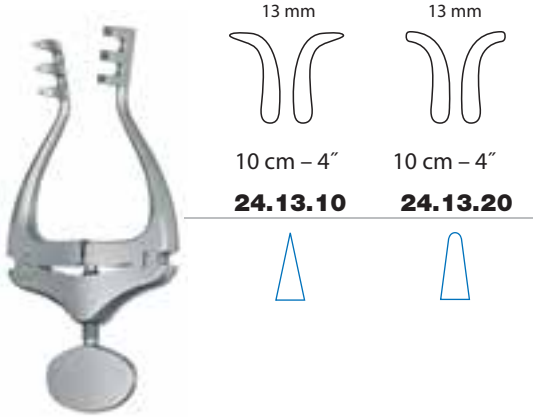

Jansen

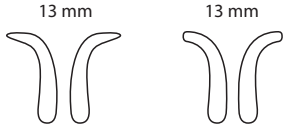

10 cm - 4" 10 cm - 4"

24.13.10 **24.13.20**

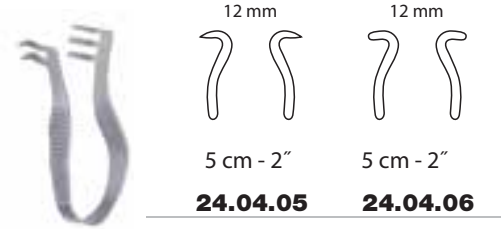

Finsen

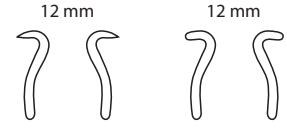

5 cm - 2" 5 cm - 2"

24.04.05 **24.04.06**

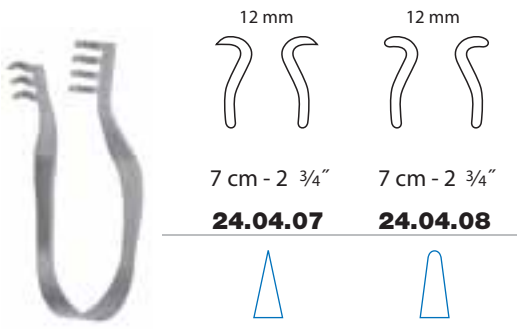

Finsen

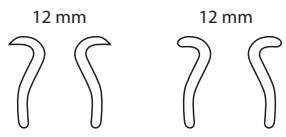

7 cm - 2 3/4" 7 cm - 2 3/4"

24.04.07 **24.04.08**

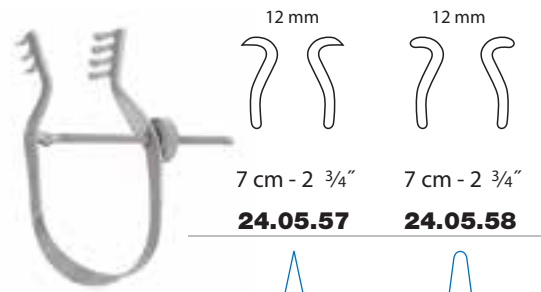

Finsen

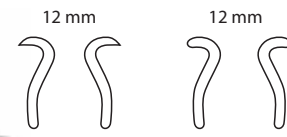

7 cm - 2 3/4" 7 cm - 2 3/4"

24.05.57 **24.05.58**

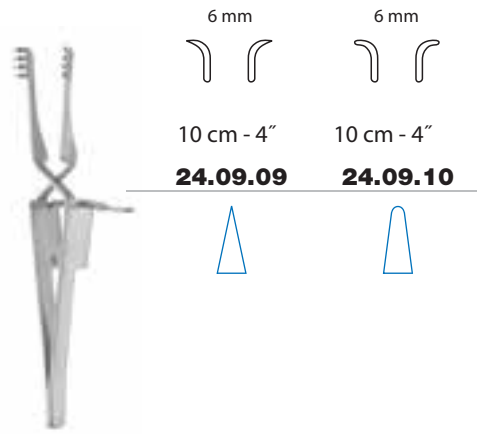

Alm

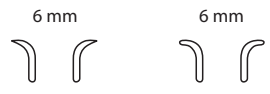

10 cm - 4" 10 cm - 4"

24.09.09 **24.09.10**

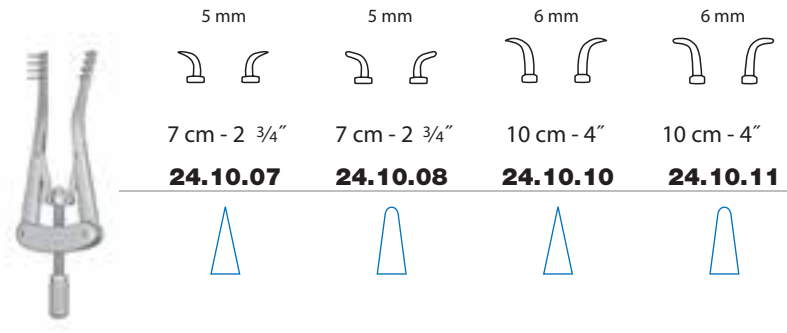

7 cm - 2 3/4" 7 cm - 2 3/4" 10 cm - 4" 10 cm - 4"

24.10.07 **24.10.08** **24.10.10** **24.10.11**

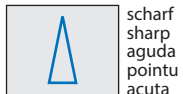
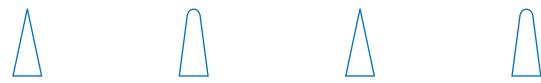

scharf
sharp
aguda
pointu
acuta



stumpf
blunt
roma
mousse
smussa



TREVALLi

Wundspreizer
Self-retaining Retractors
Separadores autoestáticos
Ecarteurs autostatiques
Divaricatori autostatici

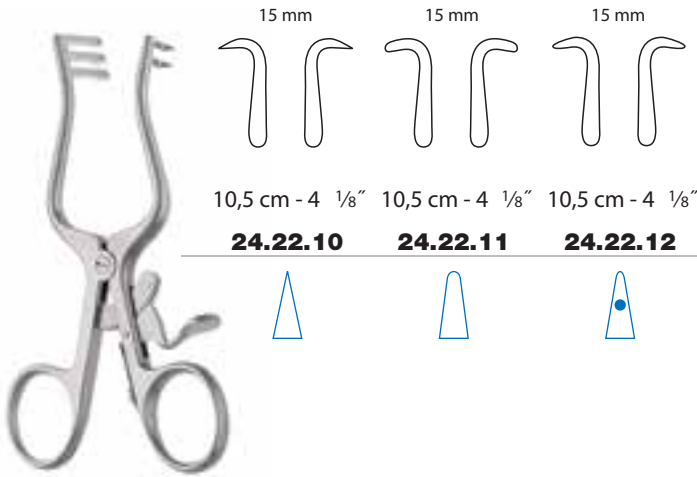

15 mm 15 mm 15 mm
10,5 cm - 4 1/8" 10,5 cm - 4 1/8" 10,5 cm - 4 1/8"
24.22.10 **24.22.11** **24.22.12**

Weitlaner

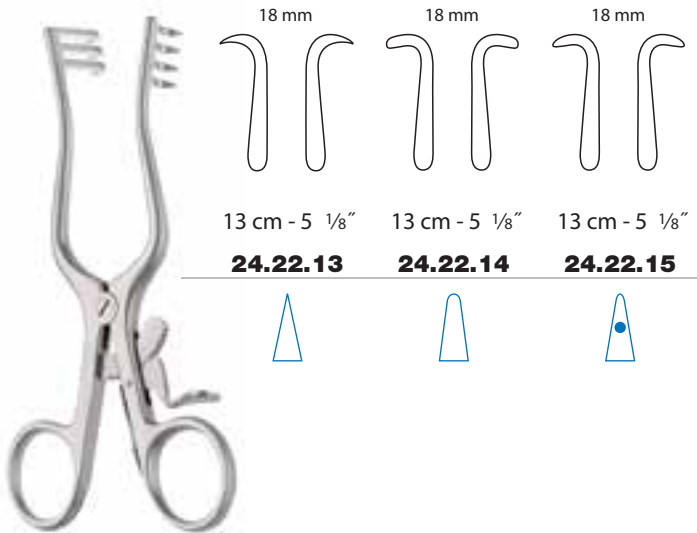

18 mm 18 mm 18 mm
13 cm - 5 1/8" 13 cm - 5 1/8" 13 cm - 5 1/8"
24.22.13 **24.22.14** **24.22.15**

Weitlaner

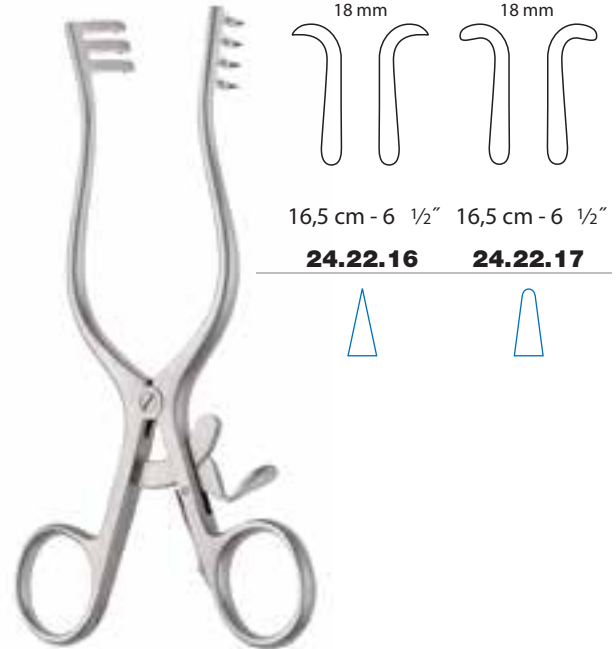

18 mm 18 mm
16,5 cm - 6 1/2" 16,5 cm - 6 1/2"
24.22.16 **24.22.17**

Weitlaner

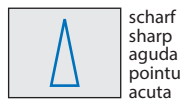

scharf
sharp
aguda
pointu
acuta



stumpf
blunt
roma
mousse
smussa



halbscharf
semi sharp
semi agudo
semi pointu
semi acuto



TREVALLi

Wundspreizer
Self-retaining Retractors
Separadores autoestáticos
Ecarteurs autostatiques
Divaricatori autostatici

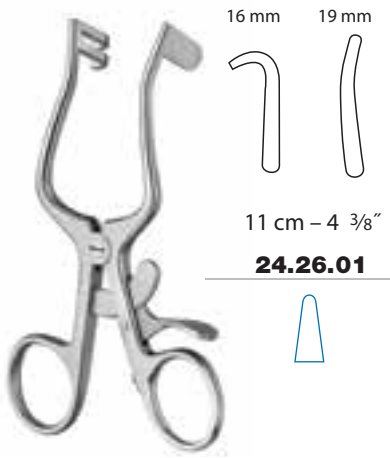

Belucci

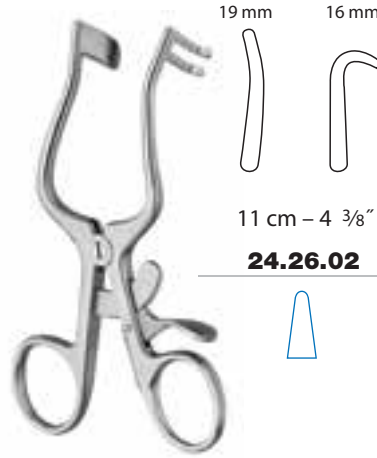

Belucci

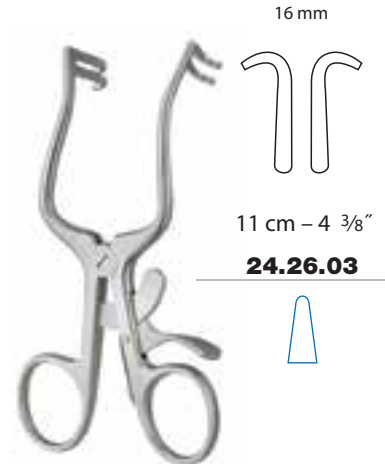

Plester



Plester

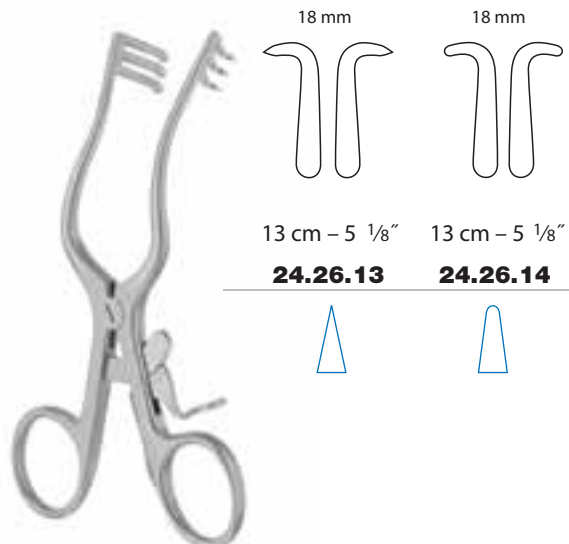

Weitlaner-Wullstein

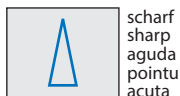

scharf
sharp
aguda
pointu
acuta



stumpf
blunt
roma
mousse
smussa



TREVALLi

Wundspreizer
Self-retaining Retractors
Separadores autoestáticos
Ecarteurs autostatiques
Divaricatori autostatici

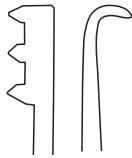

10,5 cm - 4 1/8"

24.26.05



Wigand

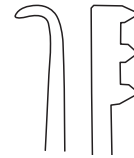

10,5 cm - 4 1/8"

24.26.06



Wigand

Orbita Gelenksperrer
Orbital self-retaining retractors
Separadores autoestáticos para orbita con articulación
Ecarteurs orbitaux autostatiques avec articulation
Divaricatori autostatici per orbita con articolazione



23 mm 29 mm

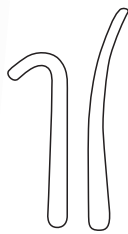

18 cm - 7 1/8"

24.30.30



29 mm 23 mm

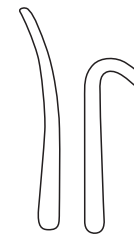

18 cm - 7 1/8"

24.30.31



halbscharf
semi sharp
semi agudo
semi pointu
semi acuto



TREVALLi

**Unterbindungsnadeln
Ligature Needles
Agujas para ligaduras
Aiguilles à ligature
Aghi per legatura**



Durham



Durham



Kronecker



Kronecker

 für die linke Hand
for left hand
para la mano izquierda
pour la main gauche
per la mano sinistra

 für die rechte Hand
for right hand
para la mano derecha
pour la main droite
per la mano destra



TREVALLi

**Unterbindungsnadeln
Ligature Needles
Agujas para ligaduras
Aiguilles à ligature
Aghi per legatura**

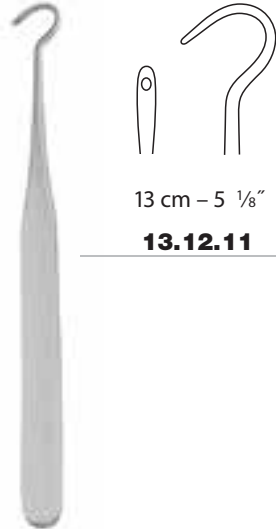

13 cm – 5 1/8"

13.12.11



13 cm – 5 1/8"



13.12.14



13 cm – 5 1/8"



13.12.15



für die linke Hand
for left hand
para la mano izquierda
pour la main gauche
per la mano sinistra



für die rechte Hand
for right hand
para la mano derecha
pour la main droite
per la mano destra



TREVALLi

**Unterbindungsnadeln
Ligature Needles
Agujas para ligaduras
Aiguilles à ligature
Aghi per legatura**



1:1



1:1



20 cm - 8"
13.12.22



1:1



20 cm - 8"
13.12.24



1:1



20 cm - 8"
13.12.23

Deschamps-Baby



1:1



20 cm - 8"
13.12.25

Deschamps-Baby



1:1



20 cm - 8"
13.12.32



1:1



20 cm - 8"
13.12.33

Deschamps



für die linke Hand
for left hand
para la mano izquierda
pour la main gauche
per la mano sinistra



für die rechte Hand
for right hand
para la mano derecha
pour la main droite
per la mano destra



TREVALLi

**Unterbindungsnadeln
Ligature Needles
Agujas para ligaduras
Aiguilles à ligature
Aghi per legatura**



1:1

Deschamps



1:1

 20 cm – 8"
13.12.34

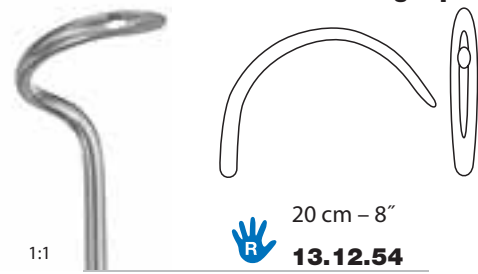

1:1

 20 cm – 8"
13.12.54



1:1

 20 cm – 8"
13.12.35

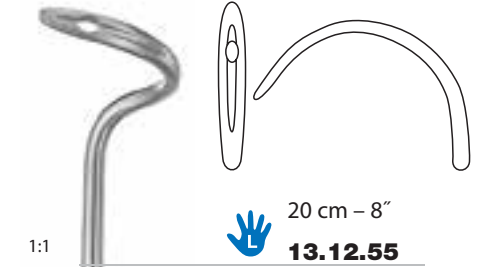

1:1

 20 cm – 8"
13.12.55



1:1

 20 cm – 8"
13.12.52



1:1

 20 cm – 8"
13.12.53

 für die linke Hand
for left hand
para la mano izquierda
pour la main gauche
per la mano sinistra

 für die rechte Hand
for right hand
para la mano derecha
pour la main droite
per la mano destra



TREVALLi



**Führungshohlsonden, Fadenfänger
Ligature Guides, Ligature Catcher
Sondas conductoras acanaladas, Saca-hilos
Sondes conductrices cannelées, Porte-ligature
Sonde conduttrici scanalate, Portalegature**

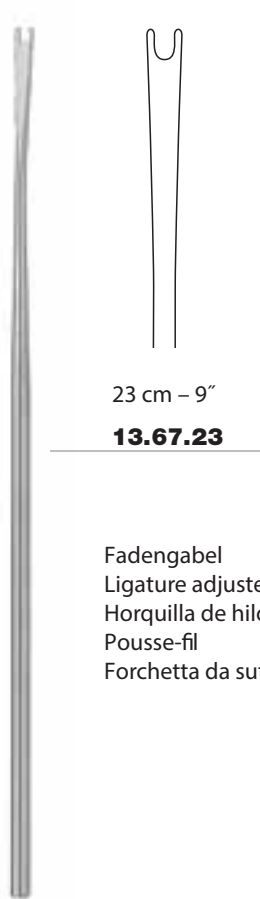
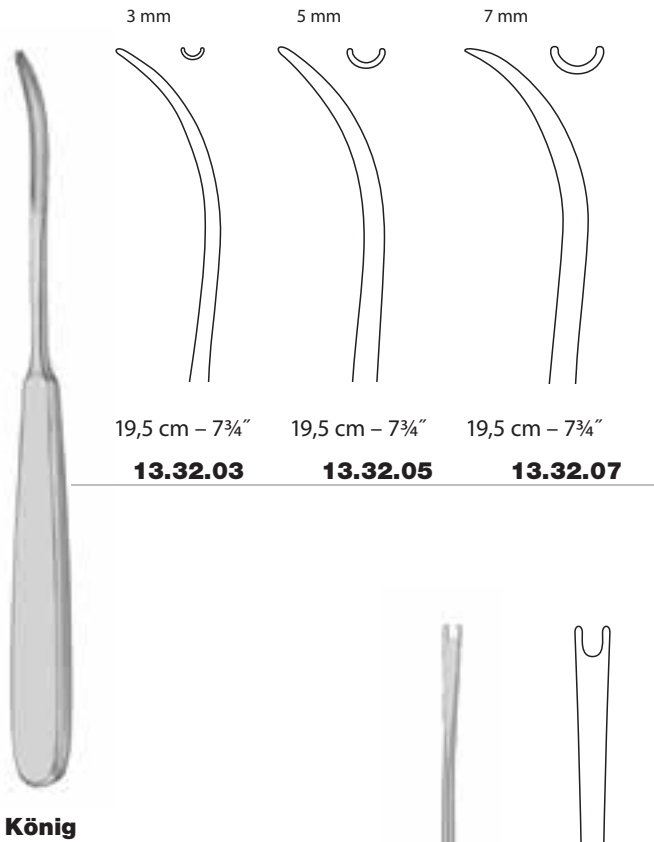

Fadengabel
Ligature adjuster
Horquilla de hilos
Pousse-fil
Forchetta da sutura



Fadenfänger
Ligature catcher
Saca-hilos
Porte-ligature
Portalegature

Mod. Wien



TREVALLi

Nahtpinzetten
Suturing Forceps
Pinzas para sutura
Pinces à suture
Pinze per sutura

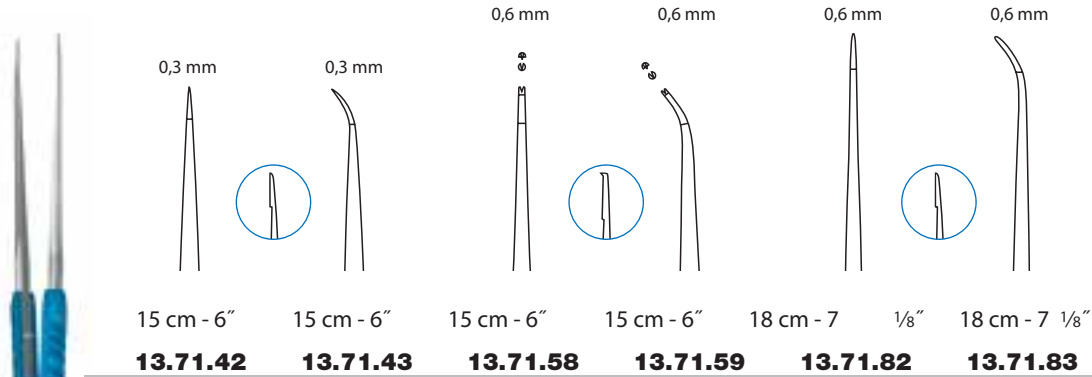

Leichtmetall-Instrumente mit blau eloxierten Rundgriffen
 Light-weight instruments with blue anodized round handles
 Instrumentos de metal ligero con mangos redondos anodizados azul
 Instruments en métal léger, avec manches ronds anodisés en bleu
 Strumenti di metallo leggero con manici rotondi, anodizzati blu

micro 2000



- geringes Gewicht
- gut ausbalanciert
- ermüdungsfreies Arbeiten
- extremely light weight
- well balanced
- fatigueless working
- peso muy ligero
- bien equilibrados
- trabajo sin fatiga
- poids léger
- bien équilibrés
- travail sans fatigue
- peso minimo
- equilibrio perfetto
- non affaticano la mano

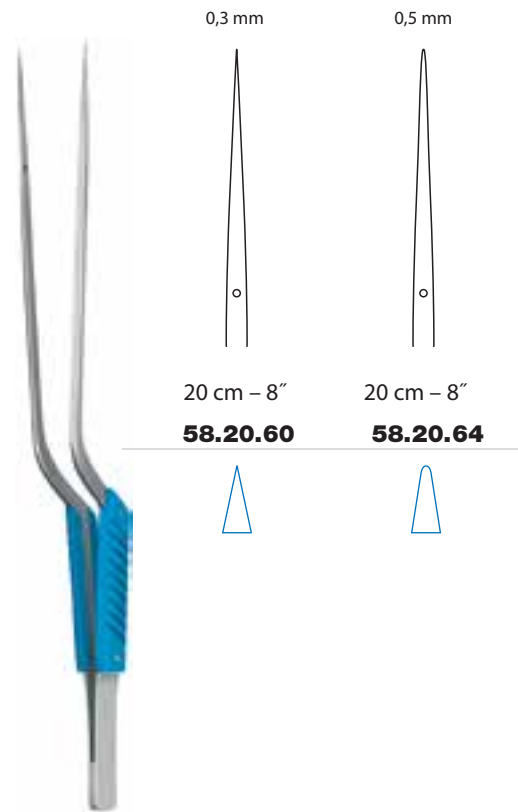

micro 2000

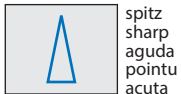



TREVALLi

Nahtpinzetten
Suturing Forceps
Pinzas para sutura
Pinces à suture
Pinze per sutura



0,3 mm



12 cm - 4¾"

13.71.22

0,3 mm



12 cm - 4¾"

13.71.23

micro 2000



0,8 mm

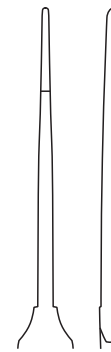

18 cm - 7 1/8"

13.71.86

Austin



TREVALLi

**Nahtpinzetten
Suturing Forceps
Pinzas para sutura
Pinces à suture
Pinze per sutura**

	0,3 mm 	0,3 mm 	0,3 mm 2:1 	0,3 mm 2:1
	12 cm - 4 3/4"	12 cm - 4 3/4"	12 cm - 4 3/4"	12 cm - 4 3/4"
	13.71.50	13.71.51	13.71.52	13.71.53
<hr/>				
	15 cm - 6"	15 cm - 6"	15 cm - 6"	15 cm - 6"
	13.71.60	13.71.61	13.71.62	13.71.63
<hr/>				
	18 cm - 7 1/8"	18 cm - 7 1/8"	18 cm - 7 1/8"	18 cm - 7 1/8"
	13.71.70	13.71.71	13.71.72	13.71.73

	15 cm - 6"	15 cm - 6"
	13.71.05	13.71.15
<hr/>		
	18 cm - 7 1/8"	18 cm - 7 1/8"
	13.71.08	13.71.18
<hr/>		
	21 cm - 8 1/4"	21 cm - 8 1/4"
	13.71.11	13.71.21

mit Gewicht
with weight
con peso
avec poids
con peso

		0,6 mm
		23 cm - 9"
		13.71.84



TREVALLi

Fadenscheren
Stitch Scissors
Tijeras para hilos
Ciseaux à ligature
Forbici per legature



Spencer



9 cm - 3 1/2"

14.06.09



10,5 cm - 4 1/8"

14.06.10

14.06.60



12 cm - 4 3/4"

14.06.12

14.06.62

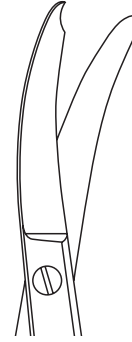

12 cm - 4 3/4"

14.07.12

standard

"HM"



Littauer

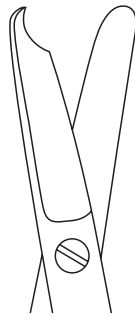

13 cm - 5 1/8"

14.06.13

standard



Locklin

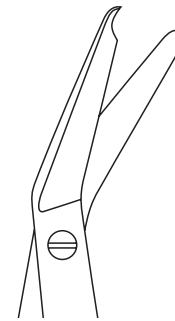

15 cm - 6"

14.07.15

standard



TREVALLi

Drahtscheren
Wire Cutting Scissors
Tijeras para cortar alambre
Ciseaux coupe-fil
Forbici per fili d'acciaio



Beebee



10,5 cm – 4 1/8"

14.24.10



10,5 cm – 4 1/8"

14.24.20



10,5 cm – 4 1/8"

14.26.10



10,5 cm – 4 1/8"

14.26.20



10,5 cm – 4 1/8"

14.25.10

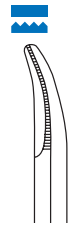

10,5 cm – 4 1/8"

14.25.20



10,5 cm – 4 1/8"

14.27.10



10,5 cm – 4 1/8"

14.27.20



Beebee

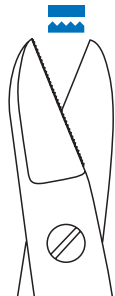

12,5 cm – 5"

14.24.12



12,5 cm – 5"

14.24.22



12,5 cm – 5"

14.26.12



12,5 cm – 5"

14.26.22

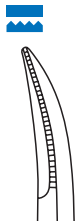

12,5 cm – 5"

14.25.12

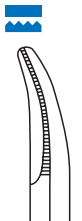

12,5 cm – 5"

14.25.22



12,5 cm – 5"

14.27.12



12,5 cm – 5"

14.27.22



Eine Schneide gezahnt
One blade serrated
Una hoja dentada
Une lame dentelée
Una lama dentellata



TREVALLi

Drahtscheren, Drahtspannzangen
Wire Cutting Scissors, Wire Twisting Forceps
Tijeras para cortar alambre, Pinzas tensoras de alambre
Ciseaux coupe-fil, Pincas serre-fil
Forbici per fili d'acciaio, Pinze tendifili d'acciaio

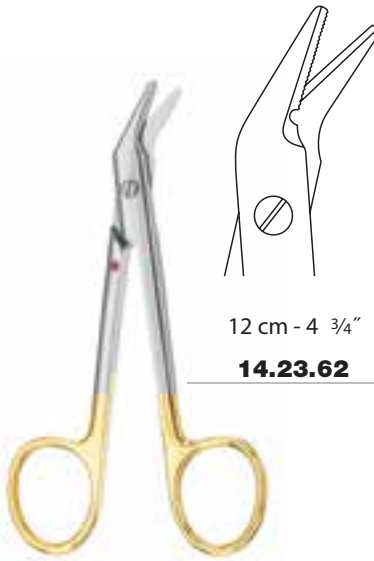

12 cm - 4 3/4"

14.23.62

Universal "HM"

0,3 mm 0,8 mm



13 cm - 5 1/8"

14.20.10

Harvey



12 cm - 4 3/4"

14.23.12

Universal

max. Ø	harte Drähte hard wires alambres duros fils durs fili duri
max. Ø	weiche Drähte soft wires alambres blandos fils mous fili molli



15 cm - 6"

14.40.65

Niro "HM"



17 cm - 6 3/4"

14.44.67

Medicon "HM"

"HM" Hartmetall
Tungsten carbide
Carburo de tungsteno
Carbure de tungstène
Carburo di tungsteno

 Eine Schneide gezahnt
One blade serrated
Una hoja dentada
Une lame dentelée
Una lama dentellata



TREVALLi

Flachzange, Drahtknifzangen, Universal-Kramponzange
Flat Nose Pliers, Wire Cutting Pliers, Universal Pin Bending Pliers
Alicate plano, Pinzas para cortar alambre, Alicates universal para grapas
Pince plate, Pince coupe-fil, Pince universelle pour crampons
Tenaglia piatta, Tenaglie tagliafili, Pinza universale per cramponi



14 cm – 5 1/2"
14.46.14



16 cm – 6 1/4"
390.70.20

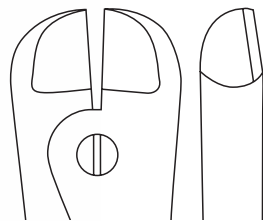

17,5 cm – 7"
14.30.17

"HM"

1,6 mm 2,0 mm

max. Ø

harte Drähte
 hard wires
 alambres duros
 fils durs
 fili duri

max. Ø

weiche Drähte
 soft wires
 alambres blandos
 fils mous
 fili molli

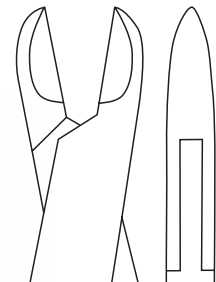

12 cm – 4 3/4"
14.30.11

"HM"

0,6 mm 1,0 mm

"HM"

Hartmetall
 Tungsten carbide
 Carburo de tungsteno
 Carbure de tungstène
 Carburio di tungsteno



TREVALLi

**Chirurgische Nadeln
Surgical Needles
Agujas quirúrgicas
Aiguilles chirurgicales
Aghi chirurgici**

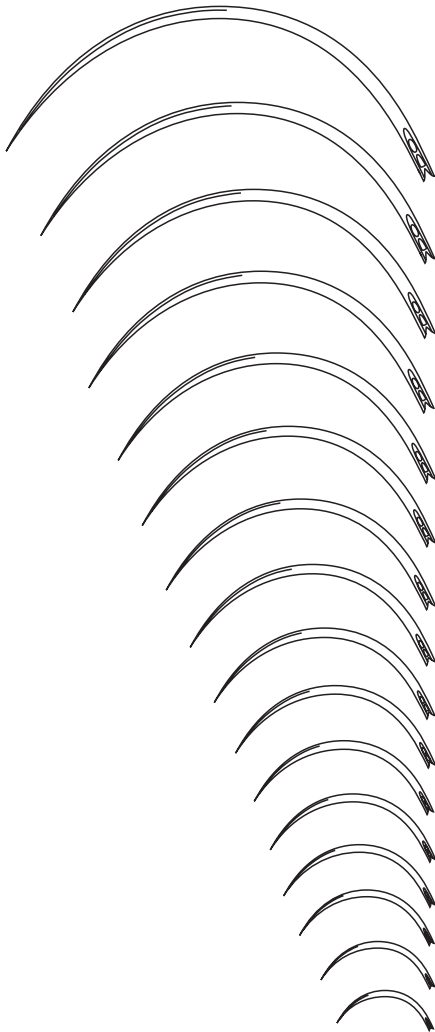

- # 1 **14.60.01**
- # 2 **14.60.02**
- # 3 **14.60.03**
- # 4 **14.60.04**
- # 5 **14.60.05**
- # 6 **14.60.06**
- # 7 **14.60.07**
- # 8 **14.60.08**
- # 9 **14.60.09**
- # 10 **14.60.10**
- # 11 **14.60.11**
- # 12 **14.60.12**
- # 13 **14.60.13**
- # 14 **14.60.14**
- # 15 **14.60.15**
- # 16 **14.60.16**



B  gebogen $\frac{3}{8}$ Kreis
curved $\frac{3}{8}$ circle
curvas $\frac{3}{8}$ círculo
courbes $\frac{3}{8}$ cercle
curvi $\frac{3}{8}$ cerchio

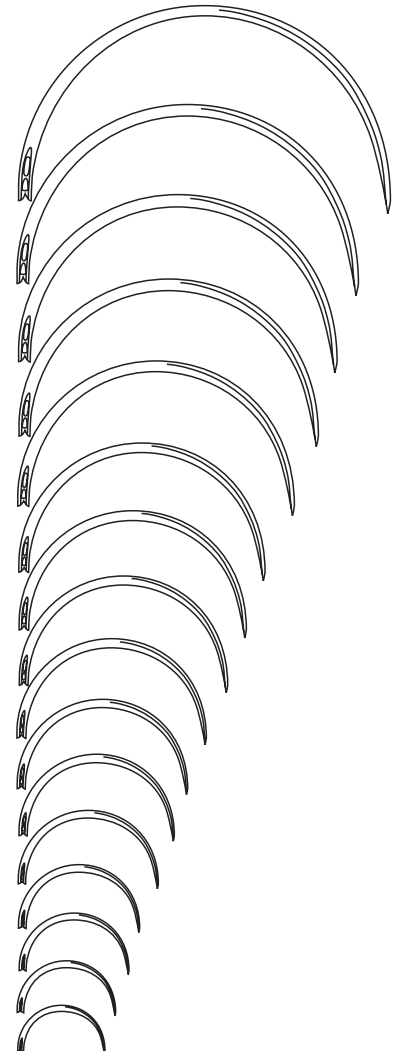

- 14.62.01** # 1
- 14.62.02** # 2
- 14.62.03** # 3
- 14.62.04** # 4
- 14.62.05** # 5
- 14.62.06** # 6
- 14.62.07** # 7
- 14.62.08** # 8
- 14.62.09** # 9
- 14.62.10** # 10
- 14.62.11** # 11
- 14.62.12** # 12
- 14.62.13** # 13
- 14.62.14** # 14
- 14.62.15** # 15
- 14.62.16** # 16



gebogen $\frac{1}{2}$ Kreis
curved $\frac{1}{2}$ circle
curvas $\frac{1}{2}$ círculo
courbes $\frac{1}{2}$ cercle
curvi $\frac{1}{2}$ cerchio

G 

P_x Verpackungseinheit "X" Stück
Packing unit "X" pieces
Paquete de "X" unidades
Emballage de "X" pièces
Confezione da "X" pezzi



TREVALLi

**Arterienklemmen
Hemostatic Forceps
Pinzas hemostáticas
Pinces hémostatiques
Pinze emostatiche**



1:1

Diethrich



4,5 cm - 1 3/4"

15.10.08

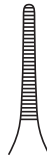

5 cm - 2"

15.10.12

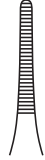

5,5 cm - 2 1/8"

15.10.16



1:1

Diethrich



4,5 cm - 1 3/4"

15.11.08

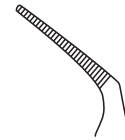

5 cm - 2"

15.11.12

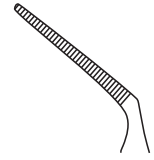

5,5 cm - 2 1/8"

15.11.16

50g

Schließdruck
Closing pressure
Presión de cierre
Force de fermeture
Pressione di chiusura

3g

Gewicht
Weight
Peso
Poids
Peso

**Bulldog-Klemmen
Bulldog clamps
Clamps Bulldog
Clamps Bulldog
Pinze Bulldog**



1:1

DeBakey "AT"

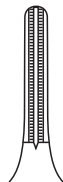

7,5 cm - 3"

15.16.07

8,5 cm - 3 3/8"

15.16.08

10,5 cm - 4 1/8"

15.16.10

12,0 cm - 4 3/4"

15.16.12

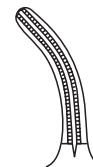

7,0 cm - 2 3/4"

15.17.07

8,0 cm - 3 1/8"

15.17.08

10,0 cm - 4"

15.17.10

11,5 cm - 4 1/2"

15.17.12

1:1

DeBakey "AT"



TREVALLi

**Arterienklemmen
Hemostatic Forceps
Pinzas hemostáticas
Pinces hémostatiques
Pinze emostatiche**



14 cm – 5 1/2"

14 cm – 5 1/2"

15.24.14

15.25.14

Crile-Baby

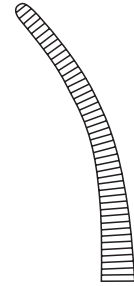

14 cm – 5 1/2"

14 cm – 5 1/2"

15.28.14

15.29.14

Pean-Baby

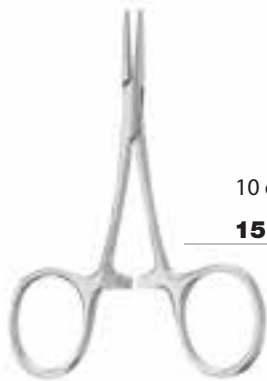

10 cm – 4"

10 cm – 4"

10 cm – 4"

10 cm – 4"

15.32.09

15.33.09

15.34.09

15.35.09

**Hartmann
(Baby-Mosquito)**



TREVALLi

**Arterienklemmen
Hemostatic Forceps
Pinzas hemostáticas
Pinces hémostatiques
Pinze emostatiche**



Micro-Halsted

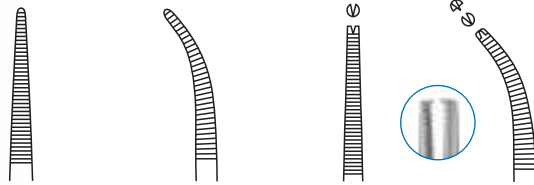

12,5 cm - 5" 12,5 cm - 5" 12,5 cm - 5" 12,5 cm - 5"
15.40.12 15.41.12 15.42.12 15.43.12



ULTRA

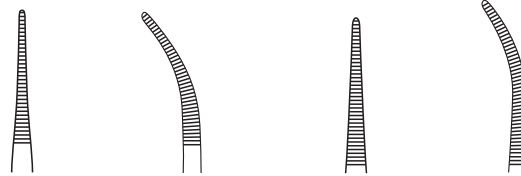

10 cm - 4" 10 cm - 4" 12,5 cm - 5" 12,5 cm - 5"
15.44.10 15.45.10 15.44.22 15.45.22

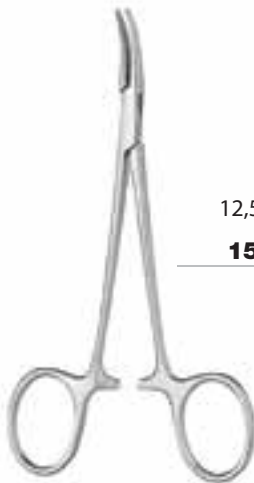

Halsted-Mosquito

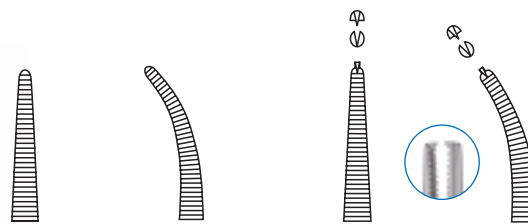

12,5 cm - 5" 12,5 cm - 5" 12,5 cm - 5" 12,5 cm - 5"
15.44.12 15.45.12 15.46.12 15.47.12

- superfeine Modelle
- höchste Präzision
- geringes Gewicht

- ultra delicate models
- highest precision
- light weight

- modelos super finos
- máxima precisión
- peso ligero

- modèles superfins
- précision maximum
- poids léger

- modelli molto delicati
- alta precisione
- peso minimo



TREVALLi

Arterienklemmen
Hemostatic Forceps
Pinzas hemostáticas
Pinces hémostatiques
Pinze emostatiche

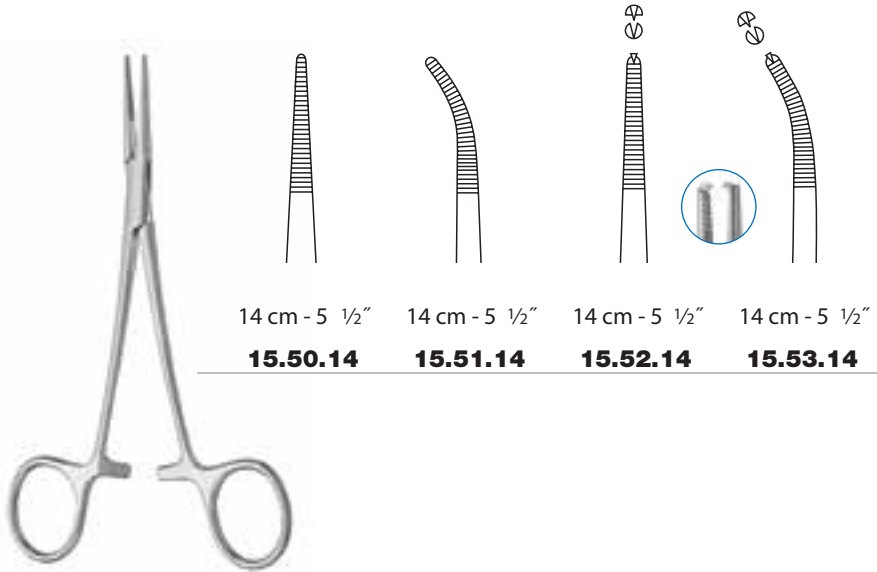

14 cm - 5 1/2"

15.50.14

14 cm - 5 1/2"

15.51.14

14 cm - 5 1/2"

15.52.14

14 cm - 5 1/2"

15.53.14

Providence-Hospital

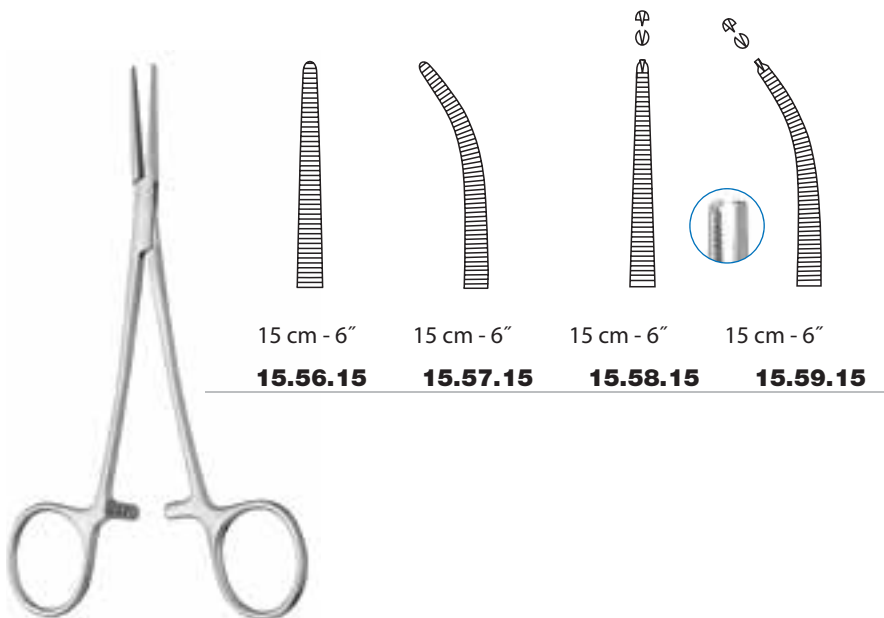

15 cm - 6"

15.56.15

15 cm - 6"

15.57.15

15 cm - 6"

15.58.15

15 cm - 6"

15.59.15

Leriche



TREVALLI

Arterienklemmen
Hemostatic Forceps
Pinzas hemostáticas
Pincas hémostatiques
Pinze emostatiche

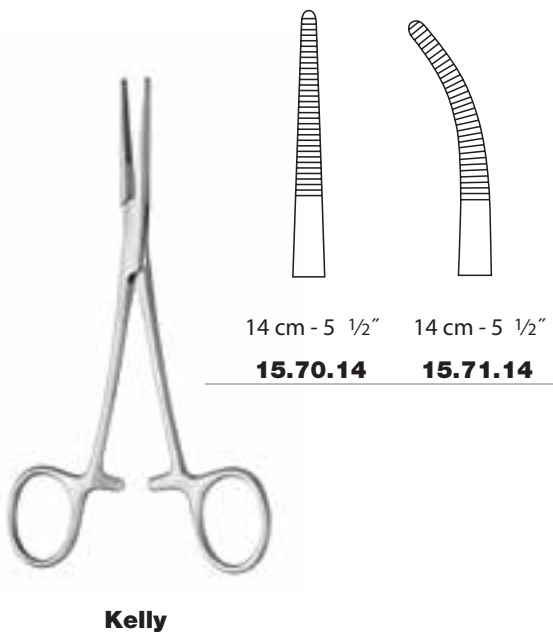
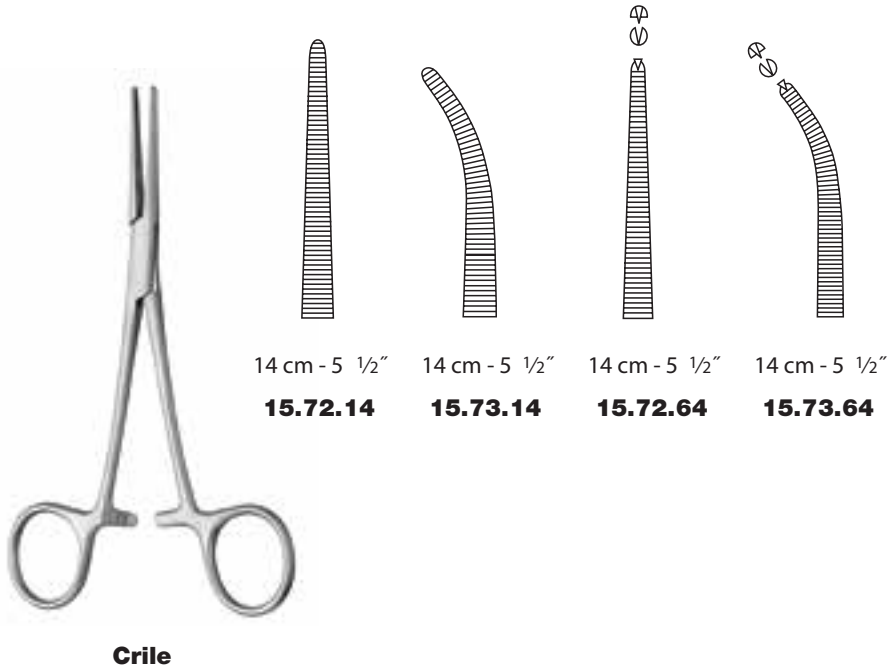



TREVALLI

Arterienklemmen
Hemostatic Forceps
Pinzas hemostáticas
Pinces hémostatiques
Pinze emostatiche



Rankin-Crile



16 cm - 6 1/4"

15.72.16



16 cm - 6 1/4"

15.73.16



16 cm - 6 1/4"

15.72.66

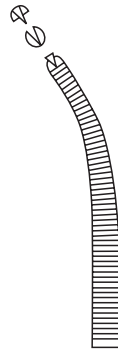

16 cm - 6 1/4"

15.73.66



Fuchsig

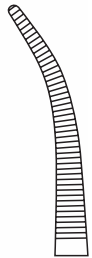

19 cm - 7 1/2"

16.61.19



Pean



13 cm - 5 1/8"

16.10.13



14 cm - 5 1/2"

16.10.14



13 cm - 5 1/8"

16.11.13



14 cm - 5 1/2"

16.11.14



TREVALLi

Arterienklemmen
Hemostatic Forceps
Pinzas hemostáticas
Pincès hémostatiques
Pinze emostatiche

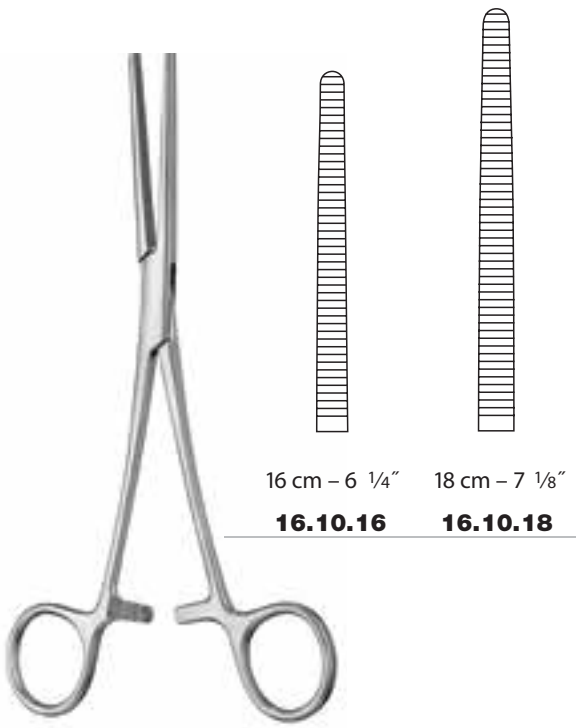

16 cm – 6 1/4" 18 cm – 7 1/8"
16.10.16 16.10.18

Rochester-Pean

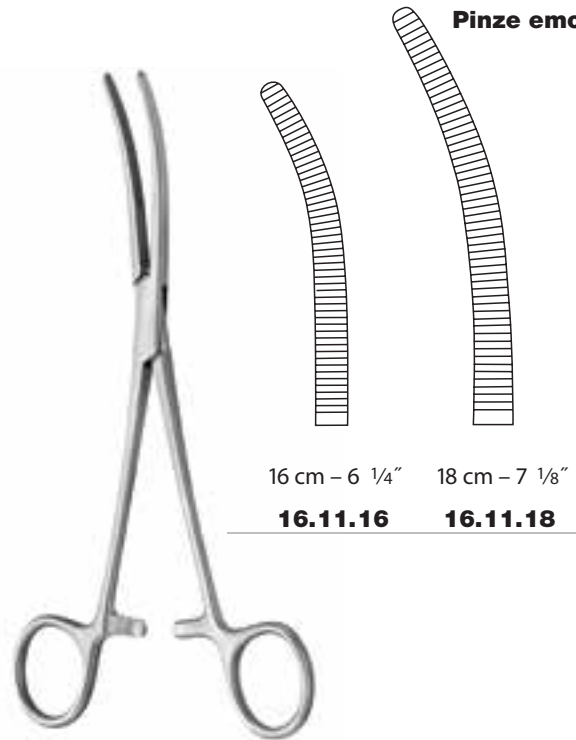

16 cm – 6 1/4" 18 cm – 7 1/8"
16.11.16 16.11.18

Rochester-Pean

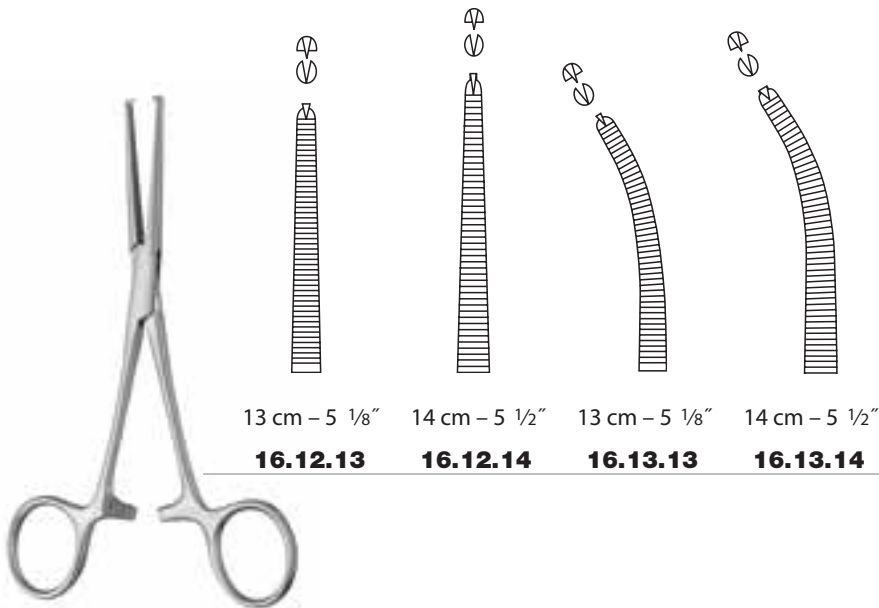

13 cm – 5 1/8" 14 cm – 5 1/2" 13 cm – 5 1/8" 14 cm – 5 1/2"
16.12.13 16.12.14 16.13.13 16.13.14

Kocher



TREVALLi

Arterienklemmen
Hemostatic Forceps
Pinzas hemostáticas
Pinces hémostatiques
Pinze emostatiche

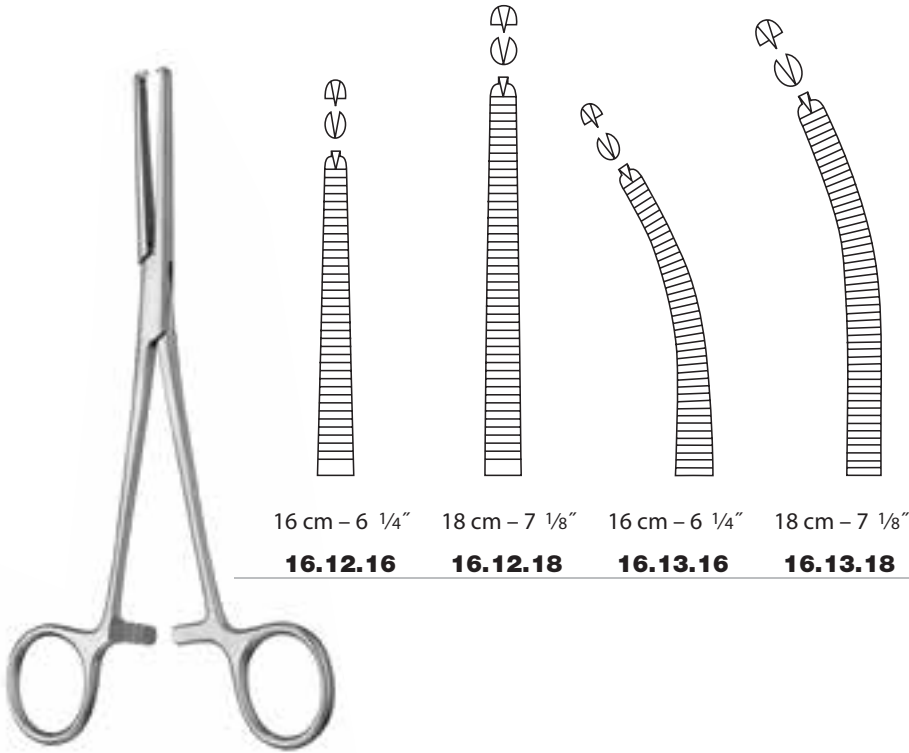

16 cm – 6 ¼"	18 cm – 7 ⅛"	16 cm – 6 ¼"	18 cm – 7 ⅛"
16.12.16	16.12.18	16.13.16	16.13.18

Rochester-Ochsner

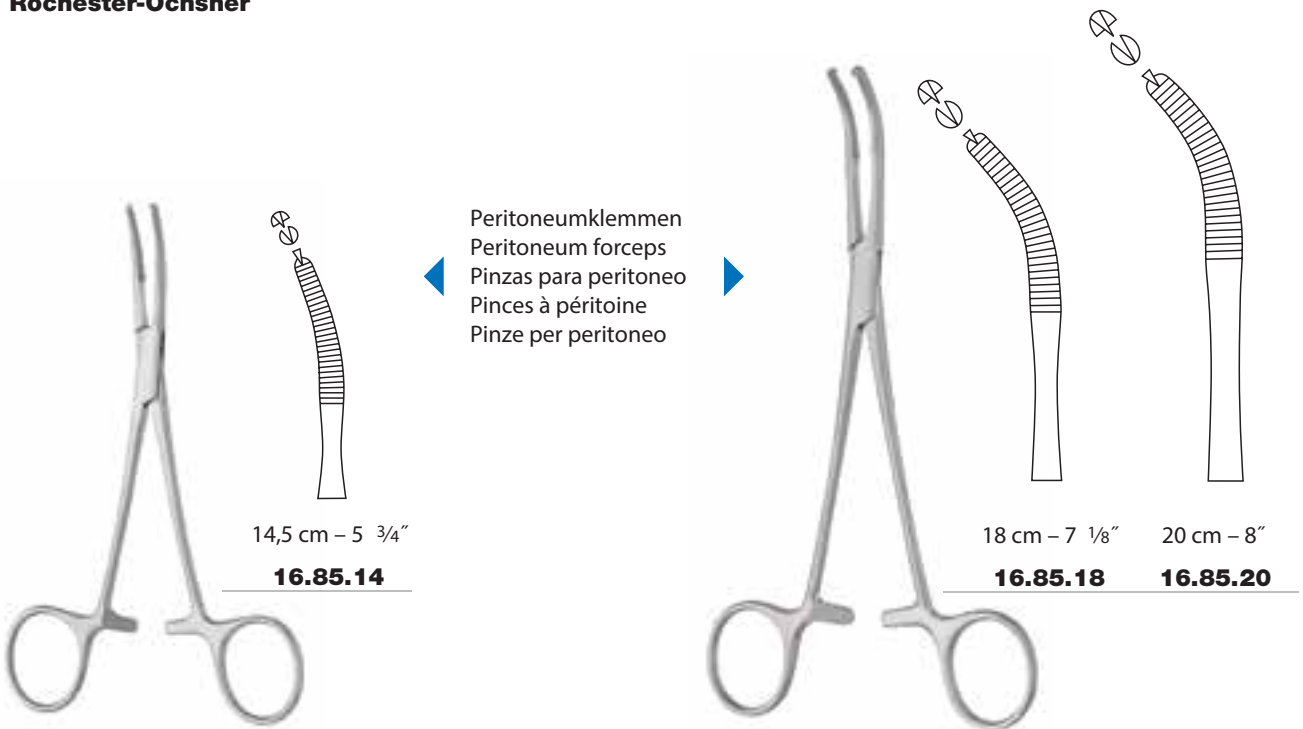

Peritoneumklemmen
Peritoneum forceps
Pinzas para peritoneo
Pinces à péritoine
Pinze per peritoneo

14,5 cm – 5 ¾"
16.85.14

18 cm – 7 ⅛" 20 cm – 8"
16.85.18 **16.85.20**

Mikulicz-Baby

Mikulicz

**Arterienklemmen
Hemostatic Forceps
Pinzas hemostáticas
Pinces hémostatiques
Pinze emostatiche**

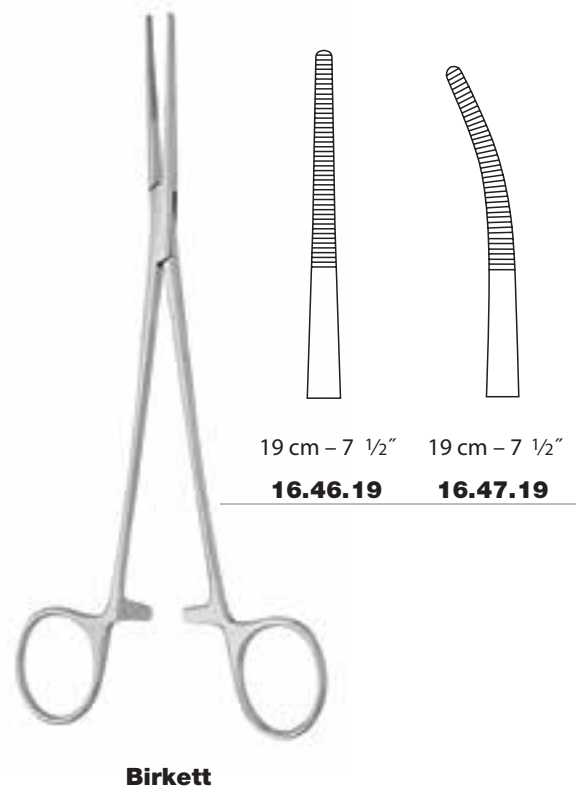
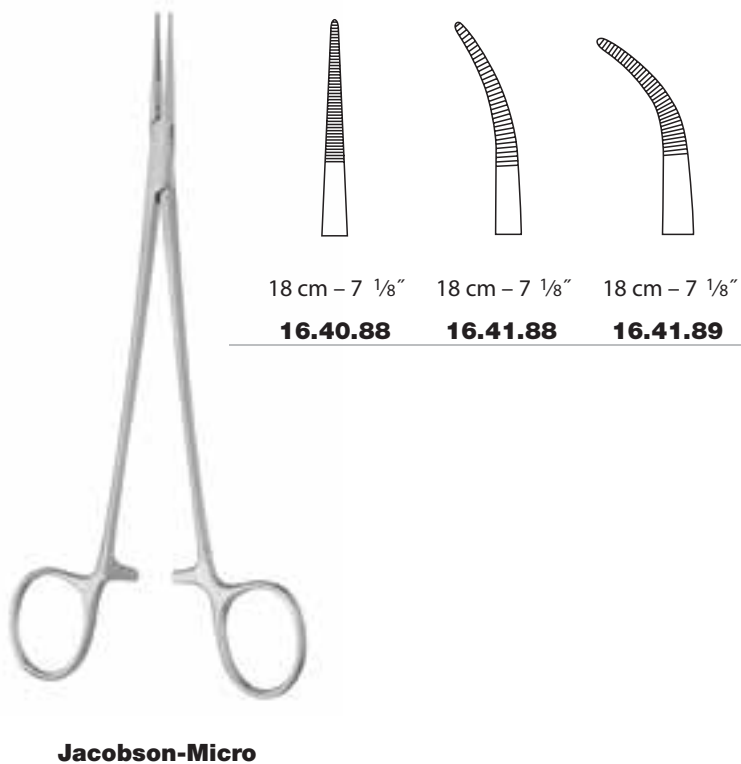
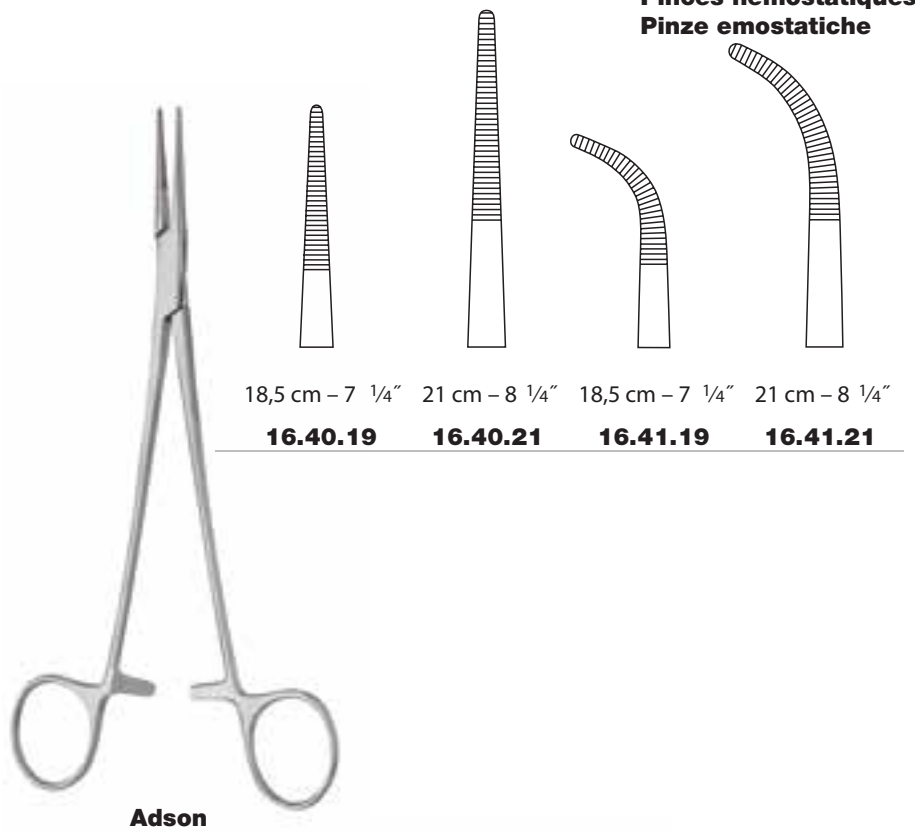
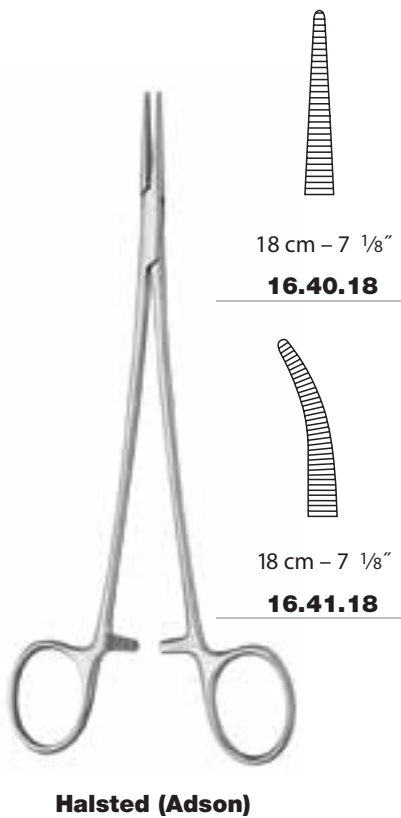



TREVALLi

Präparierklemmen
Dissecting Forceps
Pinzas para disección
Pinces à dissection
Pinze per dissezione



14 cm - 5 1/2"
17.02.14



14 cm - 5 1/2" 19 cm - 7 1/2"
17.05.14 17.05.19

Adson-Baby



14 cm - 5 1/2" 19 cm - 7 1/2"
17.06.14 17.06.19

Mixer-Baby



TREVALLi

**Präparierklemmen
Dissecting Forceps
Pinzas para disección
Pinces à dissection
Pinze per dissezione**



20 cm – 8"

17.07.70

Wikstroem

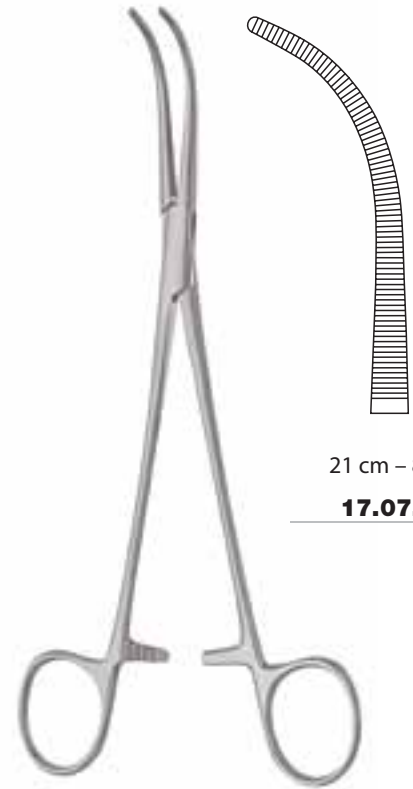

21 cm – 8 1/4"

17.07.60

Overholt-Mixer



25 cm – 10"

17.07.75

27 cm – 10 1/4"

17.07.77

Mixer-Crafoord



TREVALLI



Präparierklemmen
Dissecting Forceps
Pinzas para disección
Pinces à dissection
Pinze per dissezione



Gemini

14 cm – 5 1/2"	18 cm – 7 1/8"	21 cm – 8 1/4"	23 cm – 9"	27 cm – 10 3/4"
17.08.14	17.08.18	17.08.20	17.08.23	17.08.27



TREVALLI • Präparierklemmen
Dissecting Forceps
Pinzas para disección
Pinces à dissection
Pinze per dissezione

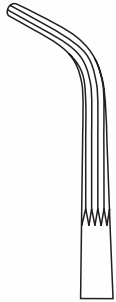

19 cm – 7 1/2"

17.10.19

Lahey-Sweet



19 cm – 7 1/2"

17.11.19

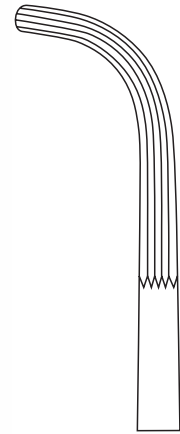

23 cm – 9"

17.11.23

Lahey

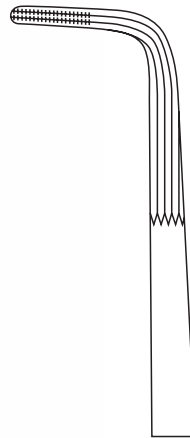

25 cm – 10"

17.12.25

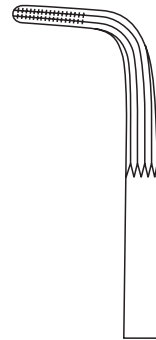

22 cm – 8 3/4"

17.12.22

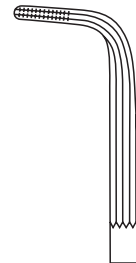

19 cm – 7 1/2"

17.12.19

27 cm – 10 3/4"

17.12.27

29 cm – 11 3/8"

17.12.29

Mixer



TREVALLi

Gewebefasszangen
Tissue Grasping Forceps
Pinzas para agarrar tejidos
Pinces pour saisir le tissu
Pinze per afferrare tessuti



14 cm – 5 1/2"

17.30.14

Chaput

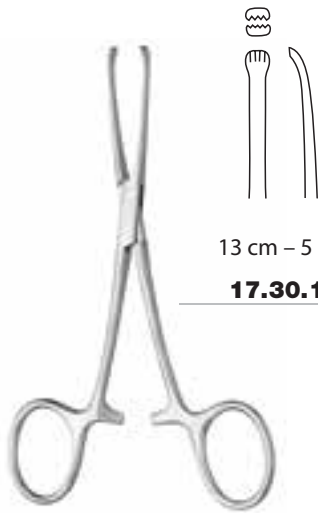

13 cm – 5 1/8"

17.30.15

Tuffier

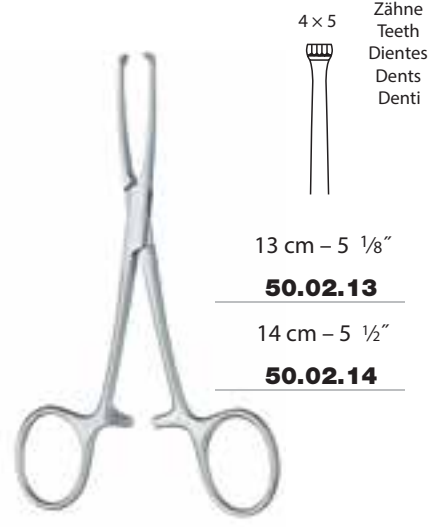

4 x 5
Zähne
Teeth
Dientes
Dents
Denti

13 cm – 5 1/8"

50.02.13

14 cm – 5 1/2"

50.02.14

Allis-Baby

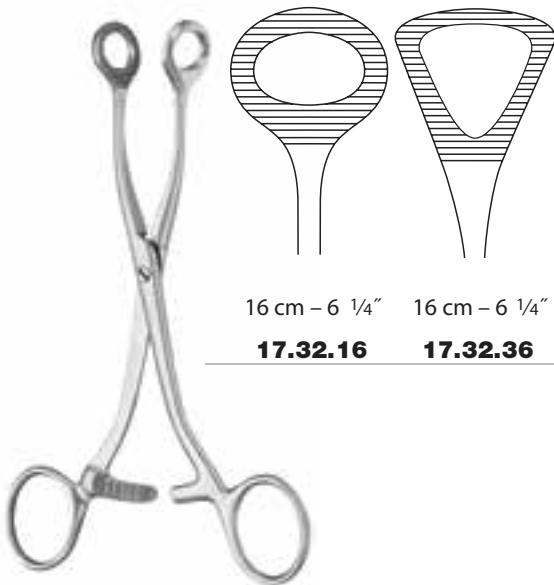

16 cm – 6 1/4"

17.32.16

16 cm – 6 1/4"

17.32.36

Collin

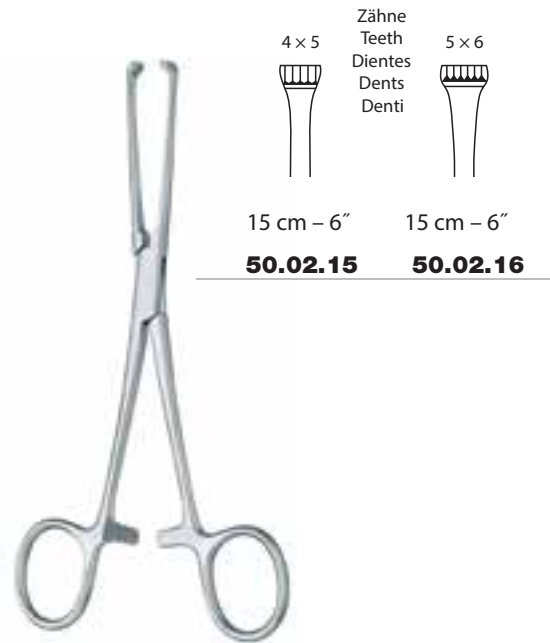

4 x 5
Zähne
Teeth
Dientes
Dents
Denti

15 cm – 6"

50.02.15

5 x 6

15 cm – 6"

50.02.16

Allis



TREVALLI

Hakenzangen, Tuchklemmen
Tenaculum Forceps, Towel Clamps
Pinzas para cuello uterino, Pinzas de campo
Pinces pour le col de l'utérus, Pincers à champs
Pinze per il collo dell'utero, Pinze fissateli



Braun



Czerny



17.50.05



Jones



Schaedel



engl. Mod.



TREVALLi

Tuchklemmen
Towel Clamps
Pinzas de campo
Pinces à champs
Pinze fissateli

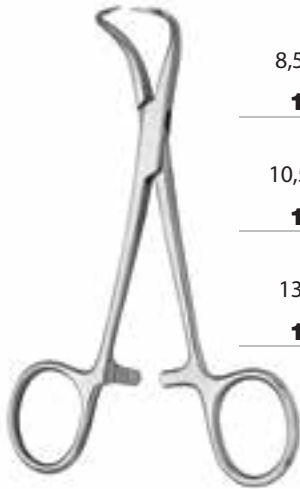

8,5 cm – 3 3/8"

17.55.08

10,5 cm – 4 1/8"

17.55.10

13 cm – 5 1/8"

17.55.13

Backhaus



15 cm – 6"

17.55.15

Backhaus

Ball and Socket



11 cm – 4 3/8"

17.55.20

13 cm – 5 1/8"

17.55.23

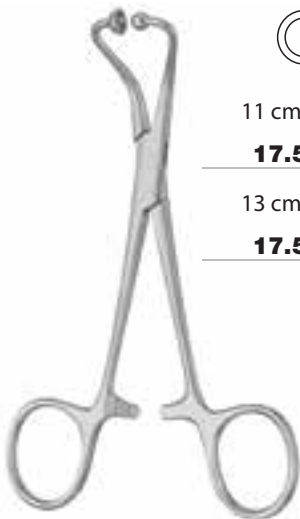

Backhaus



13 cm – 5 1/8"

17.57.83



Medicon

für Schlauch-Ø bis 15 mm
for tubes Ø up to 15 mm
para tubos hasta Ø 15 mm
pour tuyaus jusqu'à Ø 15 mm
per tubi fino a Ø di 15 mm

10 cm – 4"

17.65.10



Backhaus



TREVALLi

Schlauchklemmen
Tubing Clamps
Pinzas cierra-tubos
Pinces presse-tube
Pinze serratubi



15,5 cm – 6 1/8" 18 cm – 7 1/8" 20 cm – 8"
17.72.75 17.72.78 17.72.80

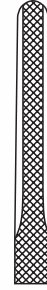

15,5 cm – 6 1/8" 18 cm – 7 1/8" 20 cm – 8"
17.72.76 17.72.79 17.72.81

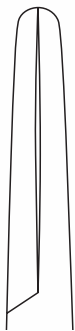

16 cm – 6 1/4" 18 cm – 7 1/8" 20 cm – 8"
17.72.16 17.72.18 17.72.20



14,5 cm – 5 3/4"
17.73.14

Presbyterian-Hospital



TREVALLi

Kornzangen
Dressing Forceps
Pinzas para curaciones
Pinces à pansements
Pinze per medicazione



13 cm – 5 1/8"

19.06.13



15 cm – 6"

19.06.15



18 cm – 7 1/8"

19.06.18

Lister



17,5 cm – 7"

19.09.17



20 cm – 8"

19.16.20



20 cm – 8"

19.17.20

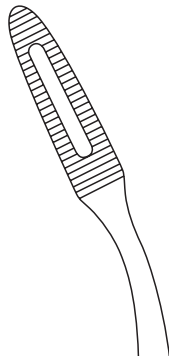

Gross

26 cm – 10 1/4" 26 cm – 10 1/4"

19.16.26

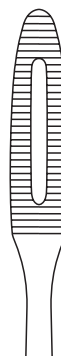

19.17.26

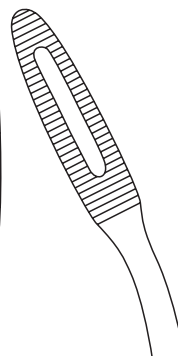

Maier



TREVALLi

Tupferzangen
Cotton Swab Forceps
Pinzas porta-tapones
Pinces porte-tampons
Pinze per tamponamento



Ulrich

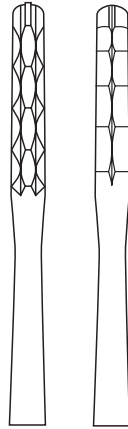

18 cm - 7 1/8"

19.40.18

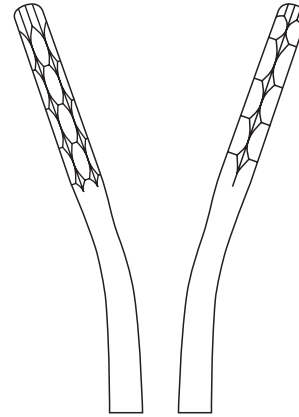

18 cm - 7 1/8"

19.41.18

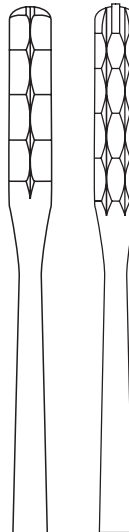

20 cm - 8"

19.40.20

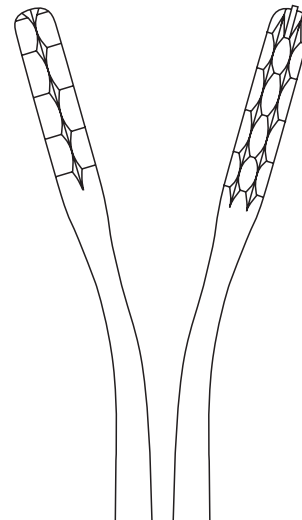

20 cm - 8"

19.41.20

22 cm - 8 3/4"

19.40.22

22 cm - 8 3/4"

19.41.22

26 cm - 10 1/4"

19.40.26

26 cm - 10 1/4"

19.41.26



TREVALLi

Schwammzangen
Sponge Forceps
Pinzas porta-esponjas
Pinces à pansements
Pinze per spugne



Foerster

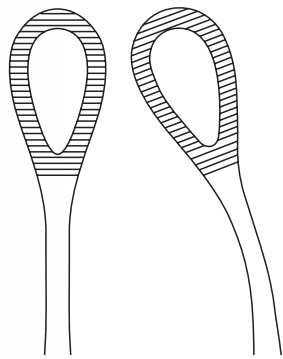

18 cm – 7 1/8" 18 cm – 7 1/8"
19.50.18 19.51.18



Foerster

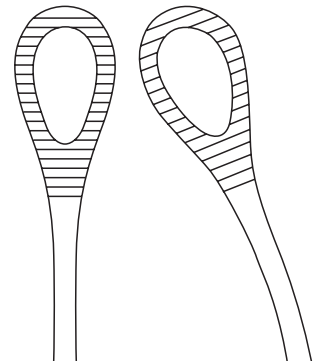

20 cm – 8" 20 cm – 8"
19.50.20 19.51.20

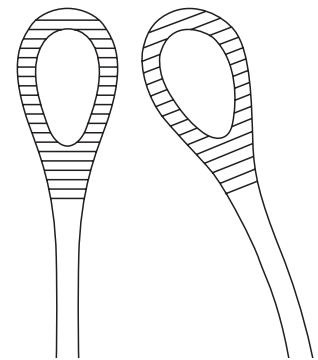

24 cm – 9 1/2" 24 cm – 9 1/2"
19.50.24 19.51.24



TREVALLi

Knochenfeilen
Bone Files
Limas para huesos
Limes à os
Lime per ossa



Joseph

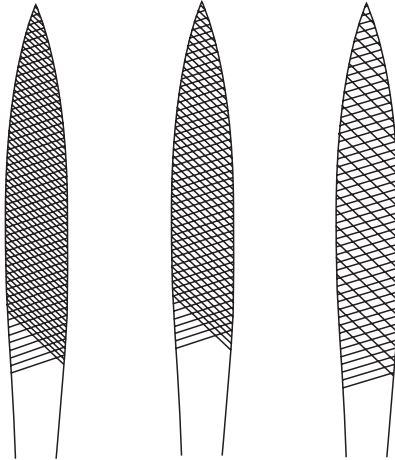

17 cm – 6 3/4"	17 cm – 6 3/4"	17 cm – 6 3/4"
26.05.21	26.05.22	26.05.23
# 1	# 2	# 3



Gallaher

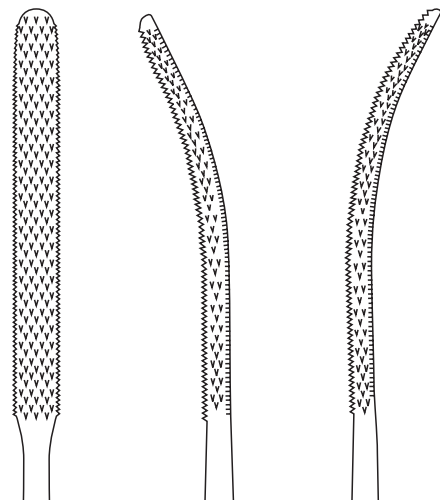

19 cm – 7 1/2"	19 cm – 7 1/2"	19 cm – 7 1/2"
26.05.41	26.05.42	26.05.43
# 1	# 2	# 3



TREVALLi

Knochenfeilen
Bone Files
Limas para huesos
Limes à os
Lime per ossa



Miller

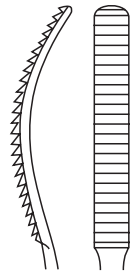

18 cm - 7 1/8"

26.10.10

10

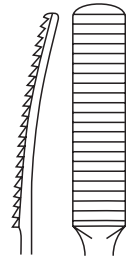

18 cm - 7 1/8"

26.10.11

11

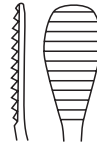

18 cm - 7 1/8"

26.10.12

12



18 cm - 7 1/8"

26.10.13

13

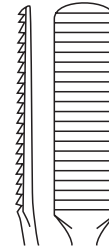

18 cm - 7 1/8"

26.10.14

14

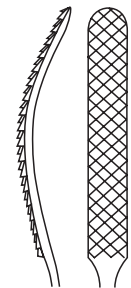
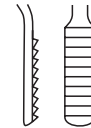
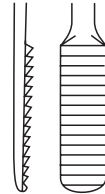
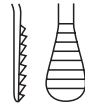

18 cm - 7 1/8"

26.10.20

10C

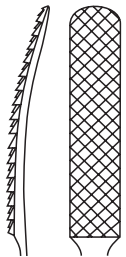

18 cm - 7 1/8"

26.10.21

11C

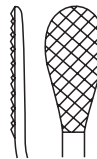

18 cm - 7 1/8"

26.10.22

12C

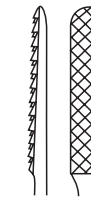

18 cm - 7 1/8"

26.10.23

13C

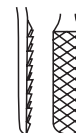
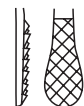
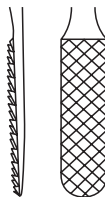

Miller



TREVALLi

**Elevatorien
Elevators
Elevadores
Élévateurs
Elevatori**

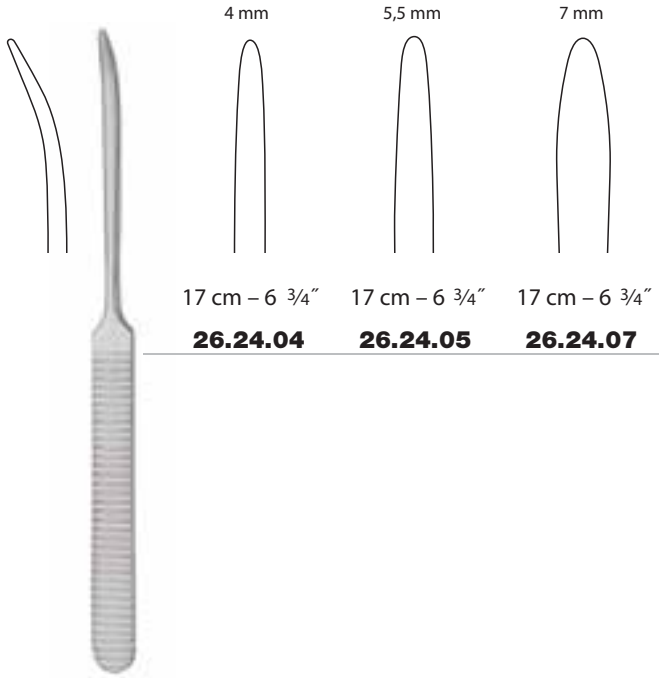

4 mm	5,5 mm	7 mm
17 cm – 6 3/4"	17 cm – 6 3/4"	17 cm – 6 3/4"
26.24.04	26.24.05	26.24.07

Williger

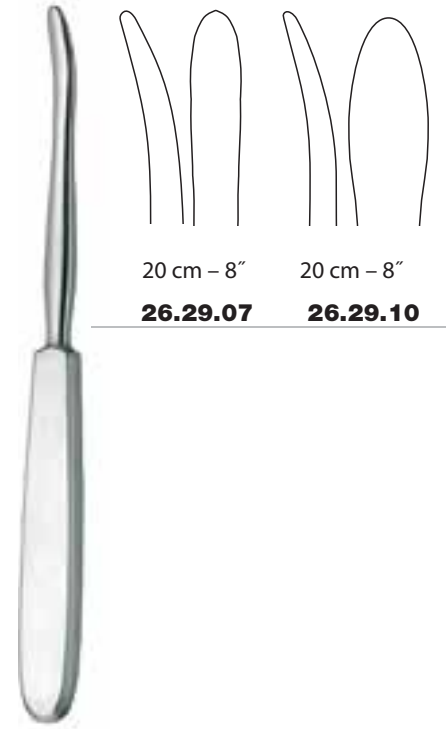

20 cm – 8"	20 cm – 8"
26.29.07	26.29.10

Langenbeck

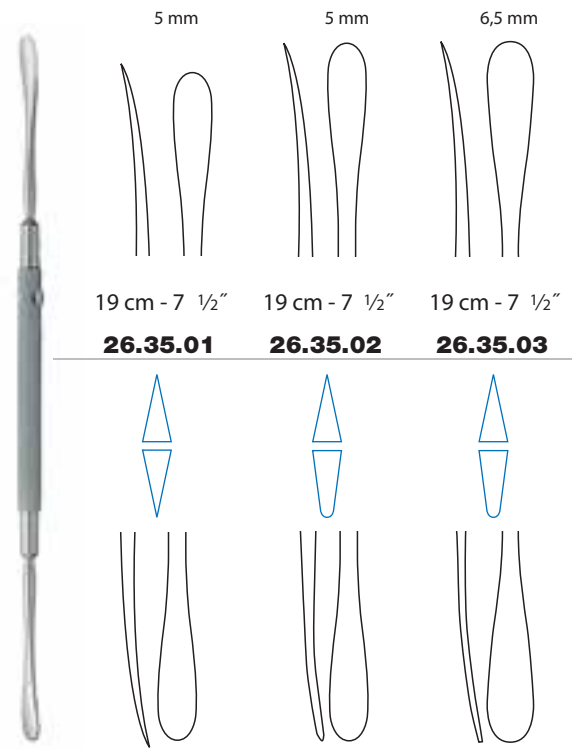

5 mm	5 mm	6,5 mm
19 cm - 7 1/2"	19 cm - 7 1/2"	19 cm - 7 1/2"
26.35.01	26.35.02	26.35.03

Freer

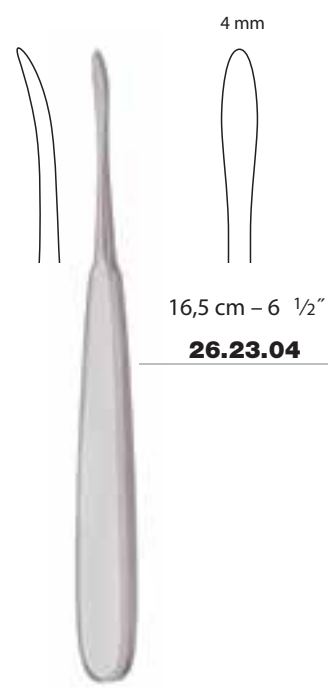

4 mm
16,5 cm – 6 1/2"
26.23.04

Sebileau

scharf
sharp
cortante
tranchant

stumpf
blunt
roma
mousse



TREVALLi

**Elevatorien, Raspatorien
Elevators, Raspatories
Elevadores, Legras
Elévateurs, Rugines
Elevatori, Periostotomi**

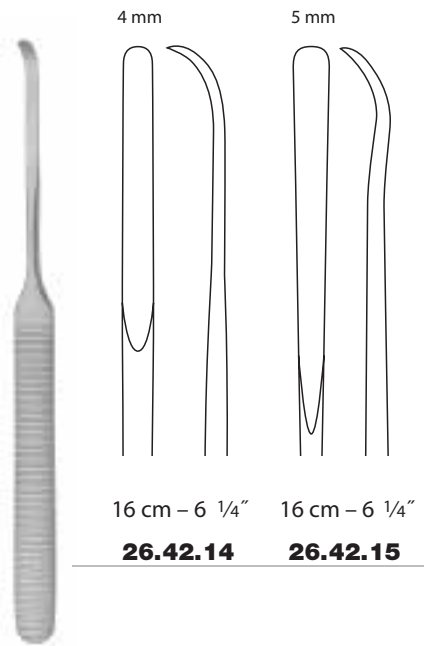

Kahre-Williger

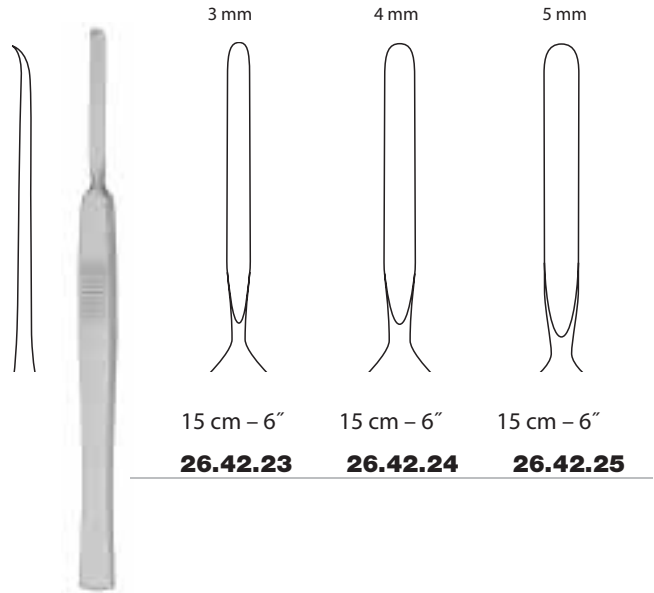

McKenty



Bennet

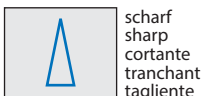

scharf
sharp
cortante
tranchant
tagliente



Stiller



stumpf
blunt
roma
mousse
smussa

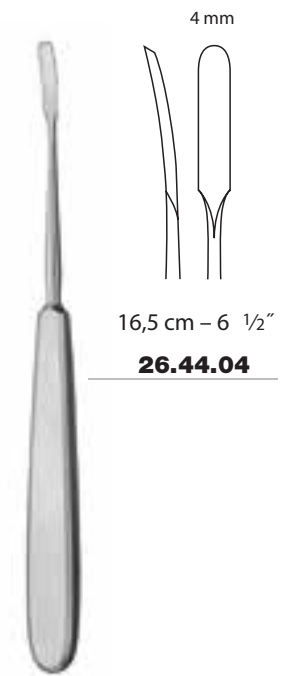

Joseph



TREVALLi

Raspatorien
Raspatories
Legras
Rugines
Periostotomi



Lucas

◀ Knochenküretten
Bone curettes
Cucharillas óseas
Curettes à os
Cucchiai ossivori ▶

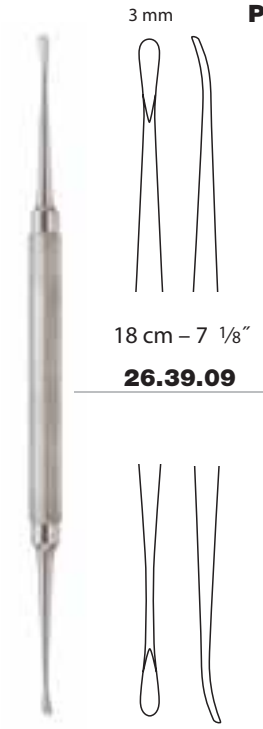

Miller

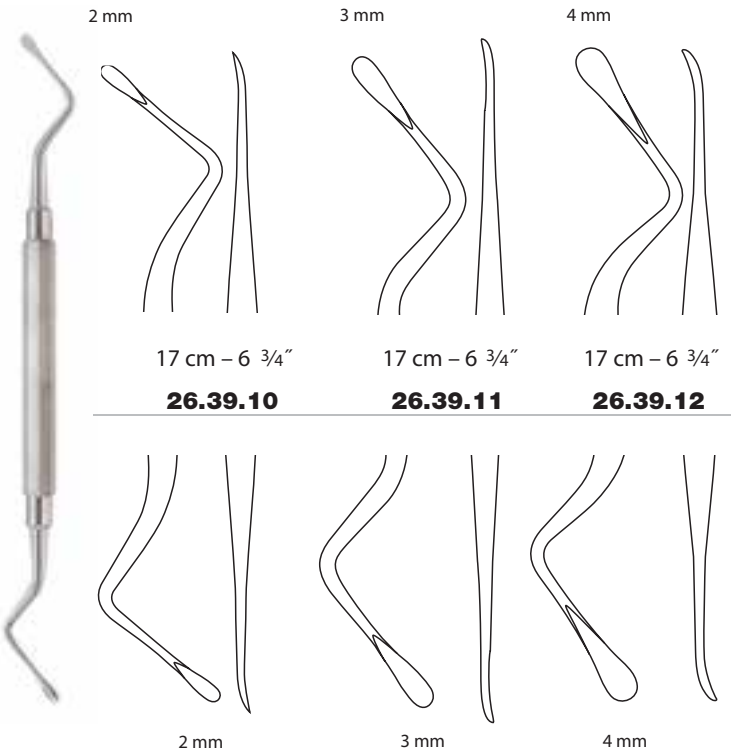









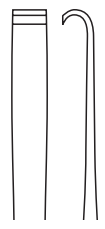





Miller





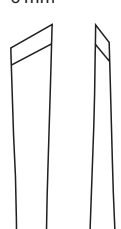

TREVALLi

Raspatorien
Raspatories
Legras
Rugines
Periostotomi

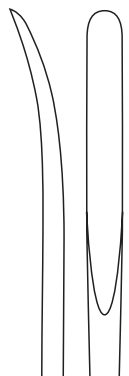
	5 mm	6 mm	7 mm	7 mm	
					
	18 cm - 7 1/8"	18 cm - 7 1/8"	18 cm - 7 1/8"	18 cm - 7 1/8"	
	26.37.01	26.37.02	26.37.03	26.37.07	
					
					
Molt	4 mm	5 mm	4 mm	4 mm	

	6 mm
	
	16,5 cm - 6 1/2"
	26.37.10
	
	
Mead	5 mm

	5 mm
	
	15 cm - 6"
	26.40.06
König	

	3 mm	5 mm	7 mm
			
	16 cm - 6 1/4"	16 cm - 6 1/4"	16 cm - 6 1/4"
	26.42.03	26.42.05	26.42.07
Williger			

 scharf
sharp
cortante
tranchant
tagliente

 stumpf
blunt
roma
mousse
smussa



TREVALLi

**Raspatorien, Anthelix-Knorpelfeilen für die Ohrmuschelplastik
Raspatories, Anthelix Cartilage Files for Auricular Plastic
Legras, Limas para el cartilago del anthelix para la otoplastia
Rugines, Limes pour le cartilage de l'anthélix pour l'otoplastie
Periostotomi, Lime per cartilagine del anthelix per l'otoplastica**



Lempert

2 mm



17 cm - 6 3/4"

26.44.22

3 mm

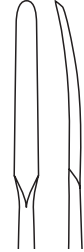

17 cm - 6 3/4"

26.44.23

4 mm



17 cm - 6 3/4"

26.44.24

5 mm



17 cm - 6 3/4"

26.44.25

3,5 mm



17 cm - 6 3/4"

26.44.28

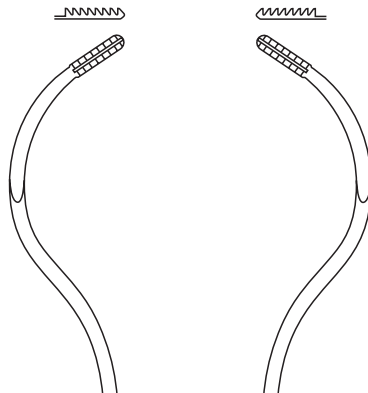

16 cm - 6 1/4"

67.99.98

16 cm - 6 1/4"

67.99.99

Kistler

12 mm

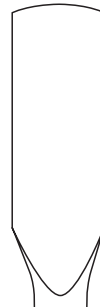

Farabeuf



15 cm - 6"

26.53.13



15 cm - 6"

26.53.23

Die Zahnung (Abstand = 1 mm) ist auf Zugwirkung angeordnet. Eine Längsriefung (0,5 mm) teilt diese in zwei parallel stehende Zahnreihen. Die Knorpelhaul wird dadurch ausreichend eingeritzt.

The toothing (1 mm interval) is designed to exert a traction force. A longitudinal channel (0.5 mm) divides it into two parallel rows of teeth. This ensures that the perichondrium is sufficiently scratched.

El dentado (distancia = 1 mm) está dispuesto sobre un efecto tractor. Un estriado longitudinal (0,5 mm) lo divide en dos filas dentadas paralelas. El pericondrio se entalla de este modo suficientemente.

La denture (écart 1 mm) est disposée de manière à inciser lorsqu'une traction est exercée sur l'instrument. Une rainure longitudinale (0,5 mm) sépare la denture en deux dentures parallèles, ce qui permet d'entailler la peau qui recouvre le cartilage.

La dentellatura (distanza = 1 mm) è predisposta per la trazione. Una scanalatura longitudinale (0,5 mm) la divide in due righe di denti paralleli. Ciò consente di incidere a sufficienza la cartilagine.



TREVALLi

Hämmer
Mallets
Martillos
Maillets
Martelli

Ø 30 mm



21 cm – 8 1/4"

27.04.22

220 g

Collin (Lucae)

mit Kunststoffbacken
(abschraubbar)

with plastic facings
(unscrewable)

con frenes de plástico
(destornillables)

avec joues en matière plastique
(dévissables)

con guancie di plastica
(svitabili)

Ø 25 mm

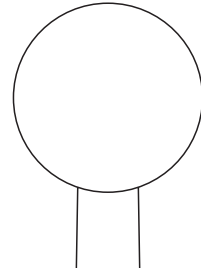

18,5 cm - 7 1/4"

27.06.20

200 g

27.06.21

Ersatzbacken, Paar
Spare facings, pair
Frenes de repuesto, par
Joues de rechange, paire
Guancie di ricambio, paio

Ø 20 mm



16,5 cm – 6 1/2" 16,5 cm – 6 1/2"

27.02.10

27.02.13

100 g

130 g

massiv
solid head
macizo
massif
massiccio

bleigefüllt
lead filled head
relleno de plomo
rempli de plomb
pieno di piombo

Ø 26 mm



21 cm – 8 1/4"

27.04.20

200 g

Hajek



TREVALLi

Flachmeißel
Chisels
Cinceles
Ciseaux burins
Scalpelli

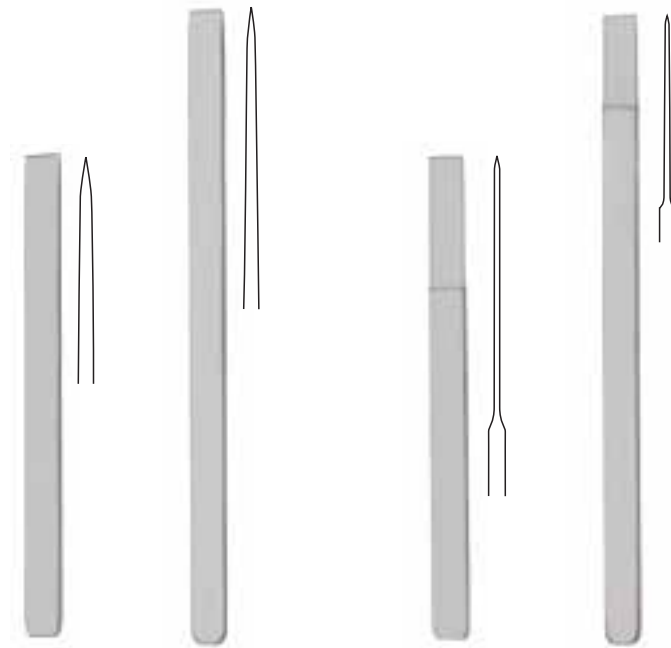

Mini-Lambotte

Hardt-Delima

	13 cm – 5 1/8"	17 cm – 6 3/4"	13 cm – 5 1/8"	17 cm – 6 3/4"
2 mm	27.57.02	27.57.52	27.58.02	27.58.52
4 mm	27.57.04	27.57.54	27.58.04	27.58.54
6 mm	27.57.06	27.57.56	27.58.06	27.58.56
8 mm	27.57.08	27.57.58	27.58.08	27.58.58
10 mm	27.57.10	27.57.60	27.58.10	27.58.60
12 mm	27.57.12	27.57.62	27.58.12	27.58.62
15 mm	27.57.15	27.57.65	27.58.15	27.58.65
	27.57.90	27.57.95	27.58.90	27.58.95



Satz komplett in Segeltuchetui
Set complete in canvas roll
Juego completo en bolsa de lona
Série complète en housse de toile
Serie completa in custodia di tela



TREVALLi

Flach- und Hohlmeißel
Chisels and Gouges
Cinceles y gubias
Ciseaux burins et gouges
Scalpelli e sgorbie

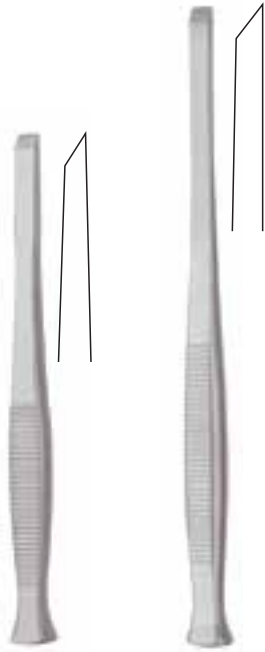

Partsch

14 cm – 5 1/2" 17 cm – 6 3/4"

2 mm	27.61.02	27.61.12	27.61.62	27.61.72
3 mm	27.61.03	27.61.13	27.61.63	27.61.73
4 mm	27.61.04	27.61.14	27.61.64	27.61.74
6 mm	27.61.06	27.61.16	27.61.66	27.61.76
8 mm	27.61.08	27.61.18	27.61.68	27.61.78

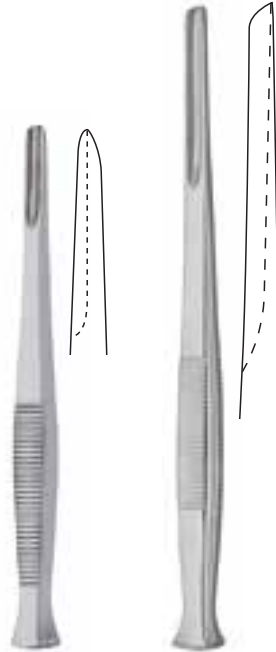

Partsch

14 cm – 5 1/2" 17 cm – 6 3/4"

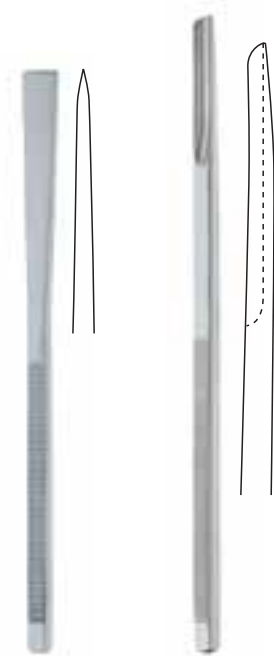

Sheehan

16 cm – 6 1/4" 16 cm – 6 1/4"

2 mm	27.62.02	27.62.62
3 mm		27.62.63
4 mm	27.62.04	27.62.64
6 mm	27.62.06	27.62.66
8 mm	27.62.08	
10 mm	27.62.10	
12 mm	27.62.12	
15 mm	27.62.15	
18 mm	27.62.18	
20 mm	27.62.20	



TREVALLI

Flach- und Hohlmeißel, Knochenstopfer
Chisels and Gouges, Bone tampers
Cinceles y gubias, Pisón para huesos
Ciseaux burins et gouges, Pousoirs à os
Scalpelli e sgorbie, Impattatori per ossa



18 cm - 7 1/8"

4 mm **27.64.04**

18 cm - 7 1/8"

7 mm **27.64.07**

18 cm - 7 1/8"

9 mm **27.64.09**

18 cm - 7 1/8"

12 mm **27.64.12**



Cottle-Medicon



Ø 3 mm



16 cm - 6 1/4"

27.95.03

Ø 5 mm



16 cm - 6 1/4"

27.95.05

Ø 7 mm



16 cm - 6 1/4"

27.95.07

Ø 9 mm



16 cm - 6 1/4"

27.95.09



4 mm



17 cm - 6 3/4"

27.80.10

4 mm



17 cm - 6 3/4"

27.80.11

4 mm



17 cm - 6 3/4"

27.80.19

Freer



Ø 12 mm



20 cm - 8"

27.95.20

Ø 14 mm

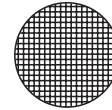

20 cm - 8"

27.95.21

Ø 16 mm

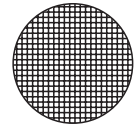

20 cm - 8"

27.95.22

Passow



3 mm

12 cm - 4 3/4"

27.95.11

3,5 mm



12 cm - 4 3/4"

27.95.12



Kunststoffgriff (autoklavierbar bis 134 °C bei 3 bar)
Plastic handle (autoclavable up to 134 °C at 3 bar)
Mango de material plástica (autoclavable hasta 134 °C bajo presión de 3 bar)
Manico di plastica (autoclavabile fino a 134 °C sotto pressione di 3 bar)
Manche en matière plastique (autoclavable à 134 °C sous pression de 3 bars)

Caspar



TREVALLi

Flach- und Hohlmeißel
Chisels and Gouges
Cinceles y gubias
Ciseaux burins et gouges
Scalpelli e sgorbie

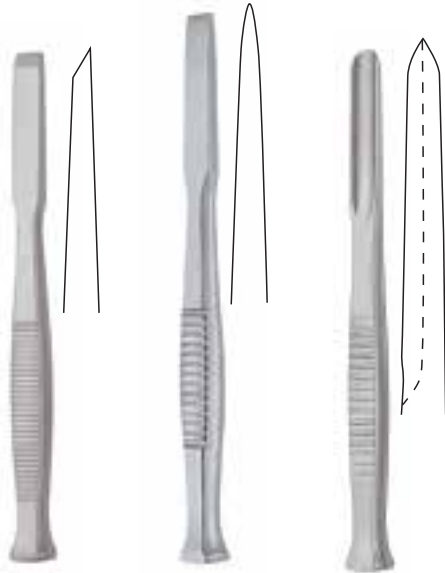

	14 cm – 5 1/2"	14 cm – 5 1/2"	14 cm – 5 1/2"
3 mm		28.05.03	28.06.03
4 mm	28.04.04	28.05.04	28.06.04
5 mm		28.05.05	28.06.05
6 mm	28.04.06	28.05.06	28.06.06
8 mm	28.04.08	28.05.08	28.06.08
10 mm	28.04.10	28.05.10	28.06.10
12 mm	28.04.12	28.05.12	28.06.12

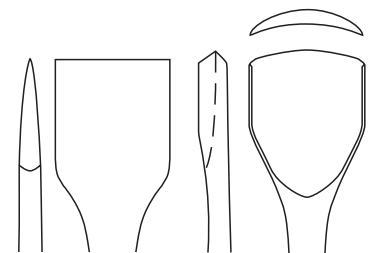

	18 cm – 7 1/8"	18 cm – 7 1/8"
2 mm	28.61.02	28.62.02
4 mm	28.61.04	28.62.04
6 mm	28.61.06	28.62.06
8 mm	28.61.08	28.62.08
10 mm	28.61.10	28.62.10
12 mm	28.61.12	28.62.12
15 mm	28.61.15	28.62.15
20 mm	28.61.20	28.62.20



Mini-Lexer

Kunststoffgriff auch in PROPYLUX erhältlich
 Plastic handle also available in PROPYLUX
 Mango de plástico está disponible también en PROPYLUX
 Manche en matière plastique est également disponible en matière PROPYLUX
 Manico di plastica è disponibile anche in PROPYLUX



TREVALLi

Scharfe Löffel
Sharp Currettes
Cucharillas cortantes
Currettes tranchantes
Cucchiai taglienti

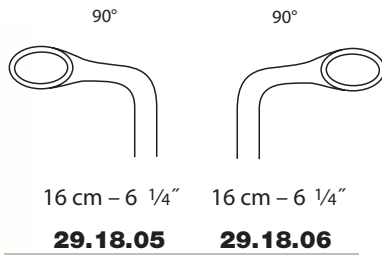

Siebenmann

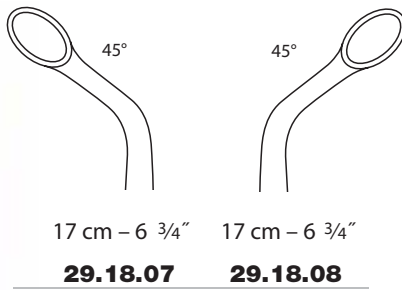
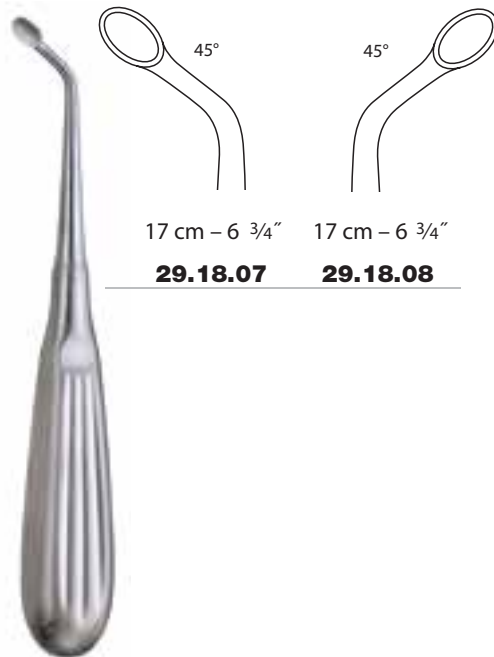

Uffenorde

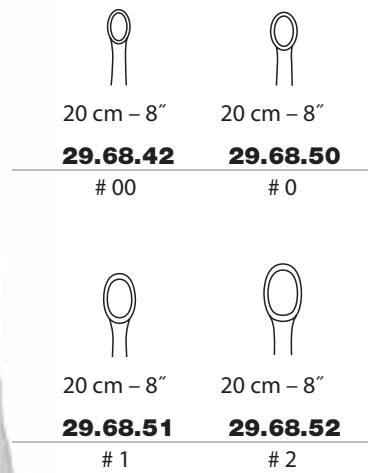
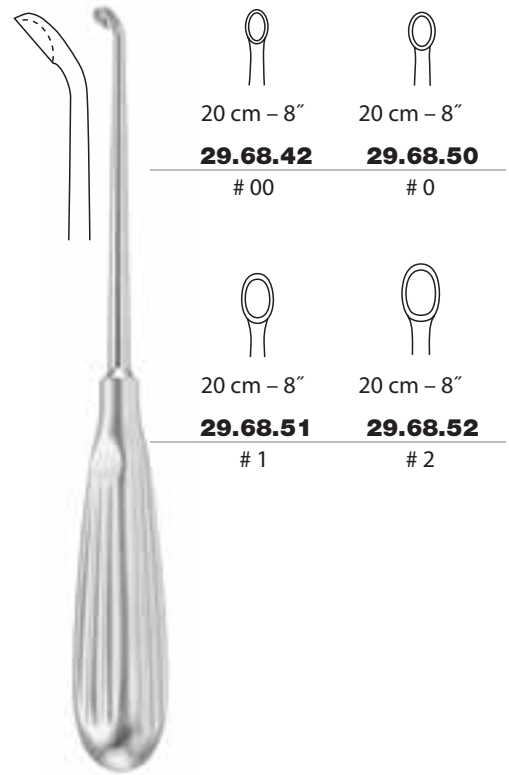

Daubenspeck



TREVALLi

Scharfe Löffel
Sharp Currettes
Cucharillas cortantes
Currettes tranchantes
Cucchiai taglienti



# 0000	# 000	# 00	# 0	# 1
17 cm – 6 3/4"	17 cm – 6 3/4"	17 cm – 6 3/4"	17 cm – 6 3/4"	17 cm – 6 3/4"
29.51.24	29.51.33	29.51.42	29.51.50	29.51.51

# 2	# 3	# 4	# 5	# 6
17 cm – 6 3/4"	17 cm – 6 3/4"	17 cm – 6 3/4"	17 cm – 6 3/4"	17 cm – 6 3/4"
29.51.52	29.51.53	29.51.54	29.51.55	29.51.56

Volkman



# 000	# 00	# 0	# 1	# 2
17 cm – 6 3/4"	17 cm – 6 3/4"	17 cm – 6 3/4"	17 cm – 6 3/4"	17 cm – 6 3/4"
29.40.33	29.40.42	29.40.50	29.40.51	29.40.52

# 3	# 4	# 5	# 6
17 cm – 6 3/4"	17 cm – 6 3/4"	17 cm – 6 3/4"	17 cm – 6 3/4"
29.40.53	29.40.54	29.40.55	29.40.56

Bruns



TREVALLI

Scharfe Löffel
Sharp Currettes
Cucharillas cortantes
Currettes tranchantes
Cucchiai taglienti



Williger

Ø 4 mm



17 cm – 6 ¾"

29.24.01

1

Ø 5 mm



17 cm – 6 ¾"

29.24.02

2

3,5 mm



17 cm – 6 ¾"

29.24.51

1

5,5 mm



17 cm – 6 ¾"

29.24.52

2



Lempert

1 mm



21 cm – 8 ¼"

29.67.06

000000

1,5 mm



21 cm – 8 ¼"

29.67.15

00000

2 mm



21 cm – 8 ¼"

29.67.24

0000

2,2 mm



21 cm – 8 ¼"

29.67.33

000

2,5 mm



21 cm – 8 ¼"

29.67.42

00

2,7 mm



21 cm – 8 ¼"

29.67.50

0

3,0 mm



21 cm – 8 ¼"

29.67.51

1

3,3 mm



21 cm – 8 ¼"

29.67.52

2



biegsam
malleable
maleable
malléable
malleabile

Halle

4 mm



21 cm – 8 ¼"

29.69.51

1

5 mm



21 cm – 8 ¼"

29.69.52

2

6 mm



21 cm – 8 ¼"

29.69.53







3





TREVALLi

Scharfe Löffel
Sharp Curettes
Cucharillas cortantes
Curettes tranchantes
Cucchiai taglienti







Martini

		
2,5 mm	3 mm	4 mm
14 cm – 5 1/2"	14 cm – 5 1/2"	14 cm – 5 1/2"
29.80.10	29.80.11	29.80.12
# 00-0	# 0-1	# 1-2
		
3 mm	4 mm	5 mm

Jansen

	
	Ø 3 mm
	17 cm – 6 3/4"
	29.80.62
	
	Ø 5 mm

Williger

		
2 mm	2,5 mm	3 mm
14 cm – 5 1/2"	14 cm – 5 1/2"	14 cm – 5 1/2"
29.83.10	29.83.11	29.83.12
# 00-0	# 0-1	# 1-2
		
2,5 mm	3 mm	4 mm



TREVALLi

**Hohlmeißelzangen
Bone Rongeurs
Pinzas gubias
Pinces-gouges
Pinze sgorbie**



14 cm - 5 1/2"
30.05.14

Friedmann



14 cm - 5 1/2"
30.07.14

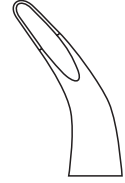

14 cm - 5 1/2"
30.07.15



14 cm - 5 1/2"
30.17.14
1



17 cm - 6 3/4"
30.17.17
1A

Mead



16 cm - 6 1/4"
30.38.56

Hartmann



TREVALLI

Hohlmeißelzangen
Bone Rongeurs
Pinzas gubias
Pinces-gouges
Pinze sgorbie

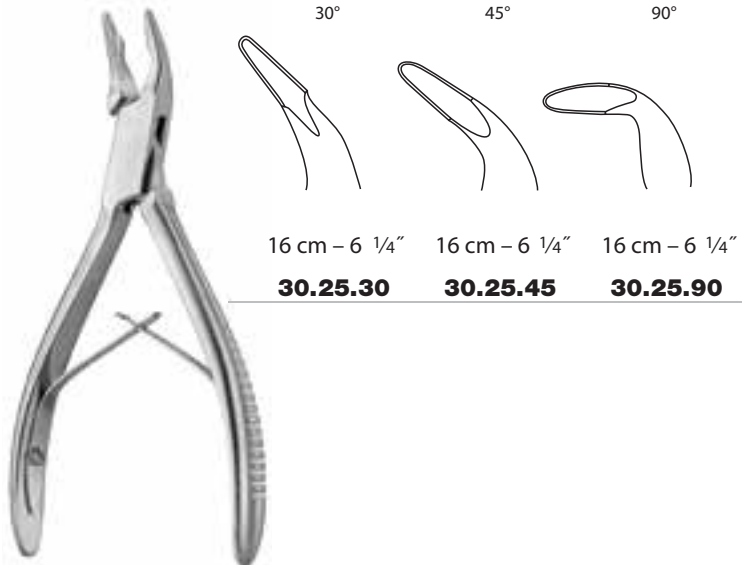

Blumenthal



Luer

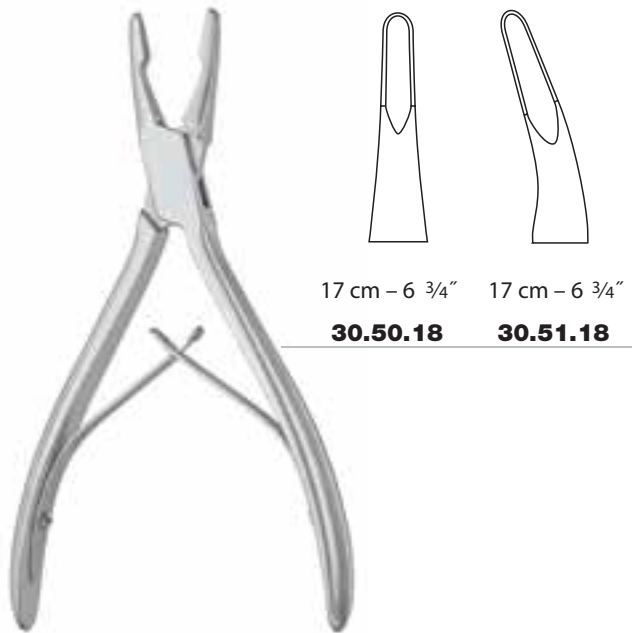

Jansen

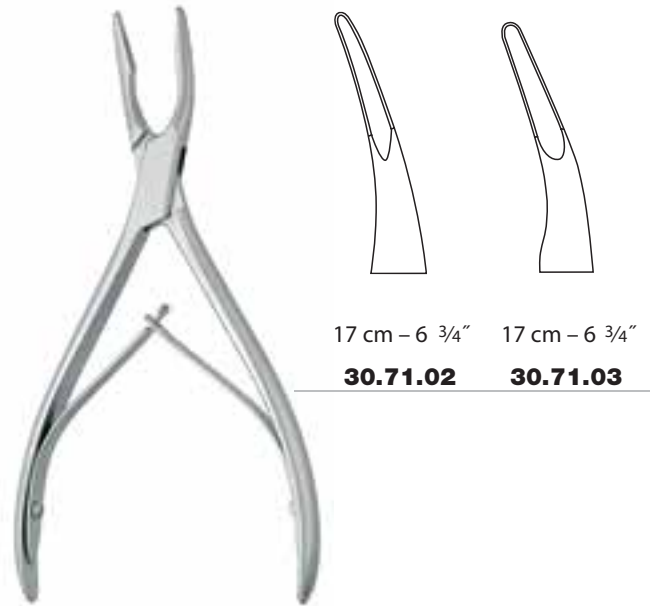

Beyer



TREVALLi

Hohlmeißelzangen
Bone Rongeurs
Pinzas gubias
Pinces-gouges
Pinze sgorbie



14 cm – 5 1/2"

30.76.13

14 cm – 5 1/2"

30.76.14

Kleinert-Kutz



19 cm – 7 1/2"

30.79.19

Defourmentel



17 cm – 6 3/4"

30.76.17

17 cm – 6 3/4"

30.76.18

Stellbrink

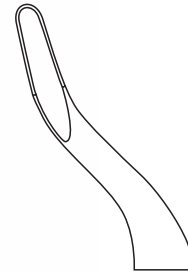

17 cm – 6 3/4"

30.79.59

Jansen



TREVALLi

Hohlmeißelzangen
Bone Rongeurs
Pinzas gubias
Pinces-gouges
Pinze sgorbie



Ruskin-Mini



15 cm – 6"

31.04.02



15 cm – 6"

31.04.03



Ruskin-Mini



15 cm – 6"

31.05.02



15 cm – 6"

31.05.03



Lempert



19 cm – 7 1/2"

30.76.19



19 cm – 7 1/2"

30.76.29



TREVALLi

Hohlmeißelzangen
Bone Rongeurs
Pinzas gubias
Pinces-gouges
Pinze sgorbie



18 cm - 7 1/8"

31.11.04

Beyer



18 cm - 7 1/8"

31.11.05

Zaufal-Jansen



18 cm - 7 1/8"

31.07.65

Ruskin



18 cm - 7 1/8"

31.06.05

18 cm - 7 1/8"

31.07.05

Ruskin



TREVALLi

**Knochensplitterzangen
Bone Cutting Forceps
Pinzas cortantes para huesos
Pinces coupantes à os
Pinze ossivore**



15 cm - 6"

33.02.15

Littauer



18 cm - 7 1/8"

33.04.18

Cottle-Kazanjian

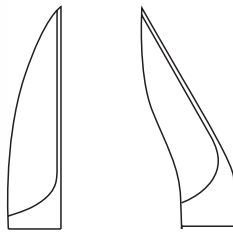

18 cm - 7 1/8"

33.56.18

18 cm - 7 1/8"

33.57.18

Ruskin-Liston



18 cm - 7 1/8"

33.59.17

McIndoe



TREVALLi

Knochensplitterzangen
Bone Cutting Forceps
Pinzas cortantes para huesos
Pinces coupantes à os
Pinze ossivore



Liston-mini



15 cm - 6"
33.50.15



15 cm - 6"
33.51.15



Liston



14 cm - 5 1/2"
33.20.14



17 cm - 6 3/4"
33.20.17



19 cm - 7 1/2"
33.20.19



22 cm - 8 3/4"
33.20.22



Liston



14 cm - 5 1/2"
33.21.14



17 cm - 6 3/4"
33.21.17



19 cm - 7 1/2"
33.21.19



22 cm - 8 3/4"
33.21.22



TREVALLI

**Messinstrumente
Measuring Instruments
Instrumentos de medida
Instruments de mesure
Strumenti per misurazione**

graduiert in mm und Zoll
graduated in mm and inches
graduado en mm y pulgadas
graduée en mm et pouces
graduate in mm e pollici



Stahllineale, rostfrei
Rulers, stainless steel
Reglas de acero, inoxidable
Règles en acier inoxydable
Righe in acciaio, inossidabile

15 cm – 6"

44.37.15

20 cm – 8"

44.37.20



18 cm – 7 1/8"

60.00.42

Castroviejo-Epker



18 cm – 7 1/8"

60.00.43

Castroviejo-Epker

Messbereich:
Measuring range: 40 mm
Alcance de medición:
Etendue de mesure:
Campo di misura:





TREVALLi

McINTOSH

Spatel
Blades
Espátulas
Spatules
Lame

Laryngoskope mit Fiberglas-Lichtleitung
Laryngoscopes with Fibre Optic Light Guide
Laringoscopios con conductor de luz fría
Laryngoscopes à conducteur de lumière en fibres de verre
Laringoscopi con conduttore d'illuminazione a luce fredda

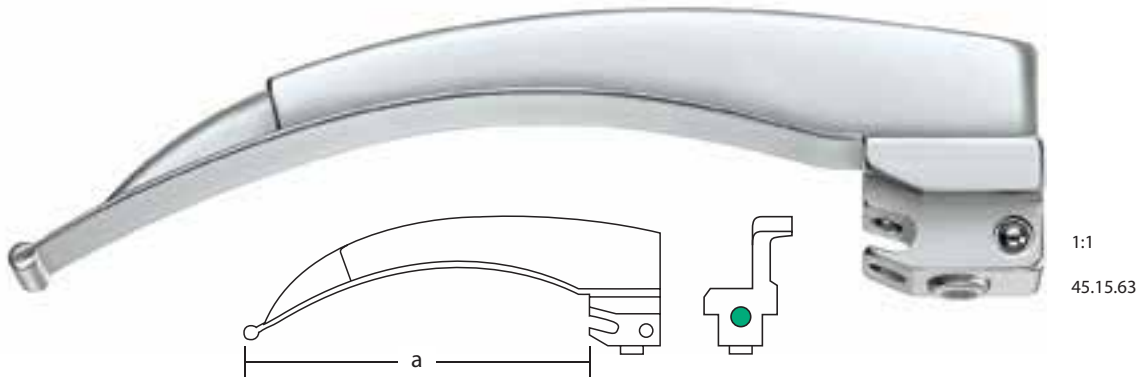

45.15.60	a = 55 mm	Fig. 0
45.15.61	a = 70 mm	Fig. 1
45.15.62	a = 90 mm	Fig. 2
45.15.63	a = 110 mm	Fig. 3
45.15.64	a = 130 mm	Fig. 4

autoklavierbar bis 134 °C bei 3 bar
 autoclavable up to 134 °C at 3 bar
 autoclavable hasta 134 °C bajo presión de 3 bar
 autoclavable jusqu'à 134 °C sous pression de 3 bars
 autoclavabile fino a 134 °C sotto pressione di 3 bar

McINTOSH

Fig. 0	Neugeborene Newborns Recién nacidos Nouveau-nés Neonati
Fig. 1	Kleinkinder Infants Niños pequeños Petits enfants Bambini piccoli
Fig. 2	Kinder Children Niños Enfants Bambini
Fig. 3	Erwachsene Adults Adultos
Fig. 4	Adultes Adulti



TREVALLi

Laryngoskope mit Fiberglas-Lichtleitung
Laryngoscopes with Fibre Optic Light Guide
Laringoscopios con conductor de luz fría
Laryngoscopes à conducteur de lumière en fibres de verre
Laringoscopi con conduttore d'illuminazione a luce fredda

McINTOSH



Satz, komplett im Etui
 Set, complete in case
 Juego, completo en estuche
 Jeu complet en étui
 Set, completo di custodia

Bestehend aus:
 Consisting of:
 Compuesto por:
 Composé de:
 Composto da:

45.15.50 **45.15.51**



Standardgriff mit Standard handle with Mango estándar con Manche standard avec Manico standard con	Batteriecontainer (1 Stück) Battery container (1 piece) Contenedor de pilas (1 unidad) Container à piles (1 pièce) Contenitore per batterie (1 pezzo)	
Spatel Blades Espátulas Spatules Lame	3 Fig. 2, 3, 4	4 Fig. 1, 2, 3, 4
Lampe Lamp Lámpara Lampe Lampadina	Krypton 2,5 V (1 Stück) Krypton 2,5 V (1 piece) Criptón de 2,5 V (1 unidad) Krypton 2,5 V (1 pièce) Krypton 2,5 V (1 pezzo)	
Batterien Batteries Pilas Piles Batterie	2 Stück 2 pieces 2 unidades 2 pièces 2 pezzi	2 Stück 2 pieces 2 unidades 2 pièces 2 pezzi
Ersatzlampe Replacement lamp Lámpara de repuesto Lampe de rechange Lampadina di ricambio	1 Stück 1 piece 1 unidad 1 pièce 1 pezzo	1 Stück 1 piece 1 unidad 1 pièce 1 pezzo



Bestehend aus:
 Consisting of:
 Compuesto por:
 Composé de:
 Composto da:

LED **LED**
45.15.56 **45.15.57**

Standardgriff mit Standard handle with Mango estándar con Manche standard avec Manico standard con	Li-Ion Induktiv-Akku (1 Stück) Li-Ion Inductive accumulator (1 piece) Li-Ion Acumulador inductivo (1 unidad) Li-Ion Accumulateur inductif (1 pièce) Li-Ion Accumulatore induttivo (1 pezzo)	
Spatel Blades Espátulas Spatules Lame	3 Fig. 2, 3, 4	4 Fig. 1, 2, 3, 4
Lampe Lamp Lámpara Lampe Lampadina	Leuchtdiode Light-emitting diode Diodo luminoso Diode électroluminescente Diodo luminescente	
Ersatzlampe Replacement lamp Lámpara de repuesto Lampe de rechange Lampadina di ricambio	---	---



TREVALLi

McINTOSH

Reklinations-Spatel (aufgewinkelt)
 Reclination Blades (angled upwards)
 Espátulas de reclinación (angulado hacia arriba)
 Spatules de réclinaison (angulaire en haut)
 Lame per reclinazione (angolate verso l'alto)

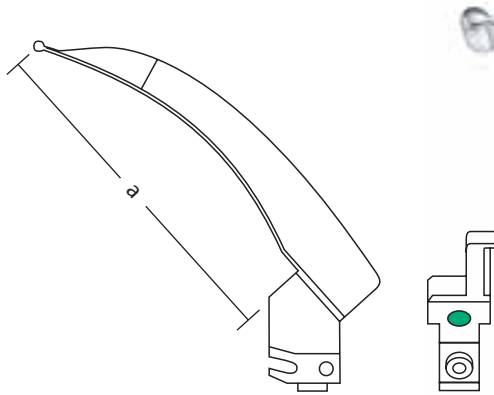

45.16.61	a = 70 mm	Fig. 1
45.16.62	a = 90 mm	Fig. 2
45.16.63	a = 110 mm	Fig. 3
45.16.64	a = 140 mm	Fig. 4

autoklavierbar bis 134 °C bei 3 bar
 autoclavable up to 134 °C at 3 bar
 autoclavable hasta 134 °C bajo presión de 3 bar
 autoclavable jusqu'à 134 °C sous pression de 3 bars
 autoclavabile fino a 134 °C sotto pressione di 3 bar

Laryngoskope mit Fiberglas-Lichtleitung
Laryngoscopes with Fibre Optic Light Guide
Laringoscopios con conductor de luz fría
Laryngoscopes à conducteur de lumière en fibres de verre
Laringoscopi con conduttore d'illuminazione a luce fredda



1:1
 45.16.62

McINTOSH

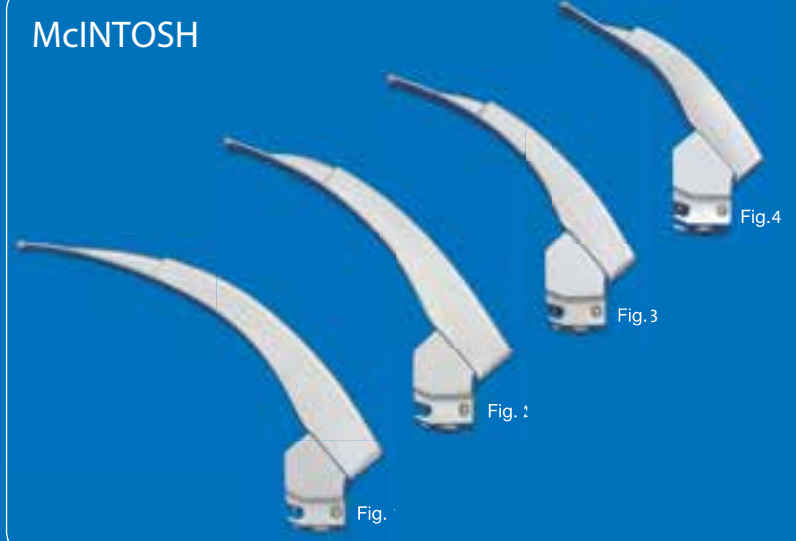

Fig. 1	Kleinkinder Infants Niños pequeños Petits enfants Bambini piccoli
Fig. 2	Kinder Children Niños Enfants Bambini
Fig. 3	Erwachsene (klein) Adults (small) Adultos (pequeño) Adultes (petit) Adulti (piccolo)
Fig. 4	Erwachsene (mittel) Adults (medium) Adultos (mediano) Adultes (moyen) Adulti (medio)



TREVALLi

Laryngoskope mit Fiberglas-Lichtleitung
Laryngoscopes with Fibre Optic Light Guide
Laringoscopios con conductor de luz fría

Laryngoscopes à conducteur de lumière en fibres de verre
Laringoscopi con conduttore d'illuminazione a luce fredda

McINTOSH

Satz, komplett im Etui
 Set, complete in case
 Juego, completo en estuche
 Jeu complet en étui
 Set, completo di custodia



Laryngoskope mit Fiberglas-Lichtleitung
Laryngoscopes with Fibre Optic Light Guide
Laringoscopios con conductor de luz fría
Laryngoscopes à conducteur de lumière en fibres de verre
Laringoscopi con conduttore d'illuminazione a luce fredda



Bestehend aus:
 Consisting of:
 Compuesto por:
 Composé de:
 Composto da:

45.16.50 **45.16.51**

Lampe Lamp Lámpara Lampe Lampadina	Krypton 2,5 V (1 Stück) Krypton 2,5 V (1 piece) Cripton de 2,5 V (1 unidad) Krypton 2,5 V (1 pièce) Krypton 2,5 V (1 pezzo)	
Spatel Blades Espátulas Spatules Lame	3 Fig. 2, 3, 4	4 Fig. 1, 2, 3, 4
Standardgriff mit Standard handle with Mango estándar con Manche standard avec Manico standard con	Batteriecontainer (1 Stück) Battery container (1 piece) Contenedor de pilas (1 unidad) Container à piles (1 pièce) Contentitore per batterie (1 pezzo)	
Batterien Batteries Pilas Piles Batterie	2 Stück 2 pieces 2 unidades 2 pièces 2 pezzi	2 Stück 2 pieces 2 unidades 2 pièces 2 pezzi
Ersatzlampe Replacement lamp Lámpara de repuesto Lampe de rechange Lampadina di ricambio	1 Stück 1 piece 1 unidad 1 pièce 1 pezzo	1 Stück 1 piece 1 unidad 1 pièce 1 pezzo



Bestehend aus:
 Consisting of:
 Compuesto por:
 Composé de:
 Composto da:

LED **LED**
45.16.56 **45.16.57**

Lampe Lamp Lámpara Lampe Lampadina	Leuchtdiode Light-emitting diode Diodo luminoso Diode électroluminescente Diodo luminescente	
Spatel Blades Espátulas Spatules Lame	3 Fig. 2, 3, 4	4 Fig. 1, 2, 3, 4
Standardgriff mit Standard handle with Mango estándar con Manche standard avec Manico standard con	Li-Ion Induktiv-Akku (1 Stück) Li-Ion Inductive accumulator (1 piece) Li-Ion Acumulador inductivo (1 unidad) Li-Ion Accumulateur inductif (1 pièce) Li-Ion Accumulatore induttivo (1 pezzo)	
Ersatzlampe Replacement lamp Lámpara de repuesto Lampe de rechange Lampadina di ricambio	---	---



TREVALLi

McINTOSH

Spatel mit auswechselbarem Lichtträger
 Blades with exchangeable light carrier
 Espátulas con portador de luz fría intercambiable
 Spatules avec porteur de lumière échangeable
 Lame con portatore d'illuminazione intercambiabile

Laryngoskope mit Fiberglas-Lichtleitung
Laryngoscopes with Fibre Optic Light Guide
Laringoscopios con conductor de luz fría
Laryngoscopes à conducteur de lumière en fibres de verre
Laringoscopi con conduttore d'illuminazione a luce fredda

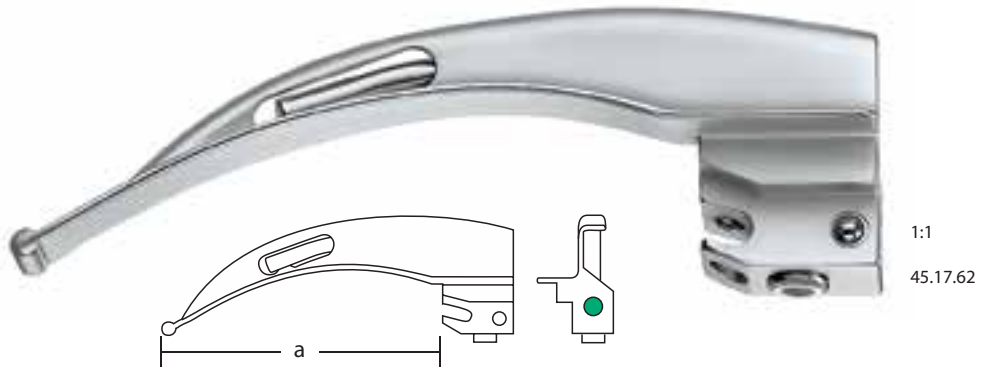

45.17.61	a = 70 mm	Fig. 1
45.17.62	a = 90 mm	Fig. 2
45.17.63	a = 110 mm	Fig. 3
45.17.64	a = 130 mm	Fig. 4

autoklavierbar bis 134 °C bei 3 bar
 autoclavable up to 134 °C at 3 bar
 autoclavable hasta 134 °C bajo presión de 3 bar
 autoclavable jusqu'à 134 °C sous pression de 3 bars
 autoclavabile fino a 134 °C sotto pressione di 3 bar



Lichtträger allein
 Light carriers only
 Portadores de luz solos
 Supports de lumière seuls
 Supporti per illuminazione soli

45.17.81	Fig. 1
45.17.82	Fig. 2
45.17.83	Fig. 3
45.17.84	Fig. 4

McINTOSH

Fig. 1	Kleinkinder Infants Niños pequeños Petits enfants Bambini piccoli
Fig. 2	Kinder Children Niños Enfants Bambini
Fig. 3	Erwachsene Adults Adultos
Fig. 4	Adultes Adulti



TREVALLI

Laryngoskope mit Fiberglas-Lichtleitung
Laryngoscopes with Fibre Optic Light Guide
Laringoscopios con conductor de luz fría
Laryngoscopes à conducteur de lumière en fibres de verre
Laringoscopi con conduttore d'illuminazione a luce fredda

Satz, komplett im Etui
 Set, complete in case
 Juego, completo en estuche
 Jeu complet en étui
 Set, completo di custodia



McINTOSH



Bestehend aus:
 Consisting of:
 Compuesto por:
 Composé de:
 Composto di:

45.17.50 **45.17.51**

Lampe Lamp Lámpara Lampe Lampadina	Krypton 2,5 V (1 Stück) Krypton 2,5 V (1 piece) Cripton de 2,5 V (1 unidad) Krypton 2,5 V (1 pièce) Krypton 2,5 V (1 pezzo)	
Spatel Blades Espátulas Spatules Lame	3 Fig. 2, 3, 4	4 Fig. 1, 2, 3, 4
Standardgriff mit Standard handle with Mango estándar con Manche standard avec Manico standard con	Batteriecontainer (1 Stück) Battery container (1 piece) Contenedor de pilas (1 unidad) Container à piles (1 pièce) Contentitore per batterie (1 pezzo)	
Batterien Batteries Pilas Piles Batterie	2 Stück 2 pieces 2 unidades 2 pièces 2 pezzi	2 Stück 2 pieces 2 unidades 2 pièces 2 pezzi
Ersatzlampe Replacement lamp Lámpara de repuesto Lampe de rechange Lampadina di ricambio	1 Stück 1 piece 1 unidad 1 pièce 1 pezzo	1 Stück 1 piece 1 unidad 1 pièce 1 pezzo

Bestehend aus:
 Consisting of:
 Compuesto por:
 Composé de:
 Composto di:

LED **LED**
45.17.56 **45.17.57**

Lampe Lamp Lámpara Lampe Lampadina	Leuchtdiode Light-emitting diode Diodo luminoso Diode électroluminescente Diodo luminescente	
Spatel Blades Espátulas Spatules Lame	3 Fig. 2, 3, 4	4 Fig. 1, 2, 3, 4
Standardgriff mit Standard handle with Mango estándar con Manche standard avec Manico standard con	Li-Ion Induktiv-Akku (1 Stück) Li-Ion Inductive accumulator (1 piece) Li-Ion Acumulador inductivo (1 unidad) Li-Ion Accumulateur inductif (1 pièce) Li-Ion Accumulatore induttivo (1 pezzo)	
Ersatzlampe Replacement lamp Lámpara de repuesto Lampe de rechange Lampadina di ricambio	---	---



TREVALLi

FOREGGER

Spatel
Blades
Espátulas
Spatules
Lame

Laryngoskope mit Fiberglas-Lichtleitung
Laryngoscopes with Fibre Optic Light Guide
Laringoscopios con conductor de luz fría
Laryngoscopes à conducteur de lumière en fibres de verre
Laringoscopi con conduttore d'illuminazione a luce fredda

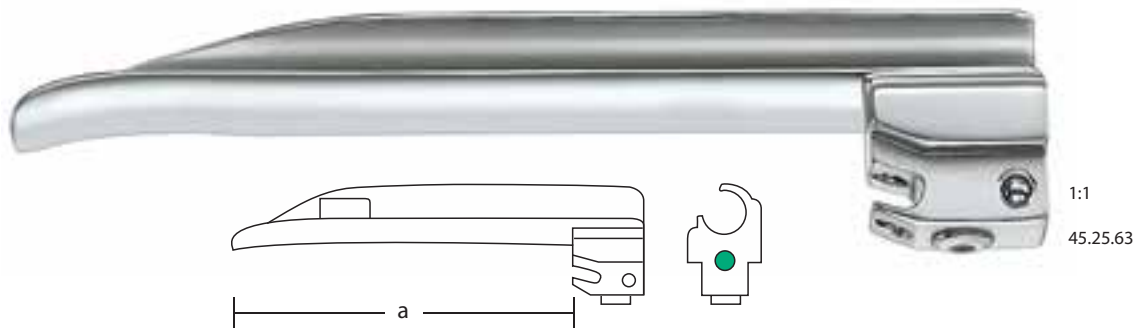

45.25.60	a = 55 mm	Fig. 0
45.25.61	a = 70 mm	Fig. 1
45.25.62	a = 90 mm	Fig. 2
45.25.63	a = 110 mm	Fig. 3
45.25.64	a = 130 mm	Fig. 4

autoklavierbar bis 134 °C bei 3 bar
 autoclavable up to 134 °C at 3 bar
 autoclavable hasta 134 °C bajo presión de 3 bar
 autoclavable jusqu'à 134 °C sous pression de 3 bars
 autoclavabile fino a 134 °C sotto pressione di 3 bar

FOREGGER

Fig. 0		Fig. 0	Neugeborene Newborns Recién nacidos Nouveau-nés Neonati
Fig. 1		Fig. 1	Kleinkinder Infants Niños pequeños Petits enfants Bambini piccoli
Fig. 2		Fig. 2	Kinder Children Niños Enfants Bambini
Fig. 3		Fig. 3	Erwachsene Adults Adultos Adultes Adulti



TREVALLI

Laryngoskope mit Fiberglas-Lichtleitung
Laryngoscopes with Fibre Optic Light Guide
Laringoscopios con conductor de luz fría
Laryngoscopes à conducteur de lumière en fibres de verre
Laringoscopi con conduttore d'illuminazione a luce fredda

A18

FOREGGER

Satz komplett im Etui
 Set complete in case
 Juego completo en estuche
 Jeu complet en étui
 Set completo di custodia



Bestehend aus:
 Consisting of:
 Compuesto por:
 Composé de:
 Composto da:

45.25.50

45.25.51

Lampe Lamp Lámpara Lampe Lampadina	Krypton 2,5 V (1 Stück) Krypton 2,5 V (1 piece) Cripton de 2,5 V (1 unidad) Krypton 2,5 V (1 pièce) Krypton 2,5 V (1 pezzo)	
Spatel Blades Espátulas Spatules Lame	3 Fig. 2, 3, 4	4 Fig. 1, 2, 3, 4
Standardgriff mit Standard handle with Mango estándar con Manche standard avec Manico standard con	Batteriecontainer (1 Stück) Battery container (1 piece) Contenedor de pilas (1 unidad) Container à piles (1 pièce) Contentitore per batterie (1 pezzo)	
Batterien Batteries Pilas Piles Batterie	2 Stück 2 pieces 2 unidades 2 pièces 2 pezzi	2 Stück 2 pieces 2 unidades 2 pièces 2 pezzi
Ersatzlampe Replacement lamp Lámpara de repuesto Lampe de rechange Lampadina di ricambio	1 Stück 1 piece 1 unidad 1 pièce 1 pezzo	1 Stück 1 piece 1 unidad 1 pièce 1 pezzo



Bestehend aus:
 Consisting of:
 Compuesto por:
 Composé de:
 Composto da:

LED

LED

45.25.56

45.25.57

Lampe Lamp Lámpara Lampe Lampadina	Leuchtdiode Light-emitting diode Diodo luminoso Diode électroluminescente Diodo luminescente	
Spatel Blades Espátulas Spatules Lame	3 Fig. 2, 3, 4	4 Fig. 1, 2, 3, 4
Standardgriff mit Standard handle with Mango estándar con Manche standard avec Manico standard con	Li-Ion Induktiv-Akku (1 Stück) Li-Ion Inductive accumulator (1 piece) Li-Ion Acumulador inductivo (1 unidad) Li-Ion Accumulateur inductif (1 pièce) Li-Ion Accumulatore induttivo (1 pezzo)	
Ersatzlampe Replacement lamp Lámpara de repuesto Lampe de rechange Lampadina di ricambio	---	---



TREVALLi

MILLER

Spatel
Blades
Espátulas
Spatules
Lame

Laryngoskope mit Fiberglas-Lichtleitung
Laryngoscopes with Fibre Optic Light Guide
Laringoscopios con conductor de luz fría
Laryngoscopes à conducteur de lumière en fibres de verre
Laringoscopi con conduttore d'illuminazione a luce fredda

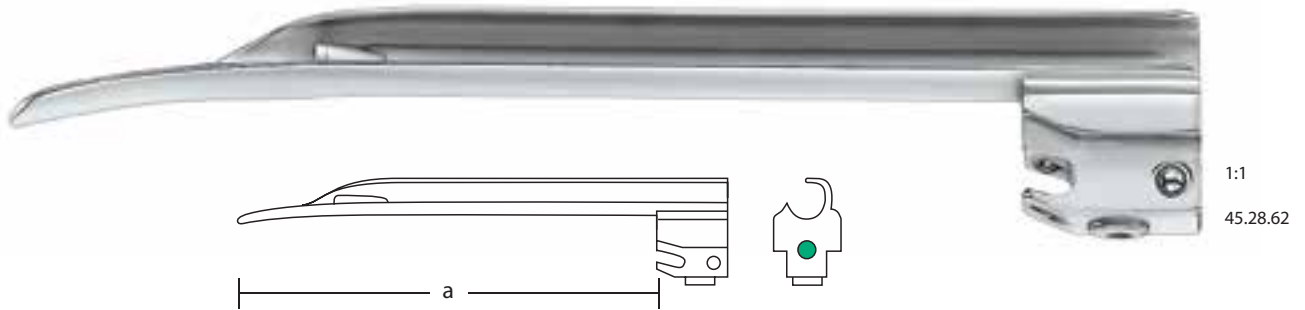

45.28.60	a = 55 mm	Fig. 0
45.28.61	a = 80 mm	Fig. 1
45.28.62	a = 130 mm	Fig. 2
45.28.63	a = 170 mm	Fig. 3
45.28.64	a = 190 mm	Fig. 4

autoklavierbar bis 134 °C bei 3 bar
 autoclavable up to 134 °C at 3 bar
 autoclavable hasta 134 °C bajo presión de 3 bar
 autoclavable jusqu'à 134 °C sous pression de 3 bars
 autoclavabile fino a 134 °C sotto pressione di 3 bar

MILLER

Fig. 0	Fig. 0	Neugeborene Newborns Recién nacidos Nouveau-nés Neonati
Fig. 1	Fig. 1	Kleinkinder Infants Niños pequeños Petits enfants Bambini piccoli
Fig. 2	Fig. 2	Kinder Children Niños Enfants Bambini
Fig. 3	Fig. 3	Erwachsene Adults Adultos
Fig. 4	Fig. 4	Adultes Adulti



TREVALLI Laryngoskope mit Fiberglas-Lichtleitung
Laryngoscopes with Fibre Optic Light Guide
Laringoscopios con conductor de luz fría
Laryngoscopes à conducteur de lumière en fibres de verre
Laringoscopi con conduttore d'illuminazione a luce fredda

Satz komplett im Etui
 Set complete in case
 Juego completo en estuche
 Jeu complet en étui
 Set completo di custodia

MILLER



Bestehend aus:
 Consisting of:
 Compuesto por:
 Composé de:
 Composto da:

45.28.50 **45.28.51**

Lampe Lamp Lámpara Lampe Lampadina	Krypton 2,5 V (1 Stück) Krypton 2,5 V (1 piece) Cripton de 2,5 V (1 unidad) Krypton 2,5 V (1 pièce) Krypton 2,5 V (1 pezzo)	
Spatel Blades Espátulas Spatules Lame	3 Fig. 2, 3, 4	4 Fig. 1, 2, 3, 4
Standardgriff mit Standard handle with Mango estándar con Manche standard avec Manico standard con	Batteriecontainer (1 Stück) Battery container (1 piece) Contenedor de pilas (1 unidad) Container à piles (1 pièce) Contentitore per batterie (1 pezzo)	
Batterien Batteries Pilas Piles Batterie	2 Stück 2 pieces 2 unidades 2 pièces 2 pezzi	2 Stück 2 pieces 2 unidades 2 pièces 2 pezzi
Ersatzlampe Replacement lamp Lámpara de repuesto Lampe de rechange Lampadina di ricambio	1 Stück 1 piece 1 unidad 1 pièce 1 pezzo	1 Stück 1 piece 1 unidad 1 pièce 1 pezzo



Bestehend aus:
 Consisting of:
 Compuesto por:
 Composé de:
 Composto da:

LED **LED**
45.28.56 **45.28.57**

Lampe Lamp Lámpara Lampe Lampadina	Leuchtdiode Light-emitting diode Diodo luminoso Diode électroluminescente Diodo luminescente	
Spatel Blades Espátulas Spatules Lame	3 Fig. 2, 3, 4	4 Fig. 1, 2, 3, 4
Standardgriff mit Standard handle with Mango estándar con Manche standard avec Manico standard con	Li-Ion Induktiv-Akku (1 Stück) Li-Ion Inductive accumulator (1 piece) Li-Ion Acumulador inductivo (1 unidad) Li-Ion Accumulateur inductif (1 pièce) Li-Ion Accumulatore induttivo (1 pezzo)	
Ersatzlampe Replacement lamp Lámpara de repuesto Lampe de rechange Lampadina di ricambio	---	---



TREVALLi

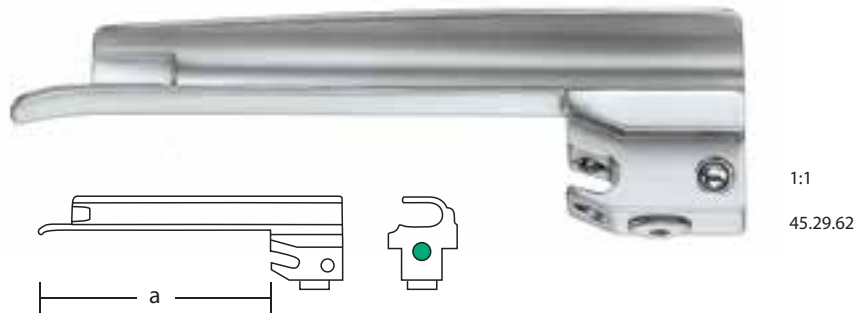

Laryngoskope mit Fiberglas-Lichtleitung
Laryngoscopes with Fibre Optic Light Guide
Laringoscopios con conductor de luz fría
Laryngoscopi con conduttore d'illuminazione a luce fredda

Pädiatrie-Spatel
Pediatric blades
Espátulas de pediátricos
Spatules de pédiatriques
Lame per pediatria



45.29.60	a = 40 mm	Fig. 0
45.29.61	a = 55 mm	Fig. 1
45.29.62	a = 70 mm	Fig. 2

autoklavierbar bis 134 °C bei 3 bar
autoclavable up to 134 °C at 3 bar
autoclavable hasta 134 °C bajo presión de 3 bar
autoclavable jusqu'à 134 °C sous pression de 3 bars
autoclavabile fino a 134 °C sotto pressione di 3 bar

	Fig. 0	Neugeborene Newborns Recién nacidos Nouveau-nés Neonati
	Fig. 1	Kleinkinder Infants Niños pequeños Petits enfants Bambini piccoli
	Fig. 2	Kinder Children Niños Enfants Bambini



TREVALLI

Laryngoskope mit Fiberglas-Lichtleitung
Laryngoscopes with Fibre Optic Light Guide
Laringoscopios con conductor de luz fría
Laryngoscopes à conducteur de lumière en fibres de verre
Laringoscopi con conduttore d'illuminazione a luce fredda

Satz komplett im Etui
 Set complete in case
 Juego completo en estuche
 Jeu complet en étui
 Set completo di custodia



Bestehend aus:
 Consisting of:
 Compuesto por:
 Composé de:
 Composto da:

45.29.50

Lampe Lamp Lámpara Lampe Lampadina	Krypton 2,5 V (1 Stück) Krypton 2,5 V (1 piece) Cripton de 2,5 V (1 unidad) Krypton 2,5 V (1 pièce) Krypton 2,5 V (1 pezzo)
Spatel Blades Espátulas Spatules Lame	3 Fig. 0, 1, 2
Standardgriff mit Standard handle with Mango estándar con Manche standard avec Manico standard con	Batteriecontainer (1 Stück) Battery container (1 piece) Contenedor de pilas (1 unidad) Container à piles (1 pièce) Contentitore per batterie (1 pezzo)
Batterien Batteries Pilas Piles Batterie	2 Stück 2 pieces 2 unidades 2 pièces 2 pezzi
Ersatzlampe Replacement lamp Lámpara de repuesto Lampe de rechange Lampadina di ricambio	1 Stück 1 piece 1 unidad 1 pièce 1 pezzo

Bestehend aus:
 Consisting of:
 Compuesto por:
 Composé de:
 Composto da:

LED

45.29.56

Lampe Lamp Lámpara Lampe Lampadina	Leuchtdiode Light-emitting diode Diodo luminoso Diode électroluminescente Diodo luminescente
Spatel Blades Espátulas Spatules Lame	3 Fig. 0, 1, 2
Standardgriff mit Standard handle with Mango estándar con Manche standard avec Manico standard con	Li-Ion Induktiv-Akku (1 Stück) Li-Ion Inductive accumulator (1 piece) Li-Ion Acumulador inductivo (1 unidad) Li-Ion Accumulateur inductif (1 pièce) Li-Ion Accumulatore induttivo (1 pezzo)
Ersatzlampe Replacement lamp Lámpara de repuesto Lampe de rechange Lampadina di ricambio	---



TREVALLi

McINTOSH

Spatel
Blades
Espátulas
Spatules
Lame

Laryngoskope mit Fiberglas-Lichtleitung
Laryngoscopes with Fibre Optic Light Guide
Laringoscopes con conductor de luz fría
Laryngoscopes à conducteur de lumière en fibres de verre
Laringoscopi con conduttore d'illuminazione a luce fredda

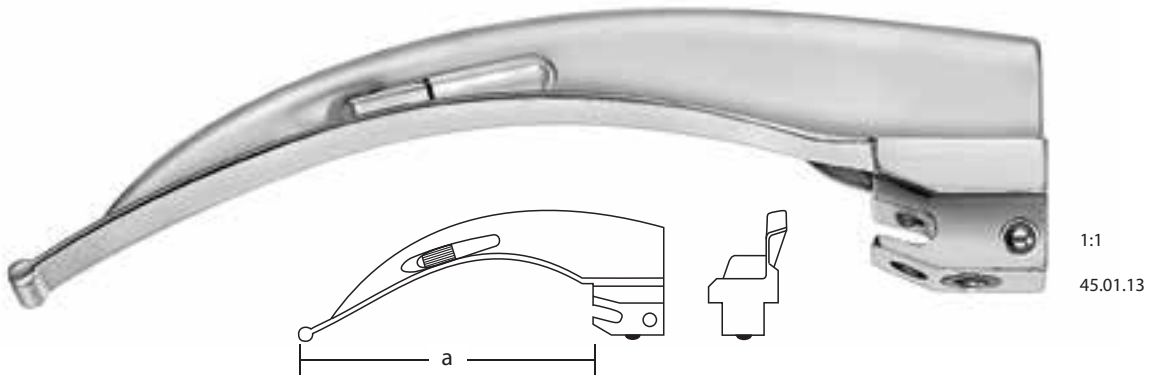

45.01.10	a = 55 mm	Fig. 0
45.01.11	a = 70 mm	Fig. 1
45.01.12	a = 90 mm	Fig. 2
45.01.13	a = 110 mm	Fig. 3
45.01.14	a = 130 mm	Fig. 4
45.01.15	a = 150 mm	Fig. 5

autoklavierbar bis 134 °C bei 3 bar
 autoclavable up to 134 °C at 3 bar
 autoclavable hasta 134 °C bajo presión de 3 bar
 autoclavable jusqu'à 134 °C sous pression de 3 bars
 autoclavabile fino a 134 °C sotto pressione di 3 bar

McINTOSH

<p>Fig. 0</p>	<p>Neugeborene Newborns Recién nacidos Nouveau-nés Neonati</p>
<p>Fig. 1</p>	<p>Kleinkinder Infants Niños pequeños Petits enfants Bambini piccoli</p>
<p>Fig. 2</p>	<p>Kinder Children Niños Enfants Bambini</p>
<p>Fig. 3</p>	<p>Erwachsene (groß) Adults (large)</p>
<p>Fig. 4</p>	<p>Adultos (grande) Adultes (large)</p>
<p>Fig. 5</p>	<p>Adulti (grande)</p>



TREVALLI

Laryngoskope mit Fiberglas-Lichtleitung
Laryngoscopes with Fibre Optic Light Guide
Laringoscopios con conductor de luz fría
Laryngoscopes à conducteur de lumière en fibres de verre
Laringoscopi con conduttore d'illuminazione a luce fredda

Satz komplett im Etui
 Set complete in case
 Juego completo en estuche
 Jeu complet en étui
 Set completo di custodia



Bestehend aus:
 Consisting of:
 Compuesto por:
 Composé de:
 Composto da:

	45.01.00	45.01.05
Spatel Blades Espátulas Spatules Lame	3 Fig. 2, 3, 4	4 Fig. 1, 2, 3, 4
Standardgriff mit Standard handle with Mango estándar con Manche standard avec Manico standard con		Batterien (2 Stück) Batteries (2 pieces) Pilas (2 unidades) Piles (2 pièces) Batterie (2 pezzi)
Ersatzlampen Replacement lamps Lámparas de repuesto Lampes de rechange Lampadine di ricambio		2 Stück 2 pieces 2 unidades 2 pièces 2 pezzi

McINTOSH



Ersatzlampen für:		45.01.12
Replacement lamps for:	45.01.10	45.01.13
Lámparas de repuesto para:	45.01.11	45.01.14
Lampes de rechange pour:		45.01.15
Lampadine di ricambio per:		

Verpackungseinheit 6 Stück
 Packing unit 6 pieces
 Paquete de 6 unidades
 Emballage de 6 pièces
 Confezione da 6 pezzi



45.48.65



45.48.66





TREVALLi

WIS-FOREGGER

(WISCONSIN)

Laryngoskope mit Fiberglas-Lichtleitung
Laryngoscopes with Fibre Optic Light Guide
Laringoscopios con conductor de luz fría
Laryngoscopes à conducteur de lumière en fibres de verre
Laringoscopi con conduttore d'illuminazione a luce fredda

Spatel
 Blades
 Espátulas
 Spatules
 Lame

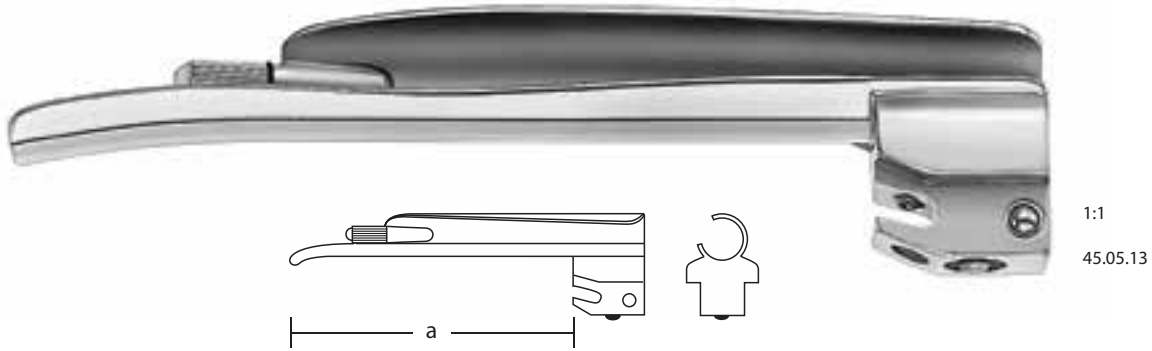

45.05.10	a = 55 mm	Fig. 0
45.05.11	a = 70 mm	Fig. 1
45.05.12	a = 90 mm	Fig. 2
45.05.13	a = 110 mm	Fig. 3
45.05.14	a = 135 mm	Fig. 4

autoklavierbar bis 134 °C bei 3 bar
 autoclavable up to 134 °C at 3 bar
 autoclavable hasta 134 °C bajo presión de 3 bar
 autoclavable jusqu'à 134 °C sous pression de 3 bars
 autoclavabile fino a 134 °C sotto pressione di 3 bar

WIS-FOREGGER
(WISCONSIN)

Fig. 0	Fig. 0	Neugeborene Newborns Recién nacidos Nouveaux-nés Neonati
Fig. 1	Fig. 1	Kleinkinder Infants Niños pequeños Petits enfants Bambini piccoli
Fig. 2	Fig. 2	Kinder Children Niños Enfants Bambini
Fig. 3	Fig. 3	Erwachsene Adults Adultos Adultes Adulti
Fig. 4	Fig. 4	



TREVALLI

Laryngoskope mit Fiberglas-Lichtleitung
Laryngoscopes with Fibre Optic Light Guide
Laringoscopios con conductor de luz fría
Laryngoscopes à conducteur de lumière en fibres de verre
Laringoscopi con conduttore d'illuminazione a luce fredda

WIS-FOREGGER

(WISCONSIN)

Satz komplett im Etui
 Set complete in case
 Juego completo en estuche
 Jeu complet en étui
 Set completo di custodia



Bestehend aus:
 Consisting of:
 Compuesto por:
 Composé de:
 Composto da:

	45.05.50	45.05.51
Spatel Blades Espátulas Spatules Lame	3 Fig. 2, 3, 4	4 Fig. 1, 2, 3, 4
Standardgriff mit Standard handle with Mango estándar con Manche standard avec Manico standard con	Batterien (2 Stück) Batteries (2 pieces) Pilas (2 unidades) Piles (2 pièces) Batterie (2 pezzi)	
Ersatzlampen Replacement lamps Lámparas de repuesto Lampes de rechange Lampadine di ricambio	2 Stück 2 pieces 2 unidades 2 pièces 2 pezzi	

Ersatzlampen für: Replacement lamps for:	45.05.10	45.05.12
Lámparas de repuesto para:	45.05.11	45.05.13
Lampes de rechange pour:		45.05.14
Lampadine di ricambio per:		

Verpackungseinheit 6 Stück Packing unit 6 pieces Paquete de 6 unidades Emballage de 6 pièces Confezione da 6 pezzi	 45.48.65	 45.48.66
--	---	---





TREVALLi

MILLER

Spatel
Blades
Espátulas
Spatules
Lame

Laryngoskope mit Fiberglas-Lichtleitung
Laryngoscopes with Fibre Optic Light Guide
Laringoscopios con conductor de luz fría
Laryngoscopi con conduttore d'illuminazione a luce fredda

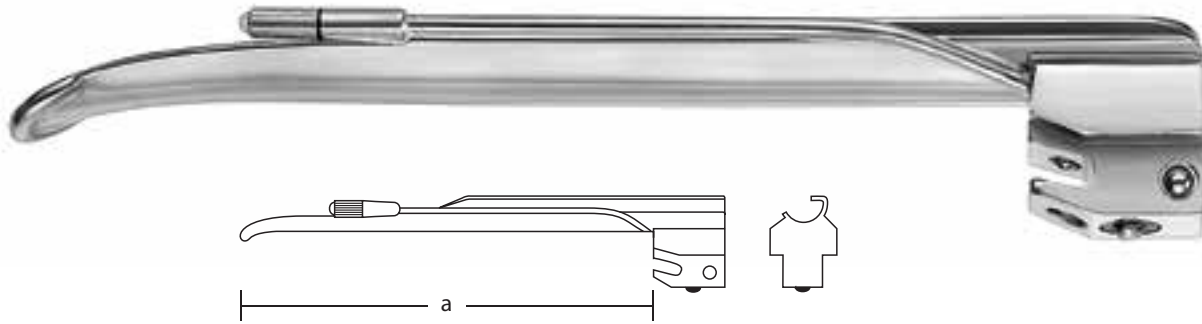

1:1
45.08.32

45.08.30	a = 55 mm	Fig. 0
45.08.31	a = 80 mm	Fig. 1
45.08.32	a = 130 mm	Fig. 2
45.08.33	a = 170 mm	Fig. 3
45.08.34	a = 180 mm	Fig. 4

autoklavierbar bis 134 °C bei 3 bar
 autoclavable up to 134 °C at 3 bar
 autoclavable hasta 134 °C bajo presión de 3 bar
 autoclavable jusqu'à 134 °C sous pression de 3 bars
 autoclavabile fino a 134 °C sotto pressione di 3 bar

MILLER

Fig. 0	Fig. 0	Neugeborene Newborns Recién nacidos Nouveau-nés Neonati
Fig. 1	Fig. 1	Kleinkinder Infants Niños pequeños Petits enfants Bambini piccoli
Fig. 2	Fig. 2	Kinder Children Niños Enfants Bambini
Fig. 3	Fig. 3	Erwachsene Adults Adultos Adultes Adulti
Fig. 4	Fig. 4	



TREVALLI

Laryngoskope mit Fiberglas-Lichtleitung
Laryngoscopes with Fibre Optic Light Guide
Laringoscopios con conductor de luz fría
Laryngoscopes à conducteur de lumière en fibres de verre
Laringoscopi con conduttore d'illuminazione a luce fredda

Satz komplett im Etui
 Set complete in case
 Juego completo en estuche
 Jeu complet en étui
 Set completo di custodia

MILLER



Bestehend aus:
Consisting of:
Compuesto por:
Composé de:
Composto da:

	45.08.50	45.08.51
Spatel Blades Espátulas Spatulas Lame	3 Fig. 2, 3, 4	4 Fig. 1, 2, 3, 4
Standardgriff mit Standard handle with Mango estándar con Manche standard avec Manico standard con	Batterien (2 Stück) Batteries (2 pieces) Pilas (2 unidades) Piles (2 pièces) Batterie (2 pezzi)	
Ersatzlampen Replacement lamps Lámparas de repuesto Lampes de rechange Lampadine di ricambio	2 Stück 2 pieces 2 unidades 2 pièces 2 pezzi	

Ersatzlampen für:	45.08.30	
Replacement lamps for:	45.08.31	45.08.34
Lámparas de repuesto para:	45.08.32	
Lampes de rechange pour:	45.08.33	
Lampadine di ricambio per:		

Verpackungseinheit 6 Stück
 Packing unit 6 pieces
 Paquete de 6 unidades
 Emballage de 6 pièces
 Confezione da 6 pezzi



45.48.65



45.48.66





TREBALLI

Zubehör für Laryngoskope mit Fiberglas-Lichtleitung
Accessories for Laryngoscopes with Fibre Optic Light Guide
Accesorios para laringoscopios con conductor de luz fría

Griffe
 Handles
 Mangos
 Manches
 Manici

standard
 standard
 estándar
 standard
 standard

schlank
 slim
 fino
 élancé
 sottile



autoklavierbar bis 134 °C bei 3 bar
 autoclavable up to 134 °C at 3 bar
 autoclavable hasta 134 °C bajo presión de 3 bar
 autoclavable jusqu'à 134 °C sous pression de 3 bars
 autoclavabile fino a 134 °C sotto pressione di 3 bar

BATTERY

allein, mit Deckel (ohne Lampe und Batteriecontainer)
 only, with lid (without lamp and battery container)
 solo, con tapa (sin lámpara y contenedor de pilas)
 seul, avec couvercle (sans lampe et container à piles)
 solo, con coperchio (senza lampadina e contenitore per batterie)

45.48.49

45.48.79

mit Batteriecontainer (2 x Batterien und Kryptonlampe)
 with battery container (2 x Batteries and krypton lamp)
 con contenedor de pilas (2 x Pilas y lámpara de criptón)
 avec container à piles (2 x Piles et lampe krypton)
 con contenitore per batterie (2 x batterie e lampadina krypton)

2,5 V

45.48.50

45.48.80

mit Batteriecontainer (2 x Batterien und Xenonlampe)
 with battery container (2 x Batteries and xenon lamp)
 con contenedor de pilas (2 x Pilas y lámpara de xenón)
 avec container à piles (2 x Piles et lampe xénon)
 con contenitore per batterie (2 x batterie e lampadina xenon)

2,5 V

45.48.51

45.48.81

Batteriecontainer
 Battery container
 Contenedor de pilas
 Container à piles
 Contenitore per batterie

leer, ohne Lampe
 empty, without lamp
 vacío, sin lámpara
 vide, sans lampe
 vuoto, senza lampadina

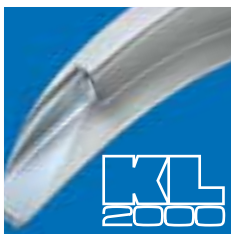

45.48.54

45.48.84

Ersatzdeckel
 Replacement lids
 Tapas de repuesto
 Couvercles de rechange
 Coperchi di ricambio



904.50.17

904.50.18



TREVALLi

Zubehör für Laryngoskope mit Fiberglas-Lichtleitung
Accessories for Laryngoscopes with Fibre Optic Light Guide
Accesorios para laringoscopios con conductor de luz fría
Accessoires pour laryngoscopes à conducteur de lumière en fibres de verre
Accessori per laringoscopi con conduttore d'illuminazione a luce fredda

Xenonlampe
 Xenon lamp
 Lámpara de xenón
 Lampe xénon
 Lampadina xenon



2,5 V

45.48.72



3,0 V

45.48.73

Kryptonlampe
 Krypton lamp
 Lámpara de criptón
 Lampe krypton
 Lampadina krypton



2,5 V

45.48.70

Die Lichtleistung von Xenonlampen ist um ein mehrfaches höher als die einer Kryptonlampe. Ein weiterer Vorteil von Xenonlampen ist deren "weißes Licht", das von den Mund- und Rachenschleimhäuten weniger absorbiert wird und die Kontrastdarstellung verbessert.

The intensity of the light of xenon lamps is several times higher than that of krypton lamps. Another advantage of xenon lamps is their "white light", which reduces the light absorption of the mucosa and improves the contrast effect.

La potencia luminosa de las lámparas de xenón es mucho mayor que la de las lámparas de criptón. Otra de las ventajas de las lámparas de xenón es su "luz blanca" que es menos absorbida por la mucosa bucal y faringea mejorando así la visualización de contrastes.

La puissance de lumière des lampes xénon est beaucoup plus grande que celle des lampes krypton. Un autre avantage des lampes xénon est leur "lumière blanche" qui est moins absorbée par la muqueuse buccale et par la muqueuse pharyngienne et mène donc à un graphique de contraste amélioré.

La potenza luminosa delle lampadine xenon è maggiore a quella di una lampadina krypton. Un altro vantaggio della lampadina xenon è la "luce bianca", che viene meno assorbita dalla mucosa faringea e dalla mucosa orale e produce un contrasto migliore.

Batterien
 Batteries
 Pilas
 Piles
 Batterie

standard
 standard
 estándar
 standard
 standard



45.49.92

R14 (1,5 V)



schlank
 slim
 fino
 élançé
 sottile

45.49.91

R6 (1,5 V)

2 Stück werden benötigt
 2 pieces needed
 se necesita 2 piezas
 2 pièces requises
 sono necessari 2 pezzi

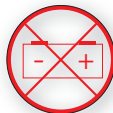

Batterien, Batteriecontainer und Akku-Einsätze sind vor der Sterilisation aus den Griffen zu entnehmen.

Batteries, battery container and accumulator inserts must be removed from the handles prior to sterilization.

Antes de la esterilización deben desmontarse de los mangos las pilas, el contenedor de pilas y los acumuladores.

Les piles, les containers à piles et les accumulateurs doivent être enlevés des manches avant la stérilisation.

Le batterie, i contenitori per batterie e gli accumulatori devono essere tolti prima della sterilizzazione.



TREVALLi

Zubehör für Laryngoskope mit Fiberglas-Lichtleitung
Accessories for Laryngoscopes with Fibre Optic Light Guide
Accesorios para laringoscopios con conductor de luz fría
Accessoires pour laryngoscopes à conducteur de lumière en fibres de verre
Accessori per laringoscopi con conduttore d'illuminazione a luce fredda

Griff
 Handle
 Mango
 Manche
 Manico

standard
 standard
 estándar
 standard
 standard

autoklavierbar bis 134 °C bei 3 bar
 autoclavable up to 134 °C at 3 bar
 autoclavable hasta 134 °C bajo presión de 3 bar
 autoclavable jusqu'à 134 °C sous pression de 3 bars
 autoclavabile fino a 134 °C sotto pressione di 3 bar



LED
45.48.27

mit Li-Ion Induktiv-Akku und Leuchtdiode
 with Li-ion inductive accumulator and light-emitting diode
 con acumulador inductivo Li-ion y diodo luminoso
 avec accumulateur inductif Li-ion et diode électroluminescente
 con accumulatore induttivo Li-ion e diodo luminescente

ACCUMULATOR

Induktiv-Akku
 Inductive accumulator
 Acumulador inductivo
 Accumulateur inductif
 Accumulatore induttivo



Li-Ion

LED
45.48.26

mit Leuchtdiode
 with light-emitting diode
 con diodo luminoso
 avec diode électroluminescente
 con diodo luminoso



TREVALLi

Griffe
Handles
Mangos
Manches
Manici

autoklavierbar bis 134 °C bei 3 bar
autoclavable up to 134 °C at 3 bar
autoclavable hasta 134 °C bajo presión de 3 bar
autoclavable jusqu'à 134 °C sous pression de 3 bars
autoclavabile fino a 134 °C sotto pressione di 3 bar

standard
standard
estándar
standard
standard



45.48.12



schlank
slim
fino
élançé
sottile

45.48.11

BATTERY

komplett mit 2 Batterien
complete with 2 batteries
completo con 2 pilas
complèt avec 2 piles
completo con 2 batterie

leer, mit Deckel
empty, with lid
vacío, con tapa
vide, avec couvercle
vuoto, con coperchio

45.49.75

45.49.74

Ersatzdeckel
Replacement lids Tapas
de repuesto
Couvercles de rechange
Coperchi di ricambio



45.49.72



45.49.71



TREVALLi

für Li-Ion Akku
for Li-ion accumulator
para acumulador Li-ion
pour accumulateur Li-ion
per accumulatore Li-ion



LED
45.49.98

110-240 V

nur für Induktiv-Akkus (LED) only for inductive accumulators (LED) solo para acumuladores inductivos (LED) seulement conçu pour les accumulateurs (LED) solamente per gli accumulatori induttivi (LED)	45.48.26
--	----------

Induktiv-Ladegerät für Laryngoskope
Inductive Charging Device for Laryngoscopes
Cargador inductivo para laringoscopios
Chargeur inductif pour laryngoscopes
Ricaricatore induttivo per laringoscopi

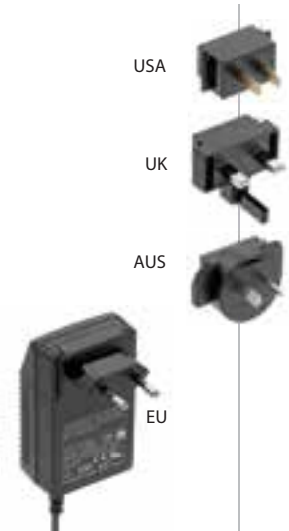

Keinesfalls batteriebetriebene Griffe laden.
Do not use inductive chargers for handles with batteries.
Nunca utilizar los cargadores inductivos para mangos con pilas.
Ne jamais utiliser les chargeurs inductifs pour les manches avec piles.
In nessun caso utilizzare i ricaricatori induttivi per caricare manici con batterie.



TREVALLi

Kunststoff-Etuis (leer) für Laryngoskope
Storage Cases (empty) for Laryngoscopes
Estuches de plástico (vacíos) para laringoscopios
Etuis en matière plastique (vides) pour laryngoscopes
Custodie (vuote) di plastica per laringoscopi

zur Lagerung von 4 Spatel, 1 Handgriff und Ersatzlampen
for storage of 4 blades, 1 handle and replacement lamps
para guardar 4 espátulas, 1 mango y lámparas de repuesto
pour le rangement de 4 spatules, d'un manche et de lampes de rechange
per riporre 4 lame, 1 manico e lampadine di ricambio



904.50.50

McINTOSH
45.15.61 - 64
45.17.61 - 64
45.01.11 - 14

904.50.52

McINTOSH
45.16.61 - 64

904.50.51

FOREGGER
45.25.61 - 64

MILLER
45.28.61 - 64
45.08.31 - 34

WIS-FOREGGER
45.05.11 - 14

Pediatric
45.29.60 - 62



TREVALLi

**Intubationszangen
Intubation Forceps
Pinzas de intubación
Pinces à intubation
Pinze per intubazione**



Magill
mod. Ehrensperger

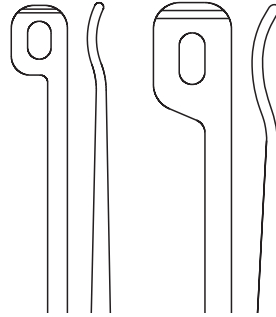

19 cm - 7 1/2" 24 cm - 9 1/2"

45.76.02 45.76.03

CHILDREN

ADULTS

mit atraumatischem Maul
with atraumatic jaws
con boca atraumática
avec mors atraumatiques
con morso atraumatico

für Erwachsene
for adults
para adultos
pour adultes
per adulti

für Kinder
for children
para niños
pour enfants
per bambini

für Kleinkinder
for infants
para niños pequeños
pour petits enfants
per bambini piccoli



Magill

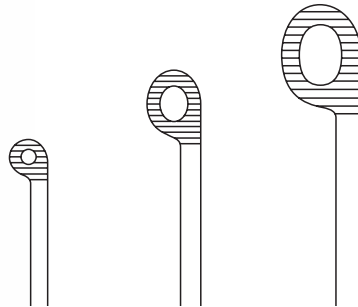

16 cm - 6 1/4" 19 cm - 7 1/2" 24 cm - 9 1/2"

45.75.01 45.75.02 45.75.03

INFANTS

CHILDREN

ADULTS



TREVALLi

Zungenzangen
Tongue Seizing Forceps
Pinzas tiralengua
Pinces tire-langue
Pinze tiralingua



45.82.17

Ersatz-Gummieinlagen (Paar)
Spare rubber inserts (pair)
Gomas de repuesto (par)
Mors en caoutchouc de rechange (paire)
Gommini di ricambio (paio)

1:1



17 cm - 6 $\frac{3}{4}$ "

45.81.17

Collin



16 cm - 6 $\frac{1}{4}$ "

45.82.16

Young



TREVALLi

**Sterilisierzangen, Instrumentenhalter
Sterilizing Forceps, Instrument Holder
Pinzas para esterilización, Porta-instrumentos
Pinces pour saisir les objets stérilisés, Plateau porte-instruments
Pinze per sterilizzazione, Sostegno portastrumenti**

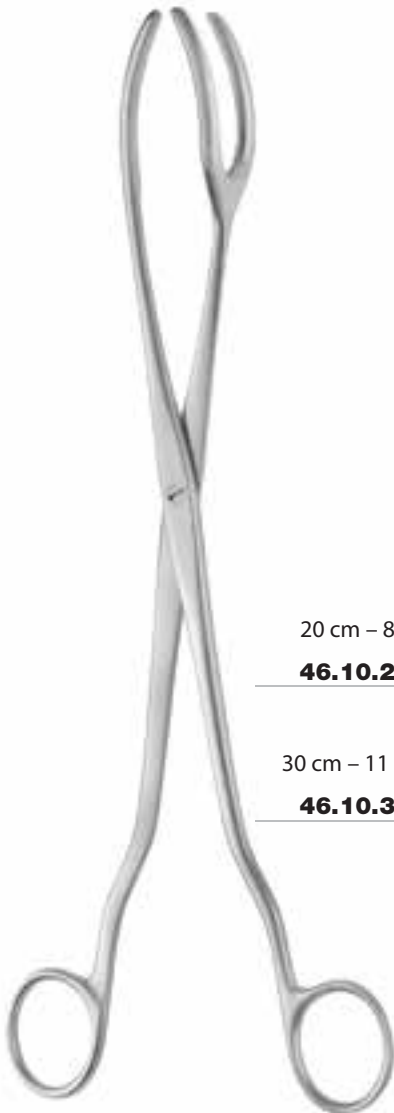

20 cm – 8"

46.10.20

30 cm – 11 3/4"

46.10.30



1:1

46.16.29

Ersatz-Gummieinlagen (Paar)
Spare rubber inserts (pair)
Gomas de repuesto (par)
Mors en caoutchouc de rechange (paire)
Gommini di ricambio (paio)



24 cm – 9 1/2"

46.16.24



46.29.50
Masing

1:3

Instrumentenhalter zur Ablage von
Instrumenten während der Operation

Instrument holder for placing instruments
during an operation

Porta-instrumentos para deponer los instrumentos
durante la operación

Plateau porte-instruments pendant l'opération

Sostegno portastrumenti per il deposito di
strumenti durante l'operazione



TREVALLi

**Euis
Cases
Estuches
Euis
Astucci**

230 × 130 × 50 mm

46.37.12



Siebschale, gelocht, mit abklappbaren seitlichen Griffen
Perforated tray, with folding lateral grips
Bandeja perforada, con mangos laterales plegable
Plateau perforé, à manches lateraux escamotables
Cestello perforato, con manici laterali rientranti

rostfreier 18/8 Stahl
18/8 stainless steel
acero inoxidable 18/8
acier inoxydable 18/8
acciaio inossidabile 18/8

Ø 65 mm × 15 mm

46.37.50



Nadeldose
Needle case
Estuche para agujas
Boîte à aiguille
Scatola per aghi



46.37.51

Innendose allein
Insert only
Caja interior sola
Boîte intérieure seule
Scatola interna sola

150 × 95 × 13 mm

46.37.65



Metalletui mit Trenneinteilung, ungelocht
Metal case with partition, non-perforated
Estuche de metal con compartimentos, no perforado
Boîte en métal compartimentée, non-perforée
Scatola metallica a scomparti, senza fori



TREVALLi

Etuis, Sterilisiergestell, Sterilisierbehälter
Cases, Sterilizing Rack, Sterilizing Cases
Estuches, Caballete para esterilizar, Cajas de esterilización
Etuis, Cadre de stérilisation, Boîtes de stérilisation
Astucci, Supporto per sterilizzazione, Scatole per sterilizzazione



190 × 97 × 32 mm

46.31.58

Sterilisier- und Lagerungsgestell für 8 Mikro-Rundgriff-Instrumente bis 17 cm Länge

Rack for sterilization and storage for 8 micro surgery instruments with round handles up to a length of 17 cm (6 ¾")

Caballete de esterilización y conservación para 8 micro instrumentos con mangos redondos hasta 17 cm de largo

Cadre de stérilisation et de rangement pour 8 instruments micro à manche rond, jusqu'à une longueur de 17 cm

Supporto per sterilizzazione e conservazione per 8 micro strumenti con manico rotondo fino a una lunghezza di 17 cm



200 × 100 × 20 mm

46.52.20

200 × 100 × 30 mm

46.52.30

200 × 100 × 40 mm

46.52.40

200 × 100 × 50 mm

46.52.50

Metalletuis, leer, mit Stülpedeckel und Schieberverschluss

Metal cases, empty, with lid and slide lock

Estuches de metal, vacíos, con tapa y cierre corredizo

Boîtes en métal, vides, avec couvercle et fermeture à coulisse

Scatole metallica, vuote, con coperchio sovrapposto e chiusura scorrevole

rostfreier 18/8 Stahl
18/8 stainless steel
acero inoxidable 18/8
acier inoxydable 18/8
acciaio inossidabile 18/8



Deckel gelocht – Boden gelocht
Lid perforated – Bottom perforated
Tapa perforada – Fondo perforado
Couvercle perforé – Fond perforé
Coperchio forato – Fondo forato



230 × 130 × 50 mm

46.55.23

260 × 150 × 50 mm

46.55.26

300 × 200 × 50 mm

46.55.30

325 × 275 × 50 mm

46.55.32

325 × 275 × 75 mm

46.55.34

mit auswechselbaren Textilfiltern und Scharnierdeckel mit Hebelverschluss

with exchangeable textile filters and hinged lid with lever lock

con filtros textiles cambiables y tapa con articulación de charnela con cierre de palanca

avec filtres textiles échangeables et couvercle à charnière avec fermeture à levier

filtri di stoffa cambiabili e coperchio a cerniera con chiusura e leva

Textilfilter allein
Textile filters only
Filtros textiles solos
Filtres textiles seuls
Filtri di stoffa soli

230 × 130 × 50 mm

46.56.23



260 × 150 × 50 mm

46.56.26



300 × 200 × 50 mm

46.56.30



325 × 275 × 50 mm

46.56.32



325 × 275 × 75 mm

46.56.32



Verpackungseinheit "X" Stück
Packing unit "X" pieces
Paquete de "X" unidades
Emballage de "X" pièces
Confezione da "X" pezzi



TREVALLi

**Trays für feine Instrumente
Trays for delicate Instruments
Bandejas para instrumentos delicados
Cassettes pour instruments délicats
Cassette per strumenti delicati**

Für eine schonende Aufbereitung und Lagerung von feinen und empfindlichen Instrumenten, wie z.B. mikrochirurgischen Instrumenten und feinen Häkchen. Die Trays können in Sterilisiercontainern, z.B. MEDICONTAINER, zusammen mit dem übrigen Instrumentarium sterilisiert und aufbewahrt werden.

For a careful sterilization and storage of fine and delicate instruments, for example micro surgery instruments and fine hooks. The trays may be sterilized and stored together with the instruments in sterilizing containers, for example MEDICONTAINER.

Para un tratamiento cuidadoso y para el almacenamiento de instrumentos delicados como p.ej. micro instrumentos y ganchitos finos. Las bandejas pueden ser esterilizadas y almacenadas en un contenedor para la esterilización, p.ej. los MEDICONTAINER.

Pour une préparation et un stockage avec ménagement d'instruments fins et délicats, comme p.ex. des instruments microchirurgicaux et des crochets fins. Les cassettes peuvent être stérilisées et rangées dans des containers de stérilisation comme p.ex. des MEDICONTAINER, ensemble avec d'autres instruments.

Per un'accurata preparazione ed un magazzino di strumenti delicati e fini, come p.e. strumenti per la microchirurgia ed uncini delicati. Le cassette possono essere sterilizzate e immagazzinate in contenitori per sterilizzazione, come p.e. i nostri MEDICONTAINER, insieme ad altri strumenti.



- ▶ autoklavierbar bis 134 °C bei 3 bar
- ▶ geringes Gewicht
- ▶ einfaches und sicheres Verschlussystem
- ▶ in leichter Kunststoffbauweise

- ▶ autoclavable up to 134 °C at 3 bar
- ▶ extremely light weight
- ▶ simple and secure locking system
- ▶ lightweight plastic construction

- ▶ autoclavable hasta 134 °C bajo presión de 3 bar
- ▶ peso muy ligero
- ▶ cierre fácil y seguro
- ▶ construcción ligera de material plástico

- ▶ autoclavable à 134 °C sous pression de 3 bars
- ▶ poids léger
- ▶ système de fermeture simple et sûr
- ▶ construction légère en matière plastique

- ▶ autoclavabile fino a 134 °C sotto pressione di 3 bar
- ▶ peso minimo
- ▶ sistema di chiusura facile e sicura
- ▶ costruzione leggera in materiale plastico



TREVALLi

Trays für feine Instrumente
Trays for delicate Instruments
Bandejas para instrumentos delicados
Cassettes pour instruments délicats
Cassette per strumenti delicati



190 × 102 × 19 mm

49.90.00

mit Silikonmatte, stapelbar
with silicone mat, stackable
con estera de silicona, apilable
avec tapis en silicone, empilable
con tappetino a grumelli, impilabile



280 × 170 × 55 mm

49.90.02

mit Silikonmatte
with silicone mat
con estera de silicona
avec tapis en silicone
con tappetino a grumelli

Tray für 12 Instrumente
Tray for 12 instruments
Bandeja para 12 instrumentos
Cassette pour 12 instruments
Cassetta per 12 strumenti



mit Haltestegen für festen und sicheren Halt
with holding device for a firm and safe storage
con dispositivo de fijación para una sujeción buena y segura
avec dispositif de fixation pour une fixation sûre
con dispositivo di fissazione per un fissaggio sicuro

203 × 114 × 30 mm

49.90.04



TREVALLi

Siebkörbe
Wire Baskets
Cestillas
Paniers grillagés
Cestelli a rete

Siebkörbe zur Lagerung und Sterilisation der Mikroinstrumente
Wire baskets for storage and sterilization of micro instruments
Cestillas para almacenamiento y esterilización de micro instrumentos
Paniers grillagés pour le rangement et la stérilisation d'instruments micro
Cestelli per magazzino e sterilizzazione di micro strumenti

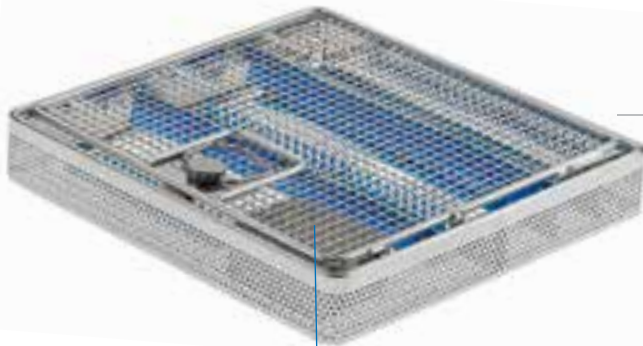

240 × 250 × 40 mm

49.97.90

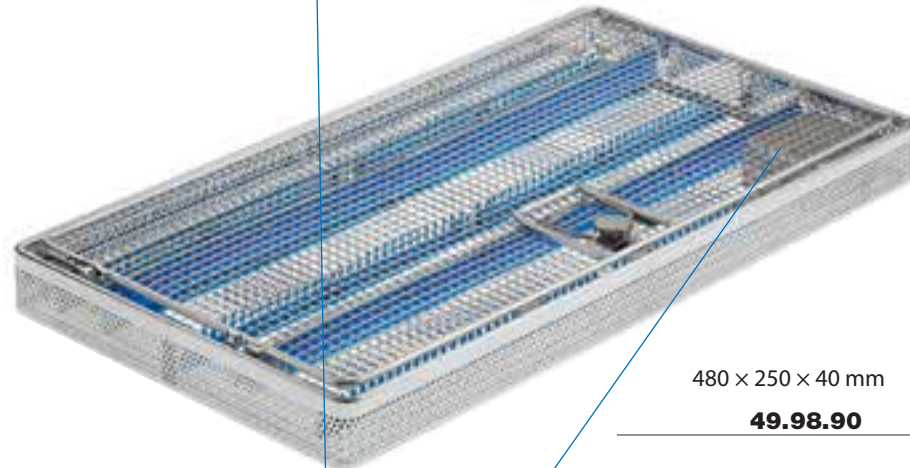

480 × 250 × 40 mm

49.98.90

- ▶ 4 variable Silikonmatten
- ▶ fest eingeschweißte Kleinteilebox
- ▶ zwei feste Y-Silikonprofile für Niederhaltefunktion
- ▶ verschleißbarer, abnehmbarer Deckel

- ▶ 4 variable silicone mats
- ▶ welded box for small parts
- ▶ two fixed Y-silicone profiles for holding down function
- ▶ lockable, detachable lid

- ▶ 4 esteras de silicona variables
- ▶ caja soldada firmemente para piezas pequeñas
- ▶ dos elementos Y de silicona para retener
- ▶ tapa desmontable con cerradura

- ▶ 4 tapis silicone variables
- ▶ boîte pour petites pièces solidement soudée
- ▶ deux profils Y en silicone pour fonction d'arrêt
- ▶ couvercle démontable fermant à clé

- ▶ 4 variabili tappettini in silicone
- ▶ box ben saldato per piccole parti
- ▶ 2 profili tipo Y in silicone per funzione di contenimento
- ▶ coperchio richiudibile e rimovibile

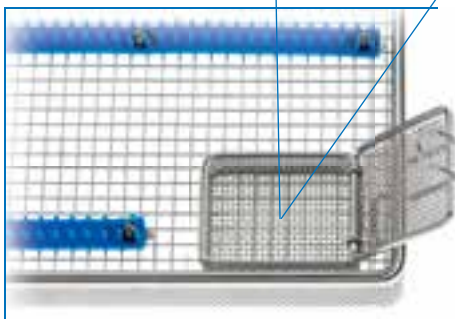

integrierte Kleinteilebox
integrated box for small parts
caja integrada para partes pequeñas
boîte pour petites pièces intégrée
box integrato per piccole parti



TREVALLi

Trays für Endoskope
Trays for Endoscopes
Bandejas para endoscopios
Cassettes pour endoscopes
Cassette per endoscopi

Siebkörbe zur Lagerung und Sterilisation der Endoskope
 Wire baskets for storage and sterilization of endoscopes
 Cestillas para almacenamiento y esterilización de endoscopios
 Paniers grillagés pour le rangement et la stérilisation des endoscopes
 Cestelli per magazzino e sterilizzazione di endoscopi

	49.97.04	49.97.06	49.97.05	49.97.07
	290 × 80 × 52 mm		460 × 80 × 52 mm	
Lagerung Endoskope Storage endoscopes Almacenamiento endoscopios Rangement d'endoscopes Magazzinaggio di endoscopi	1	2	1	2



445 × 85 × 50 mm

91.10.49

320 × 85 × 50 mm

77.60.49



Tray aus Kunststoff, zur Lagerung von 2 Optiken wie z.B. Sinuskope, Arthroskope (77.60.49) und Laparoskope (91.10.49) autoklavierbar bis 134 °C bei 3 bar

Plastic tray, for storage of 2 sinuscopes, arthroscopes (77.60.49) and laparoscopes (91.10.49) autoclavable up to 134 °C at 3 bar

Bandeja de plástico, para almacenar 2 ópticas como p. ej. sinuscopios, artroscopios (77.60.49) y laparoscopios (91.10.49) autoclavable hasta 134 °C bajo presión de 3 bar

Cassette en plastique, pour stockage de 2 optiques p. e. des sinuscopes, arthroscopes (77.60.49) et laparoscopes (91.10.49) autoclavable jusqu'à 134 °C sous pression de 3 bars

Cassetta di plastica, per il magazzino di 2 ottiche come p. es. sinuscopi, artroscopi (77.60.49) e laparoscopi (91.10.49) autoclavabile fino a 134 °C sotto pressione di 3 bar



TREVALLI

Schalen, Gefäße
Bowls, Jars
Cubetas, Recipientes
Cuvettes, Réipients
Scodelle, Recipienti



170 × 95 × 35 mm

47.20.17

200 × 95 × 40 mm

47.20.20

250 × 140 × 35 mm

47.20.25

270 × 150 × 40 mm

47.20.27

Nierenschalen
Kidney bowls
Riñoneras
Haricots
Bacinelle reniformi



210 × 155 × 17 mm

47.26.19

240 × 160 × 17 mm

47.26.24

280 × 140 × 10 mm

47.26.28

295 × 195 × 17 mm

47.26.29

315 × 215 × 14 mm

47.26.32

395 × 275 × 10 mm

47.26.38

rostfreier 18/8 Stahl
18/8 stainless steel
acero inoxidable 18/8
acier inoxydable 18/8
acciaio inossidabile 18/8



TREVALLi

**Schalen, Gefäße
Bowls, Jars
Cubetas, Recipientes
Cuvettes, Récipients
Scodelle, Recipienti**

Rundschalen (Lösungsschalen)
Round bowls (for liquids)
Cubetas (para líquidos)
Cupules rondes (pour liquide)
Scodelle tonde (per liquido)



80 × 35 mm · 0,10 l

47.30.08

95 × 50 mm · 0,20 l

47.30.09

105 × 60 mm · 0,30 l

47.30.10

130 × 70 mm · 0,50 l

47.30.13



40 × 20 mm · 0,02 l

47.31.01

60 × 30 mm · 0,06 l

47.31.02

80 × 40 mm · 0,16 l

47.31.04

110 × 55 mm · 0,40 l

47.31.06

150 × 75 mm · 1,00 l

47.31.08

210 × 95 mm · 2,50 l

47.31.10

Wattespender
Cotton dispenser
Distribuidor de algodón
Distributeur de coton
Contentitore per cotone



Ø 50 × 75 mm

330.20.00

Methot

rostfreier 18/8 Stahl
18/8 stainless steel
acero inoxidable 18/8
acier inoxydable 18/8
acciaio inossidabile 18/8

Standgefäße
Jars
Recipientes
Récipients
Recipienti



30 × 95 mm

47.40.03

50 × 100 mm

47.40.04

50 × 130 mm

47.40.05

50 × 175 mm

47.40.06

85 × 180 mm

47.40.07

85 × 130 mm

47.40.08

100 × 200 mm

47.40.12



TREVALLi

ENT INSTRUMENTS

Otologie
Otology
Otología
Otologie
Otologia

www.techronsurgical.com



TREVALLI

Ohrspekula, Zubehör
Ear Specula, Accessories
Espéculos auriculares, Accesorios
Spéculums auriculaires, Accessoires
Specoli auricolari, Accessori



Brünings

Pneumatisches Ohrspekulum, komplettes Besteck mit Lupe und Gebläse, in Holzetui
Pneumatic ear speculum, complete set with lens and rubber bulb, in wooden case
Espéculo auricular neumático, estuche completo con lupa y pera de goma, en estuche de madera
Spéculum auriculaire pneumatique, trousse complète comprenant loupe et soufflerie, dans une boîte en bois
Specolo auricolare pneumatico, set completo di lente in astuccio di legno

62.00.10	4 Spekula Fig.1 – 4
	4 specula fig. 1 – 4
	4 espéculos fig. 1 – 4
	4 spéculums fig. 1 – 4
62.00.11	6 Spekula Fig.0 – 5
	6 specula fig. 0 – 5
	6 espéculos fig. 0 – 5
	6 spéculums fig. 0 – 5
	6 specoli fig. 0 – 5

Optionales Zubehör
Optional accessories
Accesorios opcionales
Accessoires optionnels
Accessori opzionali



Schlaucholive allein
Tubing connector
Oliva de tubos
Raccord olivaire
Raccordo olivare



1:1 **906.20.03**

Etui allein
Case only
Estuche solo
Boîte seul
Astuccio solo



906.20.16



TREVALLI

**Ohrspekula, Zubehör
Ear Specula, Accessories
Espéculos auriculares, Accesorios
Spéculums auriculaires, Accessoires
Specoli auricolari, Accessori**



62.00.20	# 0	Ø 5,5 mm
62.00.21	# 1	Ø 6,5 mm
62.00.22	# 2	Ø 7,5 mm
62.00.23	# 3	Ø 8,5 mm
62.00.24	# 4	Ø 9,5 mm
62.00.25	# 5	Ø 10,5 mm

Zubehör
Accessories
Accesorios
Accessoires
Accessori



Lupe allein, volles Fenster, mit Schlaucholive
Magnifier only, full lens, with tubing connector
Lupa sola, con lente piena, con oliva de tubos
Loupe seule, fenêtre pleine, avec raccord olivaire
Lente sola, finestra piena, con raccordo olivare



**62.00.13
Brünings**

Lupe allein, Segment-Ausschnitt
Magnifier only, segmented lens
Lupa sola, sector segmentado
Loupe seule, secteur segmenté
Lente sola, settore segmentato



**62.00.14
Brünings**

Gummi-Gebläse allein, passend für BRÜNING'S Lupen
Rubber bulb only, fitting the BRÜNING'S magnifiers
Pera de goma sola, apropiada para las lupas según BRÜNING'S
Soufflerie en caoutchouc seule, pour les loupes de BRÜNING'S
Soffiatrice di gomma sola, adatta per le lenti di BRÜNING'S



62.00.15

Außendurchmesser
Outer diameter
Diámetro exterior
Diamètre extérieur
Diametro esterno



TREVALLi

Ohrspekula, Zubehör
Ear Specula, Accessories
Espéculos auriculares, Accesorios
Spéculums auriculaires, Accessoires
Specoli auricolari, Accessori

für Kinder
 for children
 para niños
 pour enfants
 per bambini



Hartmann

verchromt chrome-plated cromado chromé cromato				Rostfreier Edelstahl Stainless steel Acero inoxidable Acier inoxydable Acciaio inossidabile
62.01.00	Satz zu 3 Stück # 1 - 3 Set of 3 pieces # 1 - 3 Juego de 3 piezas # 1 - 3 Jeu de 3 pièces # 1 - 3 Serie di 3 pezzi # 1 - 3			62.02.00
62.01.01	Ø 3,0 mm	# 1	Ø 3,0 mm	62.02.01
62.01.02	Ø 4,5 mm	# 2	Ø 4,0 mm	62.02.02
62.01.03	Ø 5,5 mm	# 3	Ø 5,0 mm	62.02.03

für Erwachsene
 for adults
 para adultos
 pour adultes
 per adulti



Hartmann

verchromt chrome-plated cromado chromé cromato				Rostfreier Edelstahl Stainless steel Acero inoxidable Acier inoxydable Acciaio inossidabile
62.01.10	Satz zu 3 Stück # 1 - 3 Set of 3 pieces # 1 - 3 Juego de 3 piezas # 1 - 3 Jeu de 3 pièces # 1 - 3 Serie di 3 pezzi # 1 - 3			62.02.10
62.01.11	Ø 5,5 mm	# 1	Ø 5,0 mm	62.02.11
62.01.12	Ø 6,5 mm	# 2	Ø 6,0 mm	62.02.12
62.01.13	Ø 7,5 mm	# 3	Ø 7,5 mm	62.02.13

für Erwachsene
 for adults
 para adultos
 pour adultes
 per adulti



Toynbee

verchromt chrome-plated cromado chromé comato				Rostfreier Edelstahl Stainless steel Acero inoxidable Acier inoxydable Acciaio inossidabile
62.01.30	Satz zu 3 Stück # 2 - 4 Set of 3 pieces # 2 - 4 Juego de 3 piezas # 2 - 4 Jeu de 3 pièces # 2 - 4 Serie di 3 pezzi # 2 - 4			62.02.30
62.01.37	Ø 5,5 mm	# 2	Ø 5,5 mm	62.02.37
62.01.38	Ø 6,5 mm	# 3	Ø 6,5 mm	62.02.38
62.01.39	Ø 7,5 mm	# 4	Ø 7,5 mm	62.02.39

Ø = Außendurchmesser
 Outer diameter
 Diámetro exterior
 Diamètre extérieur
 Diametro esterno



TREVALLi

für Erwachsene
for adults
para adultos
pour adultes
per adulti



Toynbee

verchromt chrome-plated cromado chromé cromato				Rostfreier Edelstahl Stainless steel Acero inoxidable Acier inoxydable Acciaio inossidabile
62.01.31	Satz zu 4 Stück # 1 - 4 Set of 4 pieces # 1 - 4 Juego de 4 piezas # 1 - 4 Jeu de 4 pièces # 1 - 4 Serie di 4 pezzi # 1 - 4			62.02.31
62.01.36	Ø 4,5 mm	# 1	Ø 4,5 mm	62.02.36
62.01.37	Ø 5,5 mm	# 2	Ø 5,5 mm	62.02.37
62.01.38	Ø 6,5 mm	# 3	Ø 6,5 mm	62.02.38
62.01.39	Ø 7,5 mm	# 4	Ø 7,5 mm	62.02.39

für Erwachsene
for adults
para adultos
pour adultes
per adulti



Boucheron

62.01.61	Satz zu 4 Stück # 1 - 4 Set of 4 pieces # 1 - 4 Juego de 4 piezas # 1 - 4 Jeu de 4 pièces # 1 - 4 Serie di 4 pezzi # 1 - 4			Ø = Außendurchmesser Outer diameter Diámetro exterior Diamètre extérieure Diametro esterno	
62.01.66	# 1	Ø 4,5 mm	62.01.68	# 3	Ø 6,5 mm
62.01.67	# 2	Ø 5,5 mm	62.01.69	# 4	Ø 7,5 mm



Zöllner

62.03.00	Satz zu 6 Stück # 1 - 6 Set of 6 pieces # 1 - 6 Juego de 6 piezas # 1 - 6 Jeu de 6 pièces # 1 - 6 Serie di 6 pezzi # 1 - 6			Ø = Innendurchmesser Inside diameter Diámetro interior Diamètre intérieur Diametro interno	
62.03.11	# 1	5,5 × 6,5 mm	62.03.14	# 4	8,5 × 9,5 mm
62.03.12	# 2	6,5 × 7,5 mm	62.03.15	# 5	9,5 × 10,5 mm
62.03.13	# 3	7,5 × 8,5 mm	62.03.16	# 6	10,5 × 11,5 mm



TREVALLi

Ohrspekula, Zubehör
Ear Specula, Accessories
Espéculos auriculares, Accesorios
Spéculums auriculaires, Accessoires
Specoli auricolari, Accessori



Delrin*

62.01.90

Satz zu 6 Stück
Set of 6 pieces
Juego de 6 piezas
Jeu de 6 pièces
Serie di 6 pezzi

62.01.92

Ø 2 mm

62.01.95

Ø 5 mm

62.01.93

Ø 3 mm

62.01.96

Ø 6 mm

62.01.94

Ø 4 mm

62.01.97

Ø 7 mm

* Kunststoff (Delrin), schwarz, abgeschrägte Trichteröffnung, sterilisierbar
Plastic (Delrin), black, bevelled opening of funnel, autoclavable
De materia plástica (Delrin), negro, orificio en forma de embudo, esterilizable
En matière plastique (Delrin), noir, à orifice chanfreiné, stérilisable
In materia plastica (Delrin), nero, apertura obliqua, sterilizzabile



110 × 85 mm

62.03.65

Sterilisier- und Lagerungsgestell für 12 Ohrspekula
Sterilizing and storage rack for 12 ear specula
Soporte de esterilización de conservación para 12 espéculos auriculares
Support de stérilisation et de conservation pour 12 spéculums auriculaires
Sostegno per sterilizzare e magazzinare 12 specoli auricolari



TREVALLI

Ohrspekula, Zubehör
Ear Specula, Accessories
Espéculos auriculares, Accesorios
Spéculums auriculaires, Accessoires
Specoli auricolari, Accessori

Ohrspekulahalter zur Befestigung am Kopfbügel oder der Stange des Operationstisches
Articulated arm for fixation of ear specula to the head bow or the bar of the operating table
Fijador de espéculos auriculares, para fijar al estribo de cabeza o a barra de la mesa quirúrgica
Collier porte-spéculums auriculaires pour fixation au ressort de tête ou à la barre de la table d'opération
Portaspecolo auricolare, fissabile al poggiatesta o sull'asta del tavolo operatorio

1 flexibler Spannarm Nr. 57.59.10
1 flexible clamping arm No. 57.59.10
1 brazo tensor flexible No. 57.59.10
1 bras articulé flexible No. 57.59.10
1 braccio di fissaggio flessibile No. 57.59.10

1

1 Schraubzwinge Nr. 57.59.26
1 screw clamp No. 57.59.26
1 tornillo de apriete No. 57.59.26
1 serre-joint No. 57.59.26
1 morsetto a vite No. 57.59.26

2

1 Ohrspekula-Haltezange Nr. 62.03.86
1 holding clamp for ear specula no. 62.03.86
1 pinza de sujeción para espéculos auriculares No. 62.03.86
1 clamp de serrage pour spéculums auriculaires No. 62.03.86
1 pinza portaspecoli auricolari No. 62.03.86

3

Set
62.03.85

Leyla

komplette Ausstattung bestehend aus:
complete set consisting of:
equipo completo compuesto de:
garniture complète composée de:
attrezzatura completa composta da:





TREVALLi

**Ohrspekula, Zubehör
Ear Specula, Accessories
Espéculos auriculares, Accesorios
Spéculums auriculaires, Accessoires
Specoli auricolari, Accessori**



Ø 6 mm

62.04.11

1



Ø 7 mm

62.04.12

2

Holmgren



Ø 3 mm

62.04.40

0



Ø 4 mm

62.04.41

1



Ø 5 mm

62.04.42

2



Ø 6 mm

62.04.43

3

Richnau-Holmgren



13 cm – 5 1/8"

62.04.75

Paparella

Ø = | Außendurchmesser
Outer diameter
Diámetro exterior
Diamètre extérieure
Diametro esterno



TREVALLI

Stimmgabelbesteck zu 5 Stück, in Etui
 Set of 5 tuning forks, in case
 Juego de 5 diapasones, en estuche
 Jeu de 5 diapasons, en étui
 Serie di 5 diapason, in astuccio



62.05.05
Hartmann

Stimmgabeln
Tuning Forks
Diapasones
Diapasons
Diapason

bestehend aus:
 consisting of:
 compuesto de:
 se composant de:
 composto da:

62.05.60	c - 128
62.05.61	c ¹ - 256
62.05.12	c ² - 512
62.05.13	c ³ - 1024
62.05.14	c ⁴ - 2048



Hartmann

62.05.10	c - 128
62.05.11	c ¹ - 256
62.05.12	c ² - 512
62.05.13	c ³ - 1024
62.05.14	c ⁴ - 2048
62.05.15	c ⁵ - 4096



Lucae

62.06.10	c - 128
62.06.11	c ¹ - 256
62.06.12	c ² - 512



Hartmann

62.05.59	C - 64
62.05.60	c - 128
62.05.61	c ¹ - 256



62.06.36 | a¹ - 440



TREVALLI

**Stimmgabeln
Tuning Forks
Diapasones
Diapasons
Diapason**



French

62.05.32 | C₁ - 32



Rydel-Seiffer

906.20.15	Schraube allein Screw only Tornillo solo Vis seule Vite solo	1
906.20.02	Dämpfer allein, links Mute only, left Sordina sola, izquierda Curseur seul, gauche Cursore solo, sinistra	2
906.20.01	Dämpfer allein, rechts Mute only, right Sordina sola, derecha Curseur seul, droit Cursore solo, destra	3

62.06.50 | C - 64 / c - 128

Dämpfer abnehmbar,
mit Dämpfer C 64,
ohne Dämpfer c 128

with removable mute,
with mute C 64,
without mute c 128

sordina desmontable,
con sordina C 64,
sin sordina c 128

à curseur amovible,
avec curseur C 64 vibr.,
sans curseur c 128 vibr.

cursori smontabili,
con cursori C 64,
senza cursori c 128



TREVALLi

**Stimmgabeln
Tuning Forks
Diapasones
Diapasons
Diapason**

c
d
e
f
g
a
h

c 128, mit Dämpfer, einstellbar bis h
c 128, with mute, adjustable up to h
c 128, con sordina, ajustable hasta h
c 128 vibr., avec curseur, réglable jusqu'à h
c 128, con cursori, regolabili fino a h

62.06.70 | c - 128

Lucae

A
H
c
d
e
f
g

A 109, mit Dämpfer, einstellbar bis g
A 109, with mute, adjustable up to g
A 109, con sordina, ajustable hasta g
A 109 vibr., avec curseur, réglable jusqu'à g
A 109, con cursori, regolabili fino a g

62.06.80 | A - 109

König

Stimmgabeln aus Aluminium-Speziallegierung
Tuning forks made of special aluminium alloy
Diapasones de aleación especial de aluminio
Diapasons en alliage spécial d'aluminium
Diapason in lega speciale d'alluminio

62.07.11 | c¹ - 256

62.07.10 | c - 128



TREVALLi

Lärmtrommel, Hörschlauch
Noise Box, Auricular tube
Tambor ensordecedor, Tubo auricular
Assourdisseur, Tube auriculaire
Assordatore, Tubo auricolare

62.09.03



Hartgummi-Olive allein
Hard rubber olive only
Oliva de ebonita, solo
Olive en ébonite, seule
Oliva di ebanite, sola

62.09.02

mit Hartgummi-Ohrolive
with hard rubber ear olive
con oliva de ebonita
avec olive en ébonite
con oliva auricolare di ebanite

Barany



62.09.50



Jansen

Hörschlauch, komplett mit:
Auricular tube complete with:
Tubo auricular, completo con:
Tube auriculaire, complet avec:
Tubo auricolare, completo con:

1 schwarzen Arztolive, 6 Patientenoliven (je 2 × # 1 – 3), mit Ständer für Oliven
1 black physician ear olive, 6 patient ear olives (2 ea. # 1 – 3), with rack for ear olives
1 oliva negra para el médico, 6 olivas para los pacientes (2 de cada # 1 – 3), con caballete para olivas
1 olive noire pour le médecin, 6 olives pour le patient (# 1 – 3, 2 pièces de chaque modèle), avec cadre de rangement pour les olives
1 oliva nera per il medico, 6 olive per il paziente (2 cad. × # 1 – 3), con sostegno per olive



TREVALLi

**Luftdusche
Insufflator
Insuflador de aire
Douche à air
Insufflatore**



62.20.69 **5**

Zwischenstück allein, ohne Nasenolive
Connecting piece only, without nasal olive
Pieza intermedia solo, sin oliva nasal
Pièce intermédiaire seule, sans olive nasale
Connettore intermedio solo, senza oliva nasale

62.20.55 **1**

Gummi-Birne allein
Rubber bulb only
Pera de goma sola
Poire en caoutchouc seule
Pera di gomma sola

62.20.50
Politzer



Ø 15 mm **2**
62.20.62

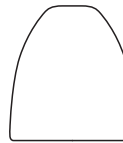

Ø 17 mm **3**
62.20.63

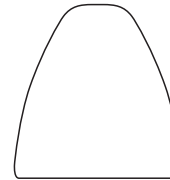

Ø 22 mm **4**
62.20.64

Luftdusche, komplett, bestehend aus:
Insufflator, complete, consisting of:
Insuflador de aire, completo, compuesto de:
Douche à air, complète, se composant de:
Insufflatore, completo, composta da:

1 Gummi-Birne Nr. 62.20.55
1 Rubber bulb No. 62.20.55
1 Pera de goma No. 62.20.55
1 Poire en caoutchouc No. 62.20.55
1 Pera di gomma No. 62.20.55

1



1 Nasenolive Nr. 62.20.62
1 Nasal olive No. 62.20.62
1 Oliva nasal No. 62.20.62
1 Olive nasale No. 62.20.62
1 Oliva nasale No. 62.20.62

2



1 Nasenolive Nr. 62.20.63
1 Nasal olive No. 62.20.63
1 Oliva nasal No. 62.20.63
1 Olive nasale No. 62.20.63
1 Oliva nasale No. 62.20.63

3



1 Nasenolive Nr. 62.20.64
1 Nasal olive No. 62.20.64
1 Oliva nasal No. 62.20.64
1 Olive nasale No. 62.20.64
1 Oliva nasale No. 62.20.64

4



1 Zwischenstück Nr. 62.20.69
1 Connecting piece No. 62.20.69
1 Pieza intermedia No. 62.20.69
1 Pièce intermédiaire No. 62.20.69
1 Connettore No. 62.20.69

5





TREVALLi

Ohrspritzen
Ear Syringes
Jeringas para el oído
Seringues auriculaires
Siringhe auricolari



50 ml
62.24.05

75 ml
62.24.07

100 ml
62.24.10

Ganzmetall-Ohrspritze
All metal ear syringe
Jeringa para el oído, todo metal
Seringue auriculaire, tout métal
Siringa auricolare, interamente in metallo

komplett mit 2 Aufsätzen und 1 Schutzteller, mit Luer-Lock-Ansatz
complete with 2 attachments and 1 protecting plate, with Luer-Lock cone
completa con 2 piezas sobrepuestas y 1 platillo protector, con cono Luer-Lock
complète avec 2 embouts et assiette protectrice, avec cône Luer-Lock
completa di 2 attacchi e 1 piatto protettore con cono Luer-Lock

Ersatzteile
Spare parts
Piezas de repuesto
Pièces de rechange
Pezzi di ricambio



Aufsatz allein, konisch, mit Luer-Lock-Ansatz
Conical attachment only, with Luer-Lock cone
Pieza sobrepuesta, sola, cónica, con cono Luer-Lock
Embout, seul, conique, avec cône Luer-Lock
Attacco, solo, conico, con cono Luer-Lock



62.24.16

Aufsatz allein, olivenförmig, mit Luer-Lock-Ansatz
Olive-shaped attachment only, with Luer-Lock cone
Pieza sobrepuesta, sola, forma de oliva, con cono Luer-Lock
Embout, seul, olivaire, avec cône Luer-Lock
Attacco, solo, olivare, con cono Luer-Lock



62.24.17

Schutzteller allein, Ø 58 mm, mit Luer-Lock-Ansatz
Protective plate only, Ø 58 mm, with Luer-Lock cone
Platillo protector, solo, Ø 58 mm, con cono Luer-Lock
Assiette protectrice, seule, Ø 58 mm, avec cône Luer-Lock
Piatto protettore, solo, Ø 58 mm, con cono Luer-Lock



62.24.19



TREVALLi

Pulverbläser
Powder Blower
Pulverizador
Pulvérisateur
Polverizzatore



Kabierske

30 ml

62.28.00

Pulverbläser
Powder blower
Pulverizador
Pulvérisateur
Polverizzatore

komplett mit je 1 Kanüle Nr. 62.28.16-18
complete with 1 cannula ea. No. 62.28.16-18
completo con 1 cánula de cada uno de los No. 62.28.16-18
complet avec 1 canule de chacun des No. 62.28.16-18
completo di 1 cannula No. 62.28.16-18

Ersatzteile
Spare parts
Piezas de repuesto
Pièces de rechange
Pezzi di ricambio



Ersatz-Glasbehälter, 30 ml
Spare glass bottle, 30 ml
Recipiente de vidrio de repuesto, 30 ml
Réceptient de rechange, en verre, 30 ml
Recipiente di vetro di ricambio, 30 ml



62.28.10

Metall-Aufsatz mit Ventilball
Metal cap with rubber bulb
Pieza sobrepuesta con pera valvular
Embout métallique avec poire à soupape
Attacco metallico con pera e valvola



62.28.11

Ventilball allein
Rubber bulb only
Pera de goma con válvula, sola
Poire à soupape, seule
Pera di gomma con valvola, sola



62.28.12

Ohrkanüle allein
Ear cannula only
Cánula auricular, sola
Canule auriculaire, seule
Cannula auricolare, sola



62.28.16
8 cm - 3 1/8"

Nasenkanüle allein
Nasal cannula only
Cánula nasal, sola
Canule nasale, seule
Cannula nasale, sola



62.28.17
11 cm - 4 3/8"

Kehlkopfkanüle allein
Laryngeal cannula only
Cánula laríngeal, sola
Canule laryngienne, seule
Cannula laringea, sola



62.28.18
13 cm - 5 1/8"



TREVALLi

Ohrpolypenschnürer
Ear Polypus Snares
Polipotomos auriculares
Serre-noeud pour polyps auriculaires
Serranodi auricolari



16 cm – 6 1/4"

62.10.10

Krause



16 cm – 6 1/4"

62.10.30

Wilde



Ø 0,2 mm Ø 0,3 mm
62.10.42 **62.10.43**

Schnürerdrähte
Snare wires
Alambres para cierranudos
Fils pour serre-noeud
Fili per serranodi

Rolle zu 10 Meter
Coil 10 m (33.3 ft.)
Rollo de 10 m
Rouleau de 10 m
Rotolo da 10 m



Ø 0,2 mm Ø 0,3 mm
62.10.47 **62.10.48**

Schnürerdrähte, vorgeformt
Snare wires, preshaped
Alambres para cierranudos, preformadas
Fils pour serre-noeud, préformées
Fili per serranodi, preformati

Bündel zu 100 Stück
Bundle of 100 pieces
Lio de 100 piezas
Botte de 100 pièces
Confezione da 100 pezzi



TREVALLI

Saug- und Spülinstrumente
Aspirating and Irrigating Instruments
Instrumentos de aspiración y de lavado
Instrumenti à aspiration et à irrigation
Strumenti per aspirazione e lavaggio



62.21.01	Ø 0,7 × 80 mm
62.21.02	Ø 0,9 × 80 mm
62.21.03	Ø 1,2 × 80 mm

Luer-Lock ♀

Rosen



62.22.10	Ø 1,0 × 75 mm
62.22.15	Ø 1,5 × 75 mm
62.22.20	Ø 2,0 × 75 mm

Baron (Schuknecht)

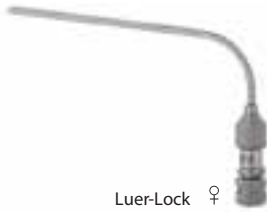

Luer-Lock ♀

Rosen

62.21.11	Ø 0,7 × 65 mm
62.21.12	Ø 0,9 × 65 mm
62.21.13	Ø 1,2 × 65 mm
62.21.14	Ø 1,5 × 65 mm
62.21.15	Ø 2,0 × 65 mm

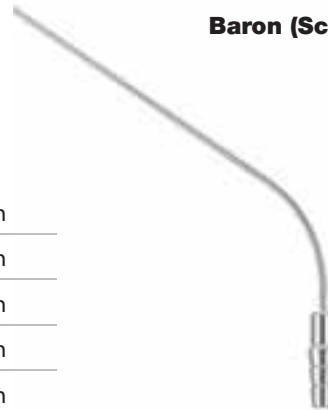

62.22.01	Ø 1,0 × 90 mm
62.22.02	Ø 1,5 × 90 mm
62.22.03	Ø 2,0 × 90 mm

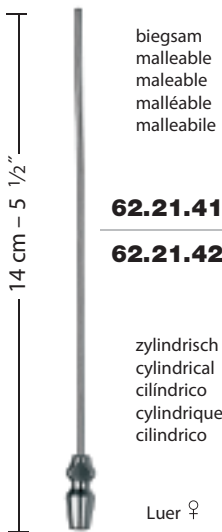

biegsam
malleable
maleable
malléable
malleabile

62.21.41	Ø 1,5 × 120 mm
62.21.42	Ø 2,0 × 120 mm

zylindrisch
cylindrical
cilindrico
cylindrique
cilindrico

Luer ♀

Wullstein

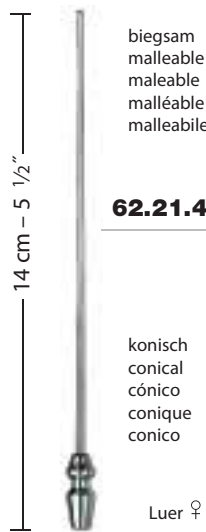

biegsam
malleable
maleable
malléable
malleabile

62.21.43	Ø 1,5 × 120 mm
-----------------	----------------

konisch
conical
cónico
conique
conico

Luer ♀

Wullstein



62.21.48

Schlauchverbindungsstück, passend für ROSEN und WULLSTEIN Saugröhrchen

Tube connector, suitable for ROSEN and WULLSTEIN suction tubes

Pieza de unión para tubo, apropiada para los tubitos aspiradores según ROSEN y WULLSTEIN

Raccord-tuyaux, pour tubes aspirateurs de ROSEN et WULLSTEIN

Raccordo per tubo, per cannule per aspirazione di ROSEN e WULLSTEIN



TREVALLI

Saug- und Spülinstrumente
Aspirating and Irrigating Instruments
Instrumentos de aspiración y de lavado
Instruments à aspiration et à irrigation
Strumenti per aspirazione e lavaggio



Luer

Wullstein

62.21.46

Spül- und Saughandgriff, passend für ROSEN und WULLSTEIN Spül- und Saugrohre

Irrigating and aspirating suction handle, for ROSEN and WULLSTEIN irrigation and suction tubes

Mango irrigador y aspirador, para los tubos de lavado y de aspiración según ROSEN y WULLSTEIN

Manche aspirateur et irrigateur, s'adaptant aux tubes aspirateurs/irrigateurs de ROSEN et WULLSTEIN

Manico per aspirazione e lavaggio, per cannule per aspirazione e lavaggio di ROSEN e WULLSTEIN



62.22.61 # 1 Ø 1,7 mm × 190 mm

62.22.62 # 2 Ø 2,0 mm × 190 mm

Nutzlänge 11 cm
Working length 11 cm – 4 3/8"
Largo útil 11 cm
Longueur utile 11 cm
Lunghezza utile 11 cm

Frazier (Fergusson)



Luer

Zöllner

62.22.30

Absaugröhrchen mit Griffplatte
Suction tube with finger plate
Tubito de succión, con mango rectangular plano
Tube aspirateur à appui-doigt
Cannula per aspirazione con appoggiadita

komplett mit 1 aufsetzbaren Kanüle Nr. 62.22.37
complete with 1 slip-on cannula No. 62.22.37
completo con 1 cánula desmontable No. 62.22.37
complet avec 1 canule démontable No. 62.22.37
completa di 1 cannula applicabile No. 62.22.37

62.22.31

Saugrohr allein (ohne Kanüle)
Aspirating tube only (without cannula)
Tubo aspirador solo (sin cánula)
Tube à aspiration, seul (sans canule)
Cannula aspiratrice, sola (senza cannula)

Aufsetzbare Mikro-Saugkanüle allein
Slip-on micro suction cannula only
Micro cánula aspiradora, sola
Micro canule aspiratrice démontable, seule
Micro cannula aspiratrice applicabile, sola

62.22.35 Ø 0,5 mm

62.22.37 Ø 0,7 mm

Nutzlänge 3 cm
Working length 3 cm – 1 1/8"
Largo útil 3 cm
Longueur utile 3 cm
Lunghezza utile 3 cm



Zöllner



TREVALLi

Saug- und Spülinstrumente
Aspirating and Irrigating Instruments
Instrumentos de aspiración y de lavado
Instrumenti à aspirazione et à irrigation
Strumenti per aspirazione e lavaggio



62.22.71 # 1

für das rechte Ohr
for the right ear
para oído recto
pour oreille droite
per orecchio destro

Hartmann



62.22.72 # 2

für das linke Ohr
for the left ear
para oído izquierdo
pour oreille gauche
per orecchio sinistro

Hartmann

Nutzlänge 3 cm
Working length 3 cm – 1 1/8"
Largo útil 3 cm
Longueur utile 3 cm
Lunghezza utile 3 cm



62.23.09 # 1 Ø 0,9 + 0,7 mm

62.23.12 # 2 Ø 1,2 + 0,9 mm

62.23.15 # 3 Ø 1,5 + 1,2 mm

Nutzlänge 9 cm
Working length 9 cm – 3 1/2"
Largo útil 9 cm
Longueur utile 9 cm
Lunghezza utile 9 cm

House

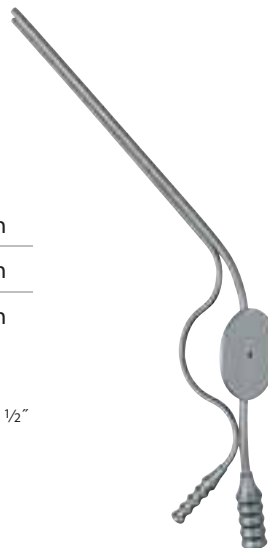

62.23.18 Ø 1,8 + 1,8 mm

62.23.25 Ø 2,5 + 2,0 mm

62.23.30 Ø 3,0 + 2,0 mm

62.23.45 Ø 4,5 + 2,0 mm

Nutzlänge 9 cm
Working length 9 cm – 3 1/2"
Largo útil 9 cm
Longueur utile 9 cm
Lunghezza utile 9 cm



TREVALLi

Raspatorien, Elevatorien
Raspatories, Elevators
Legras, Elevadores
Rugines, Elévateurs
Periostotomi, Elevatori



62.60.52

62.60.57

62.60.58

Lempert

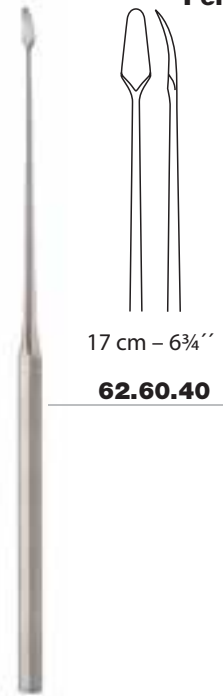

17 cm - 6 3/4"

62.60.40

Wullstein



15 mm

17 cm - 6 3/4"

62.60.80

Jansen



6 mm

6 mm

18 cm - 7 1/8"

18 cm - 7 1/8"

62.60.70

62.60.71

Lempert



TREVALLI

Knochenstanzen
Mastoid Rongeurs
Pinzas cortantes para huesos
Pinces emporte-pièce pour os
Pinze ossivore



Kerrison

			b
	62.62.03	# 0	3 mm
	62.62.04	# 1	4 mm
	62.62.05	# 2	5 mm
	62.62.06	# 3	6 mm

Attikusstanzen
Atticus punches
Pinzas cortantes para el ático
Pinces emporte-pièces pour l'attique
Pinze taglianti per l'attico

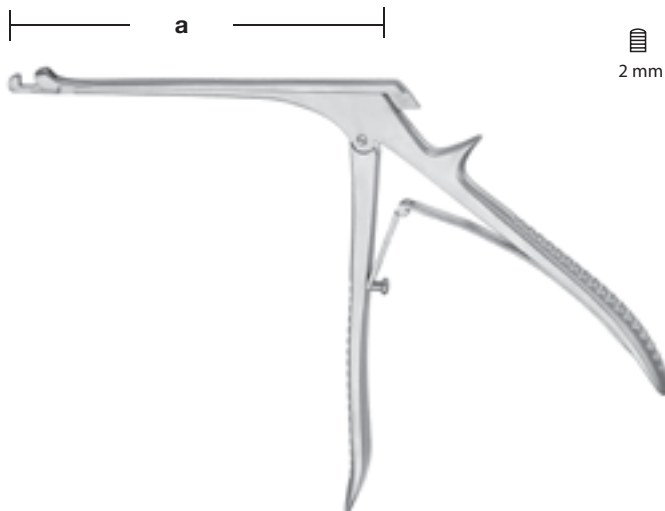

Beyer

		a
	62.62.72	9,5 cm - 3 3/4"
	62.62.73	17 cm - 6 3/4"

durchschneidend
through-cutting
cortante
coupant
tagliante



TREVALLI

Knochenstanzen
Mastoid Rongeurs
Pinzas cortantes para huesos
Pinces emporte-pièce pour os
Pinze ossivore

durchschneidend
through-cutting
cortante
coupant
tagliante

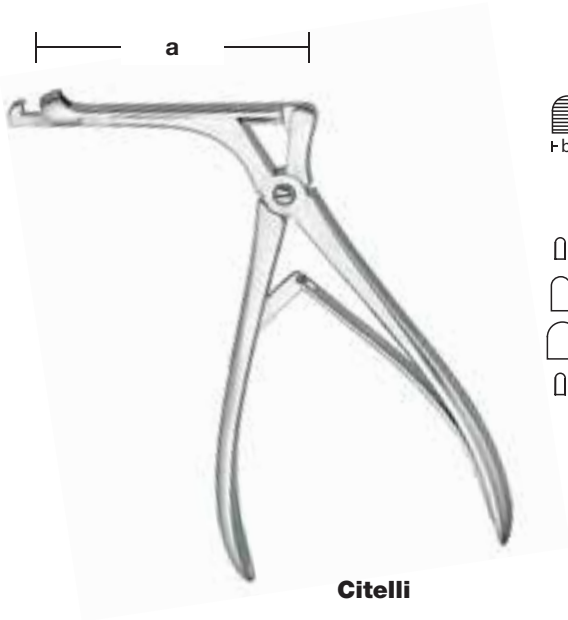

		a	b
	62.62.51	6 cm - 2 3/8"	1,5 mm
	62.62.52	6 cm - 2 3/8"	2,5 mm
	62.62.53	6 cm - 2 3/8"	4,0 mm
	62.62.54	17 cm - 6 3/4"	1,5 mm



TREVALLI

Ear Forceps
Pinzas auriculares
Pinces auriculaires
Pinze auricolari

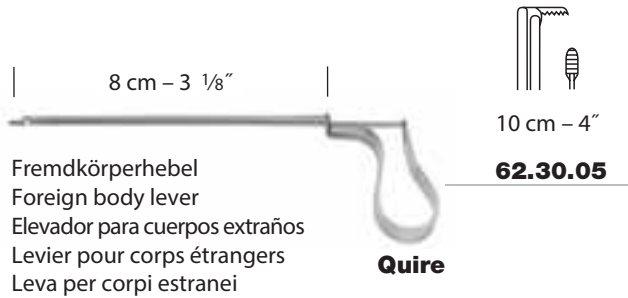

Fremdkörperhebel
Foreign body lever
Elevador para cuerpos extraños
Levier pour corps étrangers
Leva per corpi estranei

Quire

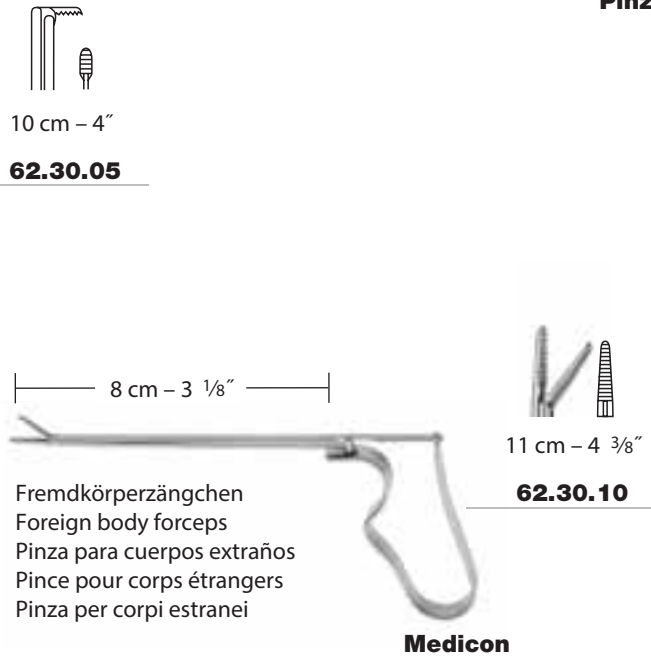

Fremdkörperzängchen
Foreign body forceps
Pinza para cuerpos extraños
Pince pour corps étrangers
Pinza per corpi estranei

Medicon

Ohrtamponzängchen
Ear dressing forceps
Pinzas auriculares para taponamiento
Pinces à pansements auriculaires
Pinze per tamponamento dell'orecchio

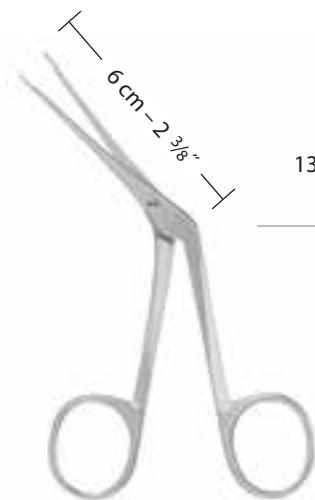

Hartmann



13,5 cm - 5 3/8"

62.30.20

feines Modell
delicate pattern
modelo fino
modèle délicat
modello delicato



13,5 cm - 5 3/8"

62.30.21

Standardmodell
Standard pattern
Modelo estándar
Modèle standard
Modello standard

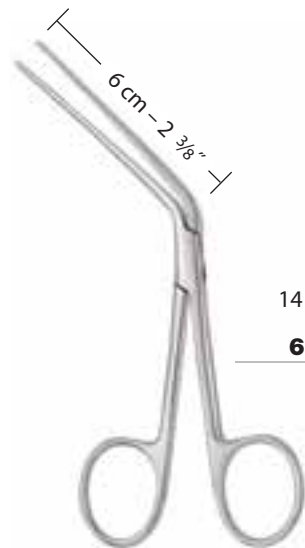

Tilley



14 cm - 5 1/2"

62.30.40



TREVALLi

Ohrzängchen
Ear Forceps
Pinzas auriculares
Pinces auriculaires
Pinze auricolari



Ohrzängchen mit daumenbeweglichen Ringgriffen,
(Katalognummer rot) ermöglichen ein exakteres Arbeiten.

Ear forceps with ring handles for thumb manipulation,
(catalogue number red) for a more precise work.

Pinza auriculares con anillos para manejar con el pulgar,
(número de catálogo rojo) permiten un trabajo más exacto.

Pinces auriculaires avec anneaux maniables par le pouce,
(numéro de catalogue rouge) permettent un travail plus exact.

Pinze auricolari con anelli di maneggio attraverso il pollice,
(numero de catalogo rosso) permette un lavoro più preciso.



Siehe Darstellungen auf den folgenden Seiten.
See illustrations on the following pages.
Véase las ilustraciones en las páginas siguientes.
Voyez les illustrations sur les pages suivantes.
Guardate le illustrazioni sulle seguenti pagine.



daumenbeweglich
thumb manipulation
manejar con el pulgar
maniable par le pouce
maneggio attraverso il pollice



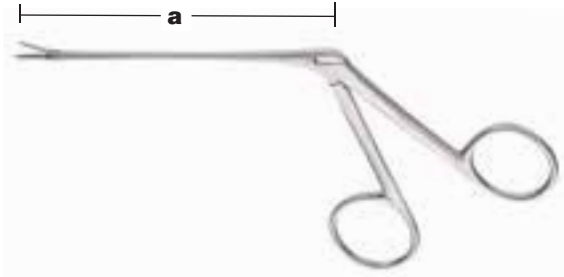

TREVALLi

Ohrzängchen
Ear Forceps
Pinzas auriculares
Pinces auriculaires
Pinze auricolari



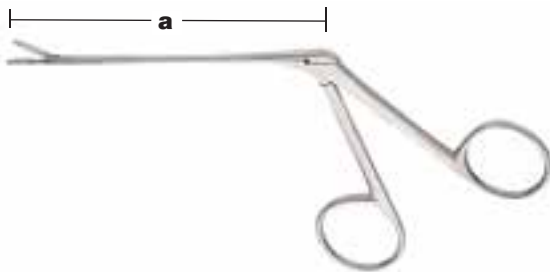

Hartmann

		a	
	62.31.10 ● 62.31.12	8 cm - 3 1/8"	
	62.31.20 ● 62.31.22	14 cm - 5 1/2"	
	62.31.30 ● 62.31.32	16 cm - 6 1/4"	



Hartmann

		a		
	62.32.50	8 cm - 3 1/8"		
	62.33.00 ● 62.33.01	8 cm - 3 1/8"		mittelfein medium-fine medio-fino semi-fine mediofine
	62.33.10 ● 62.33.12	8 cm - 3 1/8"		



daumenbeweglich
 thumb manipulation
 manejar con el pulgar
 maniable par le pouce
 maneggio attraverso il pollice

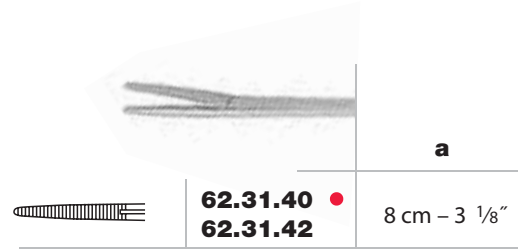
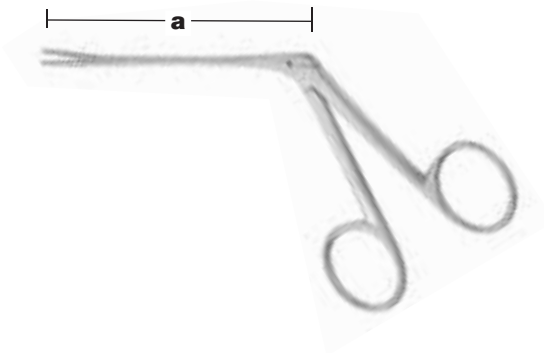

Hartmann-Noyes

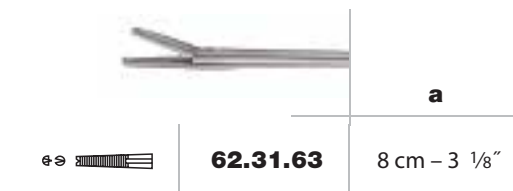

Hartmann

		a
Ø 2,0 mm	62.32.16 ● 62.32.11	8 cm - 3 1/8"
Ø 2,2 mm	62.32.17 ● 62.32.12	8 cm - 3 1/8"
Ø 2,5 mm	62.32.18 ● 62.32.13	8 cm - 3 1/8"
Ø 3,0 mm	62.32.19 ● 62.32.14	8 cm - 3 1/8"

Hartmann-Herzfeld

		a
Ø 2,0 mm	62.32.06 ● 62.32.01	8 cm - 3 1/8"
Ø 2,2 mm	62.32.07 ● 62.32.02	8 cm - 3 1/8"
Ø 2,5 mm	62.32.08 ● 62.32.03	8 cm - 3 1/8"
Ø 3,0 mm	62.32.09 ● 62.32.04	8 cm - 3 1/8"

Hartmann-Herzfeld

daumenbeweglich
 thumb manipulation
 manejar con el pulgar
 maniable par le pouce
 maneggio attraverso il pollice



TREVALLi

Ohrzängchen
Ear Forceps
Pinzas auriculares
Pinces auriculaires
Pinze auricolari

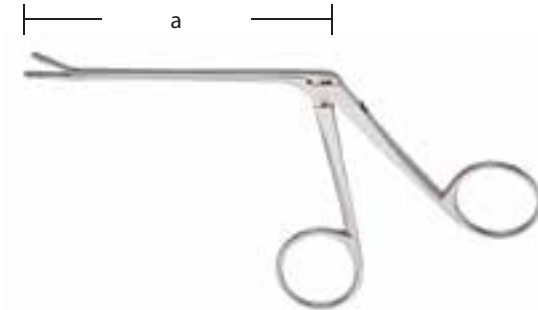

Entenschnabel
 Duckbill
 Pico de pato
 Bec de canard
 Becco d'anatra



Weingärtner

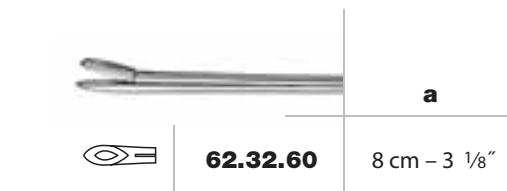

Strümpfel



Strümpfel-Baby

kräftiges Modell
 heavy pattern
 modelo fuerte
 modèle fort
 modello forte

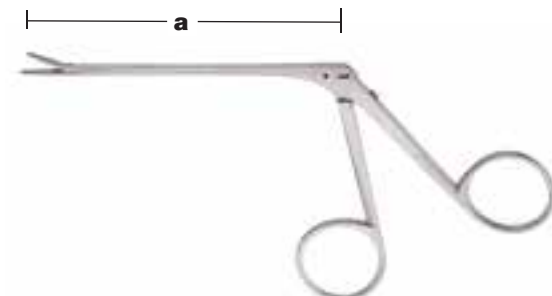

Bellucci



TREVALLi

Ohrzängchen
Ear Forceps
Pinzas auriculares
Pinces auriculaires
Pinze auricolari

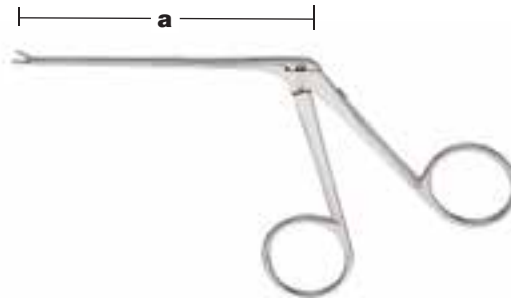

		a		
	4 x 0,5 mm	 3:1	62.34.31 ● 62.34.01	8 cm - 3 1/8"
	4 x 0,5 mm	 3:1	62.34.32 ● 62.34.12	8 cm - 3 1/8"
	3 x 0,5 mm	 3:1	62.34.34 ● 62.34.14	8 cm - 3 1/8"
	3 x 0,5 mm	 3:1	62.34.36 ● 62.34.16	8 cm - 3 1/8"
	3 x 0,5 mm	 3:1	62.34.37 ● 62.34.17	8 cm - 3 1/8"
	7 x 0,5 mm	 3:1	62.34.39 ● 62.34.22	8 cm - 3 1/8"

sehr fein
 delicate
 muy fina
 très fin
 molto fine

● daumenbeweglich
 thumb manipulation
 manejar con el pulgar
 maniable par le pouce
 maneggio attraverso il pollice



TREVALLi

Ohrzängchen
Ear Forceps
Pinzas auriculares
Pinces auriculaires
Pinze auricolari

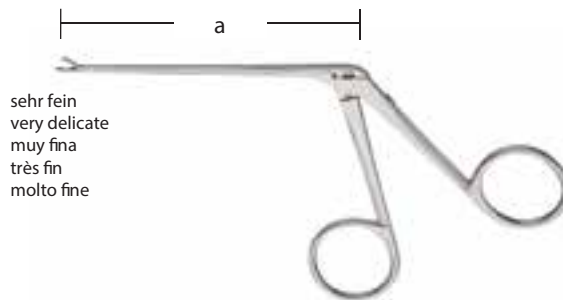

sehr fein
 very delicate
 muy fina
 très fin
 molto fine

			a	
	1 x 0,9 mm 	62.37.20 ● 62.37.12	8 cm – 3 1/8"	
	1 x 0,9 mm 	62.37.22 ● 62.37.14	8 cm – 3 1/8"	Löffelzängchen Forceps with cup jaws Pinzas con boca en forma de cucharilla Pinces mors curette Pinze con morsi a forma di cucchiaio
	1 x 0,9 mm 	62.37.24 ● 62.37.16	8 cm – 3 1/8"	
	1 x 0,9 mm 	62.37.26 ● 62.37.17	8 cm – 3 1/8"	

●
 daumenbeweglich
 thumb manipulation
 manejar con el pulgar
 maniable par le pouce
 maneggio attraverso il pollice



TREVALLi

Ohrzängchen
Ear Forceps
Pinzas auriculares
Pinces auriculaires
Pinze auricolari

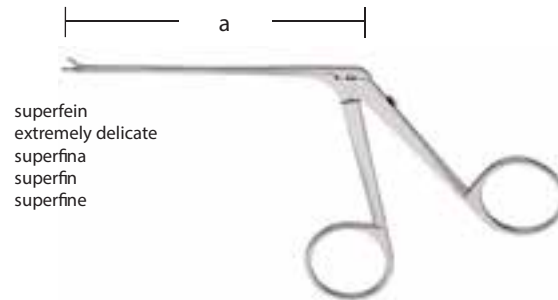

superfein
 extremely delicate
 superfina
 superfin
 superfine

		a		
	0,6 x 0,5 mm 	62.39.20 ● 62.39.12	8 cm - 3 1/8"	
	0,6 x 0,5 mm 	62.39.22 ● 62.39.14	8 cm - 3 1/8"	Löffelzängchen Forceps with cup jaws Pinzas con boca en forma de cucharilla Pinces mors curette Pinze con morsi a forma di cucchiaio
	0,6 x 0,5 mm 	62.39.24 ● 62.39.16	8 cm - 3 1/8"	
	0,6 x 0,5 mm 	62.39.26 ● 62.39.17	8 cm - 3 1/8"	
	4 x 0,4 mm 3:1 	62.35.16 ● 62.35.12	8 cm - 3 1/8"	
	4 x 0,4 mm 3:1 	62.35.18 ● 62.35.14	8 cm - 3 1/8"	



daumenbeweglich
 thumb manipulation
 manejar con el pulgar
 maniable par le pouce
 maneggio attraverso il pollice



TREVALLi

Ohrzangchen
Ear Forceps
Pinzas auriculares
Pinces auriculaires
Pinze auricolari

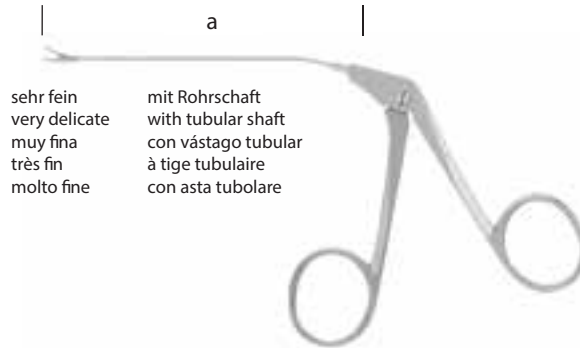

sehr fein
 very delicate
 muy fina
 tres fin
 molto fine

mit Rohrschaft
 with tubular shaft
 con vastago tubular
 a tige tubulaire
 con asta tubolare

	5 x 0,5 mm 3:1	62.50.12	8 cm – 3 1/8"	Wullstein
	4 x 0,5 mm 3:1	62.50.14	8 cm – 3 1/8"	Wullstein
	7 x 0,5 mm 3:1	62.50.23	8 cm – 3 1/8"	Wullstein
	∅ 0,9 mm 3:1	62.50.30	8 cm – 3 1/8"	Wullstein
	1,2 x 0,9 mm 3:1	62.50.35	8 cm – 3 1/8"	Wullstein Loffelzangchen Forceps with cup jaws Pinzas con boca en forma de cucharilla Pinces mors curette Pinze con morsi a forma di cucchiaio



5 x 2 mm

62.50.60

8 cm – 3 1/8"

Wullstein-Blakesley

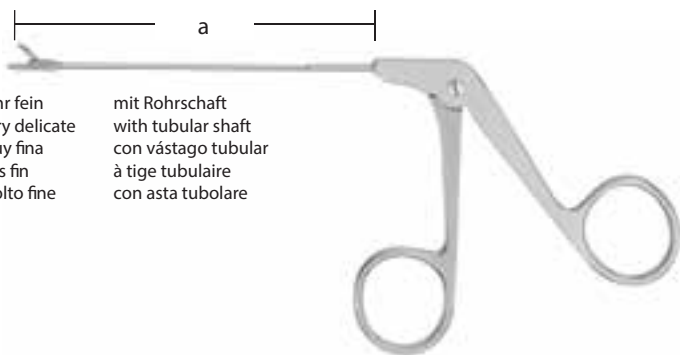

sehr fein
 very delicate
 muy fina
 tres fin
 molto fine

mit Rohrschaft
 with tubular shaft
 con vastago tubular
 a tige tubulaire
 con asta tubolare



TREVALLi

Ohrscherchen
Ear Scissors
Tijeras auriculares
Ciseaux auriculaires
Forbici auricolari

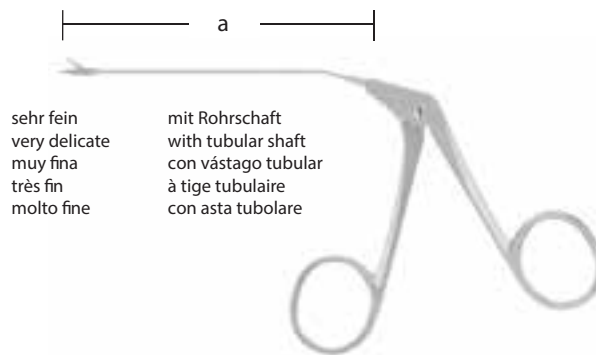

sehr fein
very delicate
muy fina
très fin
molto fine

mit Rohrschaft
with tubular shaft
con vástago tubular
à tige tubulaire
con asta tubolare

a

	62.50.52	gerade straight recta droites retta	8 cm – 3 1/8"		
	62.50.54	aufgewinkelt angled upwards angulado hacia arriba coudés en haut angolata verso l'alto	8 cm – 3 1/8"		
	62.50.56	rechts gebogen curved right curva derecho courbés à droite curva destra	8 cm – 3 1/8"		
	62.50.57	links gebogen curved left curva izquierdo courbés à gauche curva sinistra	8 cm – 3 1/8"		

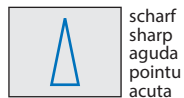

scharf
sharp
aguda
pointu
acuta



TREVALLi

Ohrscherchen
Ear Scissors
Tijeras auriculares
Ciseaux auriculaires
Forbici auricolari



Shea-Bellucci

	62.41.10	gerade straight recta droites retta		
	62.41.12	gerade straight recta droites retta		
	62.41.16	rechts gebogen curved right curva derecho courbés à droite curva destra		
	62.41.17	links gebogen curved left curva izquierdo courbés à gauche curva sinistra		

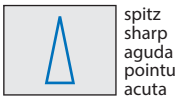

spitz
sharp
aguda
pointu
acuta



stumpf
blunt
roma
mousse
smussa



halbscharf
semi sharp
semi aguda
semi pointu
semi acuta



TREVALLi

Ohrscherchen
Ear Scissors
Tijeras auriculares
Ciseaux auriculaires
Forbici auricolari

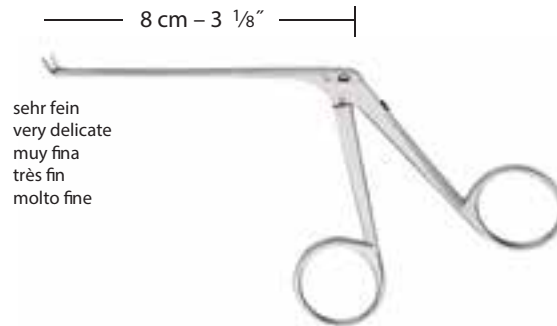

sehr fein
very delicate
muy fina
très fin
molto fine

Bellucci

	62.42.20 ●	gerade straight		
	62.42.11	recta droites retta		
	62.42.22 ●	gerade straight		
	62.42.12	recta droites retta		
	62.42.24 ●	aufgewinkelt angled upwards		
	62.42.13	angulado hacia arriba coudés en haut angolata verso l'alto		
	62.42.26 ●	rechts gebogen curved right		
	62.42.16	curva derecho courbés à droite curva destra		
	62.42.28 ●	links gebogen curved left		
	62.42.17	curva izquierdo courbés à gauche curva sinistra		



spitz
sharp
aguda
pointu
acuta



stumpf
blunt
roma
mousse
smussa



daumenbeweglich
thumb manipulation
manejar con el pulgar
maniable par le pouce
maneggio attraverso il pollice



TREVALLi

Stanzen, Drahtbiegezangchen
Punches, Wire Bending Forceps
Pinzas saca-bocadas, Pinzas para plegar alambre
Pinces emporte-pie, Pinces pour plier fil d'acier
Pinze taglianti, Pinze per piegare fili metallici

Hammerkopfstanzen
Malleus punches
Pinzas saca-bocadas para cabeza del martillo
Pinces emporte-pie pour la tete du marteau
Pinze taglianti per testa del martelletto

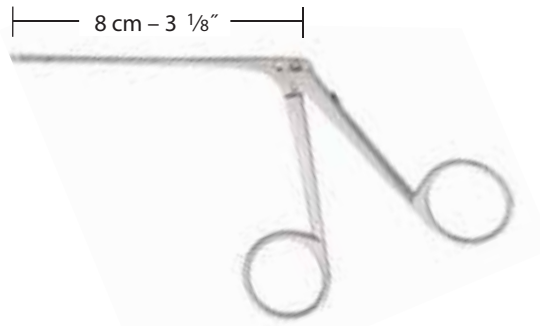
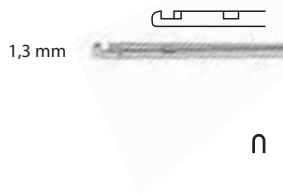

Dieter

∩	62.48.14	nach oben schneidend upwards cutting cortante hacia arriba coupant en haut tagliante verso l'alto	⤵	62.48.16	nach rechts schneidend right cutting cortante hacia derecho coupant  droite tagliante a destra
U	62.48.15	nach unten schneidend downwards cutting cortante hacia abajo coupant en bas tagliante verso in basso	⤴	62.48.17	nach links schneidend left cutting cortante hacia izquierdo coupant  gauche tagliante a sinistra



TREVALLi

Drahtbiegezangchen
Wire bending forceps
Pinzas para plegar alambre
Pincas pour plier fil d'acier
Pinze per piegare fili metallici

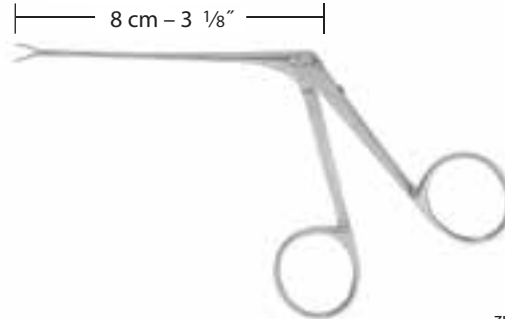

McGee

zum Einfuhren und Einsetzen
von Teflon-Draht-Stapesprothesen,
Maulteile leicht nach unten gebogen

for application of
stapedial Teflon-Wire prostheses,
jaws slightly curved downwards

para introducir e insertar
la protesis del estribo en hilo de teflon,
picos ligeramente curvos hacia abajo

pour l'introduction et la mise en place
de protheses stapediales en fil de teflon,
mors  courbure legere en bas

per l'introduzione e l'inserimento
di protesi di stapes in teflon,
morsi curvati leggermente in basso

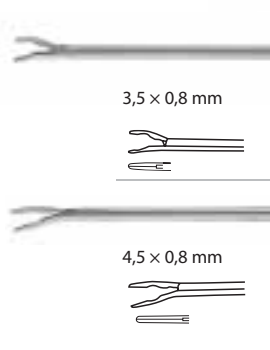

62.46.14

62.46.15



6 x 0,8 mm

62.46.11

7,5 cm - 3"

Schuknecht

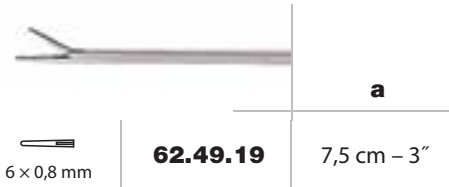

6 x 0,8 mm

62.49.19

7,5 cm - 3"

Fuller

Drahtbiegezangchen zum Schlieen der Drahtschlinge
von Teflon-Draht-Stapesprothesen nach dem Aufsetzen
auf Incus oder Malleus, Maulteile leicht nach unten gebogen.

Wire crimper for closing wire loop of stapedial
prostheses after attachment to incus or malleus.
Jaws slightly curved downwards.

Pinza plegadora para cerrar el lazo de hilo de teflon de la
protesis del estribo despues de haber sido colocada sobre
el yunque o el martillo, puntas ligeramente curvos hacia abajo.

Pince plieuse pour fermer l'anse en fil de teflon de protheses
stapediales apres leur placement autour de l'enclume ou du
marteau, mors  courbure legere en bas.

Pinza per chiudere le anse delle protesi in teflon dello stapes
dopo il loro innesto sul martelletto o sull'incudine, morsi curvati
leggermente in basso.

Fazangchen zum Halten und Einsetzen von
Teflon-Stapesprothesen

Forceps for holding and inserting stapedial
prostheses of teflon

Pinza prensora para coger y colocar
protesis de estribo en teflon

Pince  prehension pour fixation et insertion
de protheses stapediales en teflon

Pinza da presa per tenere e introdurre
protesi in teflon dello stapes



TREVALLi

Fasszängchen, Hammerkopfzange
Grasping Forceps, Malleus Forceps
Pinza para agarrar, Pinza para cabeza del martillo
Pince pour saisir, Pince pour la tête du marteau
Pinza per afferrare, Pinza per testa del martelletto

7 cm - 2 3/4"



Greven



3 x 1 mm

62.49.10

Fasszängchen zum Entfernen otosklerotischer Wucherungen, auch geeignet zum Einsetzen von Innerohr-Prothesen und Drainageknöpfen.

Grasping forceps for the removal of otosclerotic proliferations, also suitable for inserting prostheses into the inner ear and for setting drainage buttons.

Pinza prensora para remover proliferaciones otoscleróticas, también prestándose para la colocación de prótesis del oído y de botones de drenaje.

Pince à préhension pour l'enlèvement de végétations otoscléreuses, s'utilisant aussi pour l'insertion de prothèses dans l'oreille interne et de boutons de drainage.

Pinza da presa e per togliere escrescenze otosclerotiche, usabile anche per l'innesto di drenaggi e protesi nell'orecchio interno.



62.49.90

Schutzhülse aus Teflon, passend für alle Ohrzängchen bis Schaftlänge 80 mm. Schützt Schaft und Maulteile während Einzelsterilisation, autoklavierbar.

Protection tube of Teflon, suitable for all ear forceps up to 80 mm (3 1/8") length of shaft. Protects shaft and jaws during individual sterilization of the instrument, autoclavable.

Vaina protectora de teflón, apropiada para todas la pinzas auriculares hasta 80 mm de largo de vástago. Protege vástago y puntas durante su esterilización individual, autoclavable.

Gaine protectrice en téflon, s'adaptant à toutes les pinces auriculaires d'une longueur de tige allant jusqu'à 80 mm. Protège tige et mors pendant la stérilisation individuelle, autoclavable.

Tubo protettore in teflon, adatto per tutte le pinze auricolari con lunghezza dell'asta fino a 80 mm. Protegge asta e morsi durante la sterilizzazione singola, autoclavabile.



11,5 cm - 4 1/2"

62.48.10



Lempert

Hammerkopfzange
Malleus forceps
Pinza para cabeza del martillo
Pince pour tête du marteau
Pinza per testa del martelletto



TREVALLI

**Ohrküretten
Ear Curettes
Curetas auriculares
Curettes auriculaires
Curette auricolari**



Buck

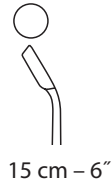

15 cm – 6"

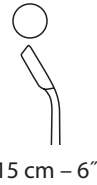

15 cm – 6"



62.12.09	# 00	Ø 1,5 mm	62.13.09	# 00	Ø 1,5 mm
62.12.10	# 0	Ø 1,9 mm	62.13.10	# 0	Ø 1,9 mm
62.12.11	# 1	Ø 2,5 mm	62.13.11	# 1	Ø 2,5 mm
62.12.12	# 2	Ø 2,7 mm	62.13.12	# 2	Ø 2,7 mm
62.12.13	# 3	Ø 3,4 mm	62.13.13	# 3	Ø 3,4 mm
62.12.14	# 4	Ø 4,0 mm	62.13.14	# 4	Ø 4,0 mm
62.12.15	# 5	Ø 4,5 mm	62.13.15	# 5	Ø 4,5 mm



Buck-Wullstein Micro



16 cm – 6 1/4"



62.13.50	# 0000	Ø 0,9 mm
62.13.51	# 000	Ø 1,1 mm
62.13.52	# 00	Ø 1,3 mm
62.13.53	# 0	Ø 1,8 mm
62.13.54	# 1	Ø 2,1 mm



Shapleigh

1



14 cm – 5 1/2"

62.14.31

2



14 cm – 5 1/2"

62.14.32



scharf
sharp
cortante
tranchant
tagliente



stumpf
blunt
romo
mousse
smussa

Ø = Innendurchmesser
Inside diameter
Diametro interior
Diamètre intérieur
Diametro interno



TREVALLI

Ohrküretten, Ohrschlingen
Ear Cures, Ear Loops
Curetas auriculares, Lazos auriculares
Curettes auriculaires, Anses auriculaires
Curette auricolari, Anse auricolari

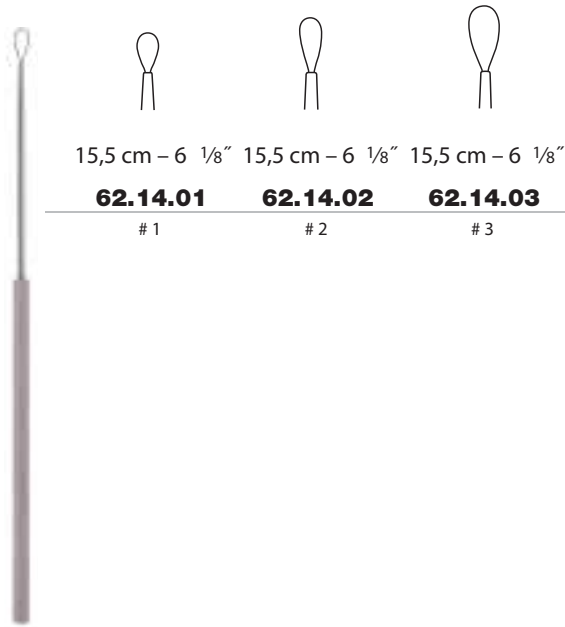

Billeau

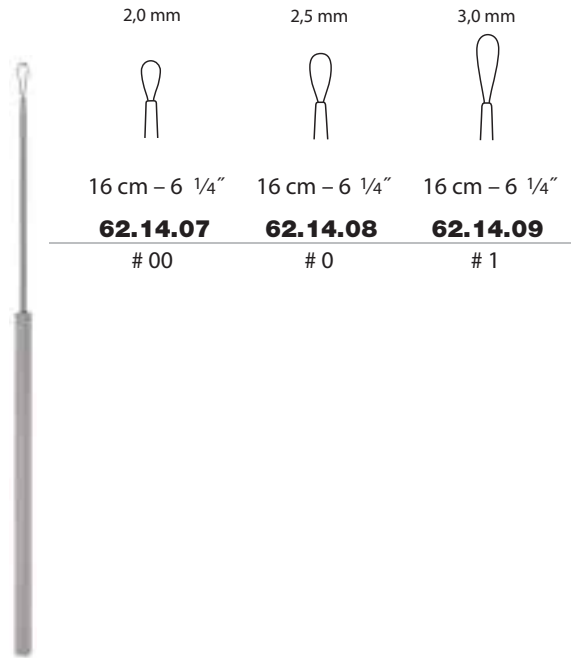

Billeau-Micro

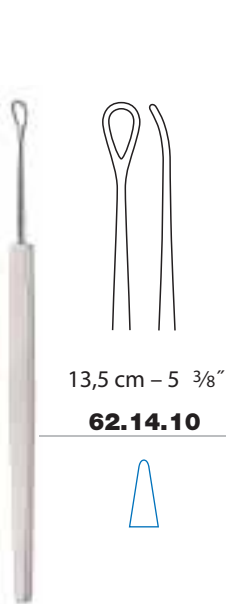

Langenbeck

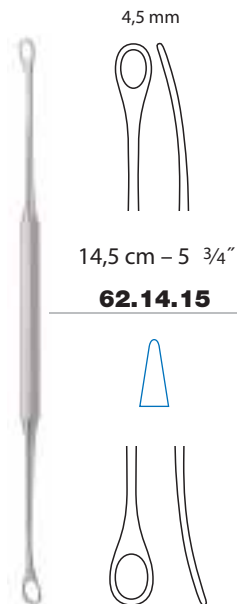

Coxeter

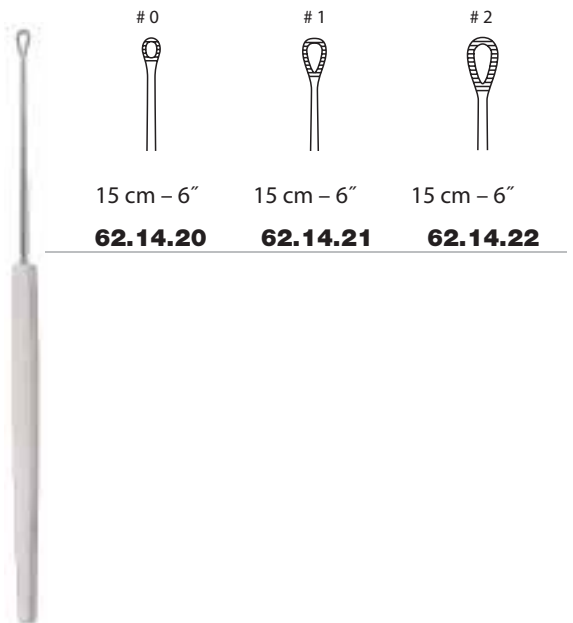

Weber-Loch





TREVALLi

Ohrhebel, Ohrsonden
Ear Levers, Ear Probes
Elevadores auriculares, Sondas auriculares
Leviers auriculaires, Sondes exploratrices auriculaires
Leve auricolari, Sonde esploratrici auricolari

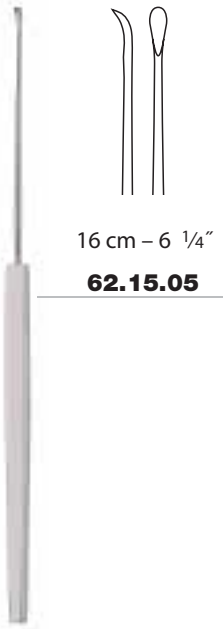

16 cm – 6 1/4"

62.15.05

Zaufal

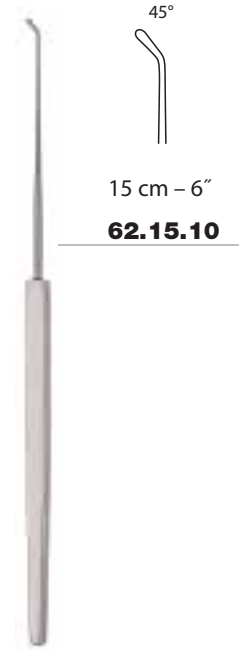

15 cm – 6"

62.15.10

Yankauer-Jansen

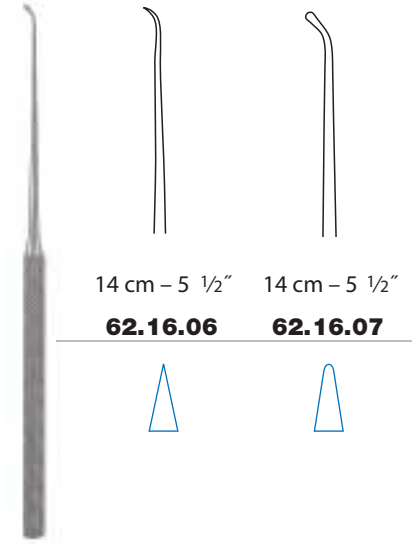

14 cm – 5 1/2"

62.16.06

14 cm – 5 1/2"

62.16.07



Wagener

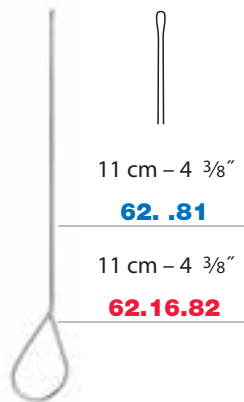

11 cm – 4 3/8"

62. .81

11 cm – 4 3/8"

62.16.82

Stacke

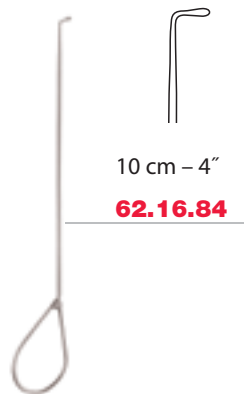

10 cm – 4"

62.16.84

Stacke-Frenzel



18,5 cm – 7 1/4"

58.30.20

Knopfsonde
Buttoned probe
Sonda abotonada
Sonde boutonnée
Sonda bottonuta

Jacobson

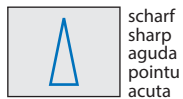

scharf
sharp
aguda
pointu
acuta



stumpf
blunt
roma
mousse
smussa

aus Neusilber
Nickel silver
de plata alemana
en maillechort
in argentone

aus Silber
Sterling silver
de plata pura
en argent pur
in argento puro



TREVALLi

**Ohrhäkchen
Ear Hooks
Ganchitos auriculares
Crochets auriculaires
Uncinetti auricolari**

Ohrhöffel und -Häkchen
Ear spoon and hook
Cucharilla y ganchito auricular
Cuiller et crochet auriculaire
Cucchiaio e uncinetto auricolare

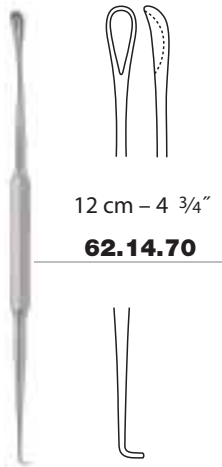

12 cm - 4 3/4"
62.14.70

Gross

Ohrkürette und -Häkchen
Ear curette and hook
Curetta y ganchito auricular
Curette et crochet auriculaire
Curetta e uncinetto auricolare

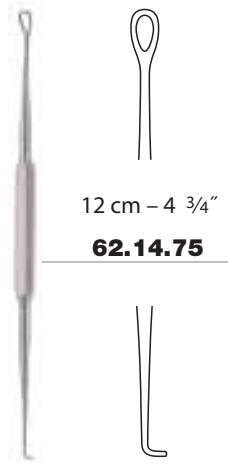

12 cm - 4 3/4"
62.14.75

Gross

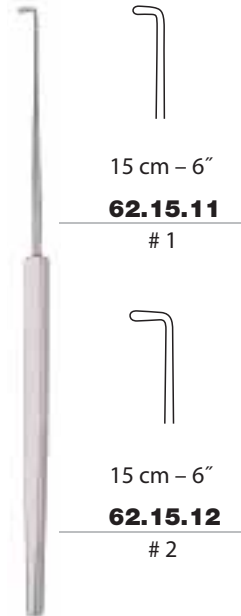

15 cm - 6"
62.15.11
1

15 cm - 6"
62.15.12
2

Jansen

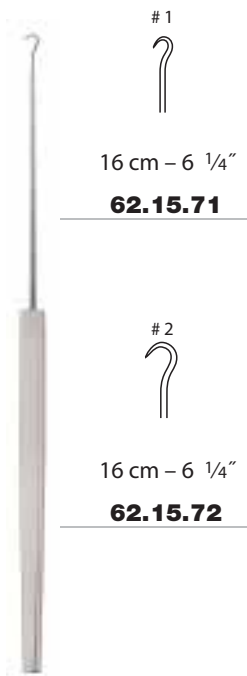

1
16 cm - 6 1/4"
62.15.71

2
16 cm - 6 1/4"
62.15.72

Hartmann

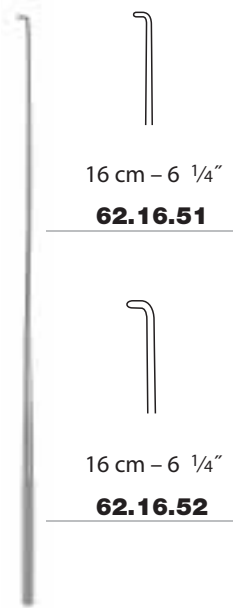

16 cm - 6 1/4"
62.16.51

16 cm - 6 1/4"
62.16.52

Day

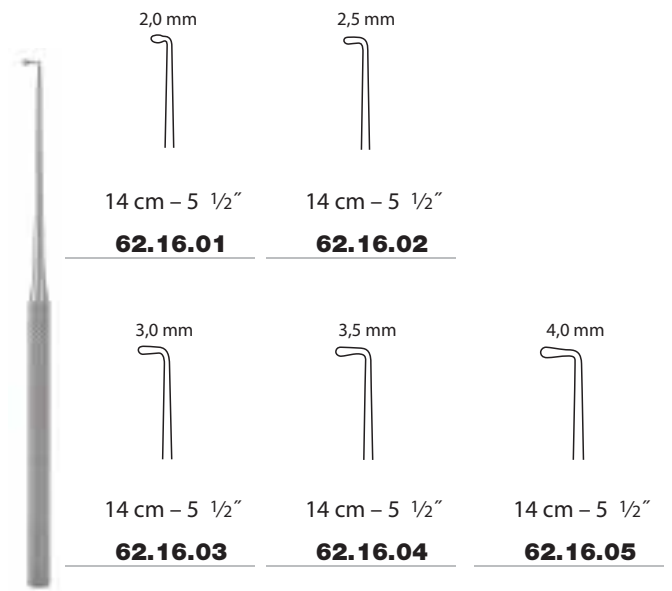

2,0 mm
14 cm - 5 1/2"
62.16.01

2,5 mm
14 cm - 5 1/2"
62.16.02

3,0 mm
14 cm - 5 1/2"
62.16.03

3,5 mm
14 cm - 5 1/2"
62.16.04

4,0 mm
14 cm - 5 1/2"
62.16.05

Wagner



TREVALLi

Trommelfellmesser, Sichelmesser
Tympanum Knives, Sickle Shaped Knives
Cuchillos para tímpano, Cuchillos falciformes
Couteaux pour le tympan, Bistouris auriculaires en forme de serpette
Bisturi per il timpano, Bisturi falciformi



18 cm - 7 1/8"

62.18.45

Sexton



18 cm - 7 1/8"

62.18.47



16 cm - 6 1/4"

62.17.60

Politzer



18 cm - 7 1/8"

62.18.53

Sexton



18 cm - 7 1/8"

62.18.57

Sexton





TREVALLi

**Parazentesenadeln
Tympanum Perforators
Agujas para paracentesis
Aiguilles à paracentèse
Aghi per paracentesi**

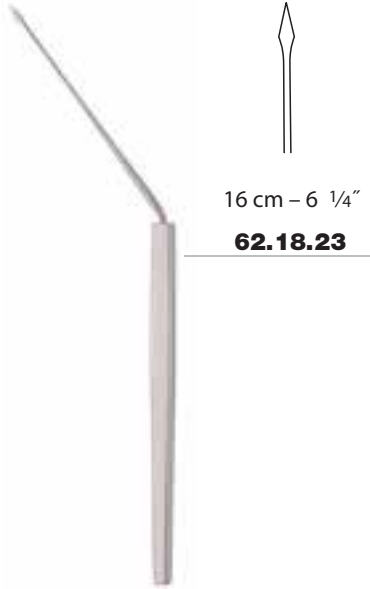

16 cm – 6 1/4"
62.18.23

Politzer (Royce)



18 cm – 7 1/8"
62.18.25

für Kinder
for children
para niños
pour enfants
per bambini

Lucae (Royce)

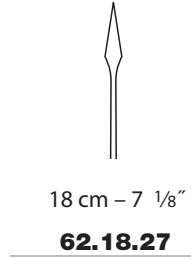

18 cm – 7 1/8"
62.18.27

für Erwachsene
for adults
para adultos
pour adultes
per adulti



19 cm – 7 1/2"
62.18.30

umsteckbar
reversible
reversible
réversible
giratorio

Politzer



15 cm – 6"
62.18.33

mit Schraubgriff
with screw-locking handle
con mango roscado
avec manche à visser
con manico a vite

Politzer



19 cm – 7 1/2"
62.18.35

Lucae



TREVALLi

Exostosemeißel, Ohrkatheter
Chisels for Exostosis, Ear Catheters
Cinceles para exostosis, Sondas auriculares
Ciseaux burins à exostose, Sondes auriculaires
Scalpelli per esostosi, Sonde auricolari

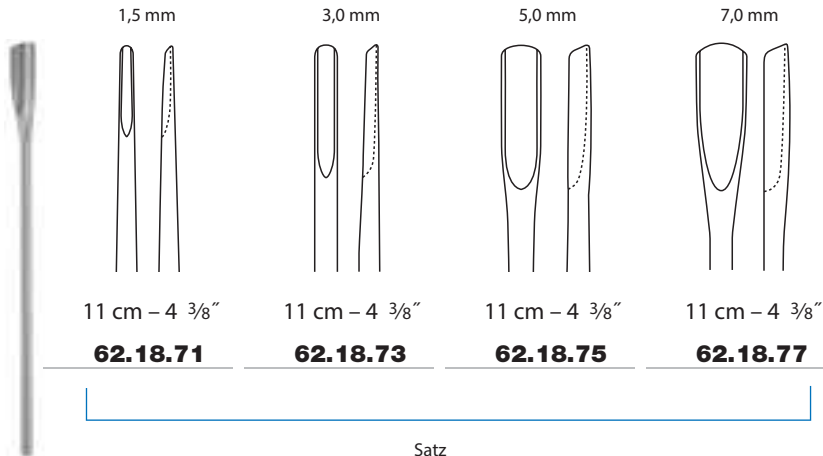

62.18.70 Satz
Set
Juego
Jeu
Serie

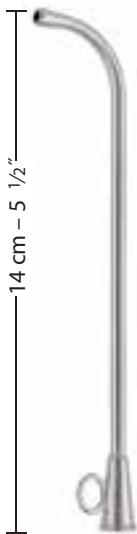

Hartmann

● 62.20.11	# 1	Ø 2,5 mm	● 62.20.14	# 4	Ø 4 mm
● 62.20.12	# 2	Ø 3 mm	● 62.20.15	# 5	Ø 5 mm
● 62.20.13	# 3	Ø 3,5 mm			



62.20.30

Schlaucholive für HARTMANN Ohrkatheter
Olive-shaped tube connector for HARTMANN ear catheters
Oliva para empalme de tubo para sondas auriculares según HARTMANN
Olive (Raccord-tuyau) pour sondes auriculaires de HARTMANN
Raccordo ad oliva per sonde auricolari di HARTMANN



TREVALLI

Nadeln
Needles
Agujas
Aiguilles
Aghi



15 cm - 6"

63.06.01

Barbara



15 cm - 6"

63.06.02

Barbara

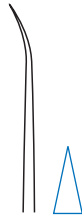

15 cm - 6"

63.06.03

Barbara

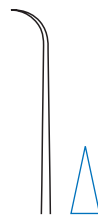

15 cm - 6"

63.06.04

Rosen

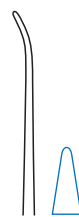

15 cm - 6"

63.06.05

Barbara

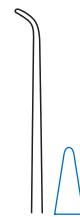

15 cm - 6"

63.06.06

Barbara

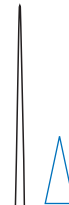

15 cm - 6"

63.07.01

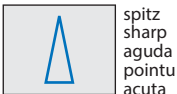

spitz
sharp
aguda
pointu
acuta



stumpf
blunt
roma
mousse
smussa



TREVALLi

Häkchen
Hooks
Ganchitos
Crochets
Uncini

	25°		45°	
0,3 mm	63.06.13	0,3 mm	63.06.33	
0,6 mm	63.06.16	0,6 mm	63.06.36	
1,0 mm	63.06.20 Shambaugh	1,0 mm	63.06.40 Shambaugh	
	90°	45°	45°	45°
1,5 mm	63.06.07	1,5 mm	63.06.41	2,0 mm
	Austin			63.06.45
		2,5 mm		3,0 mm
		63.06.43		63.06.49
			Shea	Austin
			Sondierhaken	Attikus-Dissektor
			Oblique pick	Attic dissector
			Ganchito explorador	Disector para el ático
			Crochet à exploration	Dissecteur pour l'attique
			Uncino per esplorazione	Dissettore per l'attico





TREVALLI

Häkchen
Hooks
Ganchitos
Crochets
Uncini



90°



0,3 mm	63.06.53
0,6 mm	63.06.56
0,8 mm	63.06.58
1,0 mm	63.06.60 Shambaugh
1,2 mm	63.06.62
1,5 mm	63.06.65

90°



2,0 mm	63.06.70
2,5 mm	63.06.74
3,0 mm	63.06.76
4,0 mm	63.06.78
5,0 mm	63.06.79



0,5 mm	63.06.75
1,0 mm	63.06.80



63.06.85

Goldmann

Häkchen zum Festhalten des Malleus
Retractor for malleus
Ganchito para sujetar el martillo
Crochet pour retenir le marteau
Uncino per sostenere il martello



63.06.90

Plester

Zum Anrauen der Trommelfellrückseite
For roughening the back of the tympanic membrane
Para cardar la parte posterior de la membrana del tímpano
Pour égratigner la partie postérieure du tympan
Per arruvidire la parte posteriore della membrana del timpano



63.06.95

Rosen

Fenestrierhaken für ovales Fenster
Fenestrator for oval windows
Ganchito para la fenestración para la ventana ovalado
Crochet à fenestration pour la fenêtre ovale
Uncino fenestrato per finestra ovale

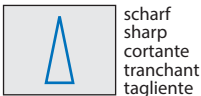



TREVALLi

**Häkchen
Hooks
Ganchitos
Crochets
Uncini**

zum Anheben des Incus
for lifting the incus
para levantar el yunque
pour soulever l'enclume
per sollevare l'incudine



	90°		
63.07.72	0,6 mm	Antoli-Candela	
63.07.92	1,0 mm		
nach rechts abgewinkelt right angled acodada a la derecha coudé à droite angolato a destra			

	90°		
63.07.73	0,6 mm	Antoli-Candela	
63.07.93	1,0 mm		
nach links abgewinkelt left angled acodada a la izquierda coudé à gauche angolato a sinistra			

Fußplattenhäkchen
Footplate hooks
Ganchitos para la platina estapediense
Crochets pour la platine de l'étrier
Uncini per la platina dello stapes



McGee

63.07.75	0,5 mm	63.07.85	0,5 mm
63.07.80	1,0 mm	63.07.90	1,0 mm
nach oben gebogen curved upwards curva hacia arriba courbé en haut curvo verso l'alto		nach unten gebogen curved downwards curva hacia abajo courbé en bas curvo verso il basso	



	0,2 mm	63.08.02	Fisch
	0,6 mm	63.08.06	Plester



TREVALLi

Instrumente nach Zöllner
Instruments acc. to Zöllner
Instrumentos según Zöllner
Instrumentes selon Zöllner
Strumenti secondo Zöllner



Nadel
Needle
Aguja
Aiguille
Ago

63.17.01



63.17.24



63.17.25

Fussplattenhäkchen
Footplate hooks
Ganchitos para la platina estapediense
Crochets pour la platine de l'étrier
Uncini per la platina dello stapes

45°



0,5 mm

63.17.05

45°



0,5 mm

63.17.06

60°



1,0 mm

63.17.10

60°



1,0 mm

63.17.11

90°



0,5 mm

63.17.15

Häkchen
Hooks
Ganchitos
Crochets
Uncini

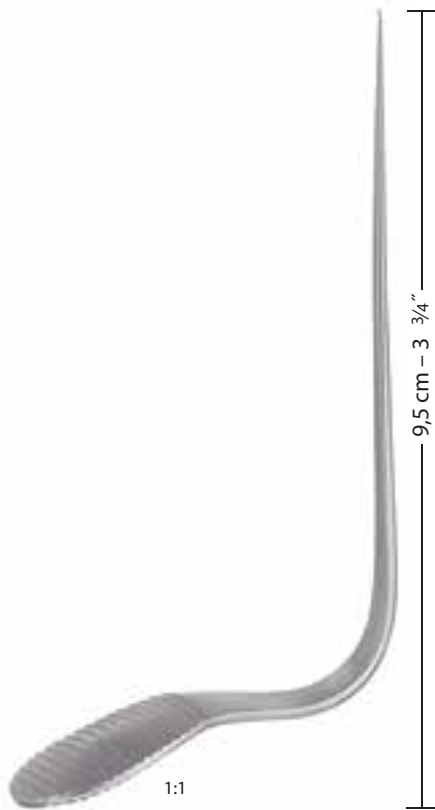

1:1

Zöllner

90°



0,5 mm

63.17.16

90°



2,5 mm

63.17.18

90°



1,0 mm

63.17.20

90°



1,0 mm

63.17.21

Häkchen
Hooks
Ganchitos
Crochets
Uncini



TREVALLi

Instrumente nach Zöllner
Instruments acc. to Zöllner
Instrumentos según Zöllner
Instrumentes selon Zöllner
Strumenti secondo Zöllner

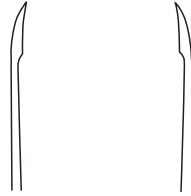

Sichelmesser
Sickle knives
Cuchillos en forma de hoz
Couteaux en forme de serpette
Coltelli falciforme

63.17.35

63.17.36

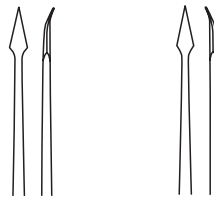

Lanzetten
Lancets
Lancetas
Couteaux lanceol
Lancette

63.17.43

63.17.44

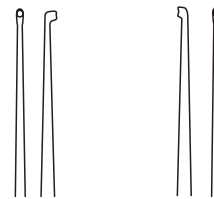

Küretten
Curettes
Curetas
Curettes
Curette

0,8 mm

0,8 mm

63.17.51

63.17.52

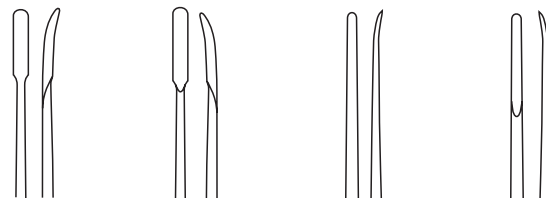

Raspatorien
Raspatories
Legras
Rugines
Periostotomi

2,0 mm

2,0 mm

1,2 mm

1,2 mm

63.17.61

63.17.62

63.17.64

63.17.65

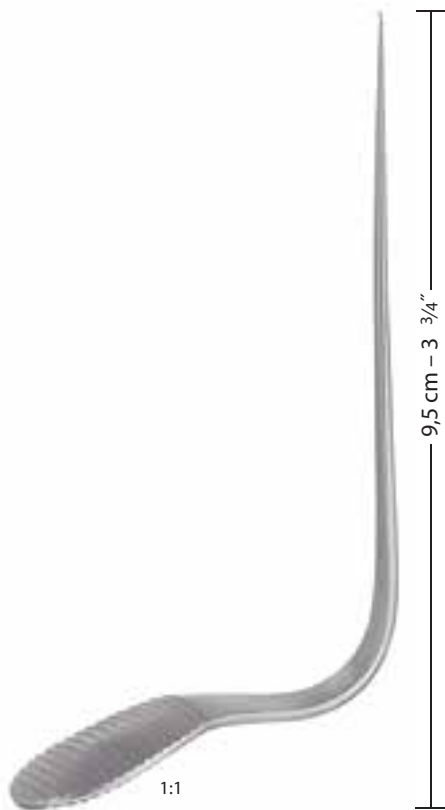

1:1

Zöllner



TREVALLi

Messer für die Otologie
Knives for Otology
Cuchillos para otología
Couteaux pour otologie
Coltelli per otologia



45°



Inzisionsmesser
 Incision knives
 Cuchillos para incisiones
 Couteaux à incision
 Coltelli per incisione

90°



Rundschnittmesser
 Circular cutting knives
 Cuchillos redondos
 Couteaux à forme ronde
 Coltelli a taglio rotondo

Ø 1,0 mm	63.08.10
Ø 1,5 mm	63.08.15
Ø 2,0 mm	63.08.20
Ø 2,3 mm	63.08.23
Ø 2,5 mm	63.08.25
Ø 3,0 mm	63.08.28
Ø 3,5 mm	63.08.29

Ø 1,0 mm	63.08.30
Ø 1,5 mm	63.08.35
Ø 2,0 mm	63.08.40
Ø 2,3 mm	63.08.43
Ø 2,5 mm	63.08.45

Antoli-Candela

30°



Ø 1,0 mm
63.09.01

House

Rundmesser zum Lösen
 der Incus-Stapes-Verbindung

Round knife for separation
 of Incudo-Stapedial joint

Cuchillo redondo para separar
 la conexión entre el yunque y el estribo

Couteau rond pour séparer
 la connexion entre l'enclume et l'étrier

Coltello rotondo per la separazione
 della connessione tra Incus-Stapes

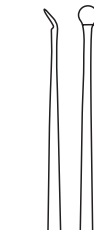

Ø 2,5 mm
63.09.02

House

45°



Ø 3,0 mm
63.09.03

Goldmann

Inzisionsmesser und Raspatorium
 für die Gehörgangswand

Knife and raspatory
 for auditory meatus wall

Cuchillo para incisiones y legra
 para la pared del conducto auditivo

Couteau à incision et rugine
 pour la paroi du conduit auditif

Coltello d'incisione e periostotomo
 per il condotto uditivo



TREVALLi

Messer für die Otologie
Knives for Otology
Cuchillos para otología
Couteaux pour otologie
Coltelli per otologia



45°

Ø 1,5 mm

63.09.06

Rosen

Separiermesser
Knife-Curette
Cuchillo separador
Couteau-séparateur
Coltello di separazione

15 cm - 6"



45°

Ø 1,0 mm

63.09.11

Antoli-Candela

Rundmesser zum Lösen
der Incus-Stapes-Verbindung
Round knife for separation
of Incudo-Stapedial joint
Cuchillo redondo para separar
la conexión entre el yunque y el estribo
Couteau rond pour séparer
la connexion entre l'enclume et l'étrier
Coltello rotondo per la separazione
della connessione tra Incus-Stapes

15 cm - 6"



90°

Ø 2,0 mm

63.09.22

Austin

Rundmesser für Inzisionen
im äußeren Gehörgang
Round knives for incision
of external auditory canal
Cuchillos redondos para incisiones
en el conducto auditivo externo
Couteaux ronds pour incisions
dans le conduit auditif externe
Coltelli rotondi per incisione
nel condotto uditivo esterno

15 cm - 6"



90°

Ø 3,0 mm

63.09.25

Gerlach



45°

63.09.53

Rosen

Inzisionsmesser
Incision knife
Cuchillo para incisiones
Couteau à incision
Coltello per incisione



TREVALLi

Messer für die Otologie
Knives for Otology
Cuchillos para otología
Couteaux pour otologie
Coltelli per otologia

2,5 x 1,5 mm

3,5 x 2,0 mm



15 cm - 6"

15 cm - 6"

63.10.03

63.10.05

Guilford-Wright Plester

Lappenmesser
Flap knives
Cuchillos para lóbulos
Couteaux à lambeaux
Coltelli per lobulo

3,0 x 1,0 mm



15 cm - 6"

63.10.32

Austin

Sichelmesser
Sickle knife
Cuchillo en forma de hoz
Couteau en forme de serpette
Coltello falciforme



15 cm - 6"

63.10.35

Diszisionsmesser für die Fußplatte
Discission knife for the footplate
Cuchillo de discision para la platina estapediense
Couteau à discision pour la platine de l'étrier
Coltello da discissione per la platina dello stapes



19 cm - 7 1/2"

19 cm - 7 1/2"

66.52.80

66.52.81

Sichelmesser
Sickle knives
Cuchillos en forma de hoz
Couteaux en forme de serpette
Coltelli falciforme



TREVALLi

Messer für die Otologie
Knives for Otology
Cuchillos para otología
Couteaux pour otologie
Coltelli per otologia



18,5 cm – 7 1/4"
58.33.01

Sichelmesser
Sickle knife
Cuchillo en forma de hoz
Couteau en forme de serpette
Coltello falciforme

Koons

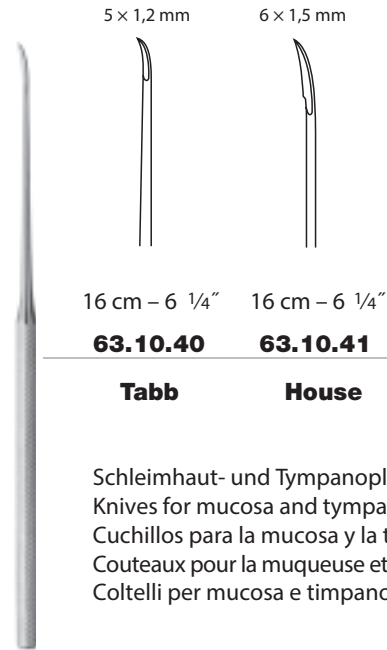

5 x 1,2 mm 6 x 1,5 mm
16 cm – 6 1/4" 16 cm – 6 1/4"
63.10.40 **63.10.41**

Tabb **House**

Schleimhaut- und Tympanoplastikmesser
Knives for mucosa and tympanoplasty
Cuchillos para la mucosa y la timpanoplastía
Couteaux pour la muqueuse et la tympanoplastie
Coltelli per mucosa e timpanoplastica

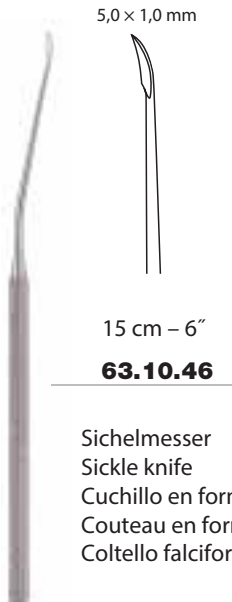

5,0 x 1,0 mm
15 cm – 6"
63.10.46

Sichelmesser
Sickle knife
Cuchillo en forma de hoz
Couteau en forme de serpette
Coltello falciforme

Schuknecht



75 x 25 x 7 mm
63.10.99

Schleifstein
Grinding stone
Piedra afiladora
Pierre à affûter
Pietra per affilare

Arkansas



TREVALLI

Raspatorien
Raspatories
Legras
Rugines
Periostotomi

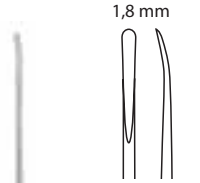

15 cm - 6"

63.11.02

Raspatorium zum Ablösen
von weichem Gewebe

Raspatory for dissection
of soft tissue

Legra para liberar
tejidos blandos

Rugine pour décoller
des tissus mous

Periostotomo per staccare
tessuto morbido

Antoli-Candela

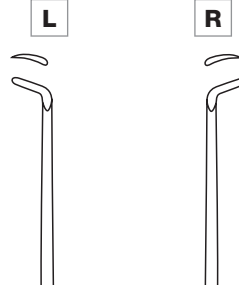

15 cm - 6"

63.11.51

15 cm - 6"

63.11.50

Raspatorien für das ovale Fenster, kräftig
Raspatories for oval window, heavy pattern
Legras para la ventana oval, modelo fuerte
Rugines pour la fenêtre ovale, modèle robuste
Periostotomi per la finestra ovale, modello robusto

Hough

15 x 1,5 mm

15 x 1,0 mm

15 x 1,2 mm



15 cm - 6"

63.11.15

15 cm - 6"

63.11.21

15 cm - 6"

63.11.22

Rosen



links
left
izquierdo
gauche
sinistro



rechts
right
derecho
droite
destro

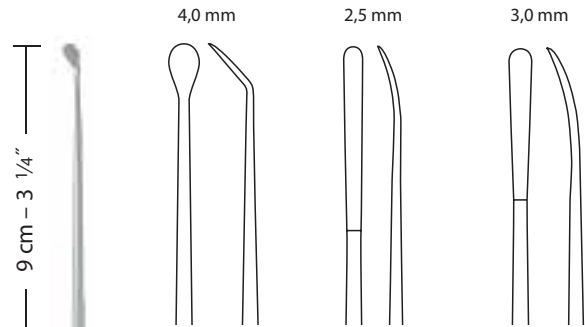

9 cm - 3 1/4"

18,5 cm - 7 1/4"

58.30.16

18,5 cm - 7 1/4"

58.30.17

18,5 cm - 7 1/4"

58.30.18

Yasargil



TREVALLI

Raspatorien
Raspatories
Legras
Rugines
Periostotomi

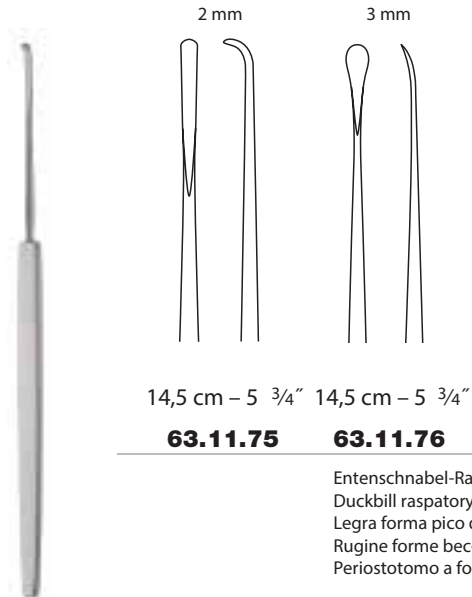

Shambaugh-Derlacki



TREVALLi

**Elevatorien, Dissektor
Elevators, Dissector
Elevadores, Disector
Elévateurs, Dissecteur
Elevatori, Dissettore**



2,5 mm



15 cm – 6"

63.11.03

Elevatorium und Dissektions-
messer für weiches Gewebe

Elevator and dissector knife
for soft tissues

Elevador y disecador
para tejidos blandos

Elévateur et dissecteur
pour les tissus mous

Elevatore e dissettore
per tessuto morbido

Goldmann



1 mm



15 cm – 6"

63.11.11

Stapes-Elevatorium
Stapes elevator
Elevador estapediense
Elévateur stapédien
Elevatore per lo stapes

House



1 mm



23 cm – 9"

58.32.21

Dissektor
Dissector
Disector
Dissecteur
Dissettore



TREVALLi

Exkavatore, Flachmeißel, Scharfe Löffel
Excavators, Chisel, Sharp Curettes
Excavadores, Cincel, Cucharillas cortantes
Excavateurs, Ciseau-burin, Curettes tranchantes
Escavatori, Scalpello, Cucciai taglienti

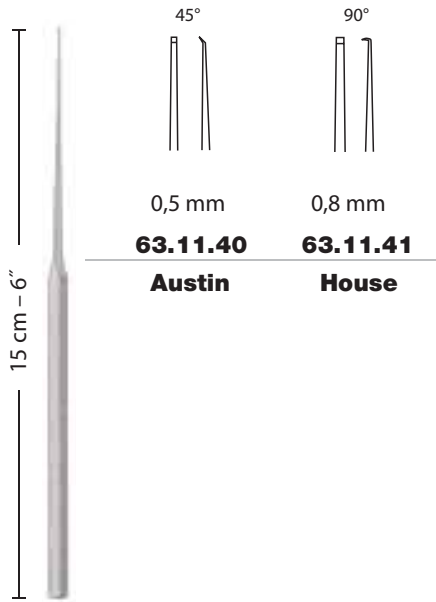

45° 90°
0,5 mm 0,8 mm
63.11.40 **63.11.41**
Austin **House**

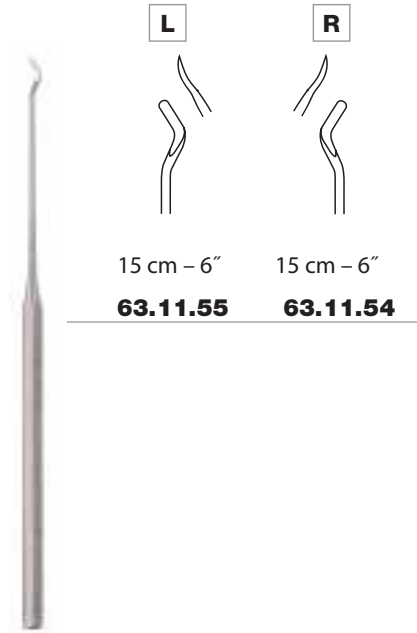

L **R**
15 cm - 6" 15 cm - 6"
63.11.55 **63.11.54**

Austin

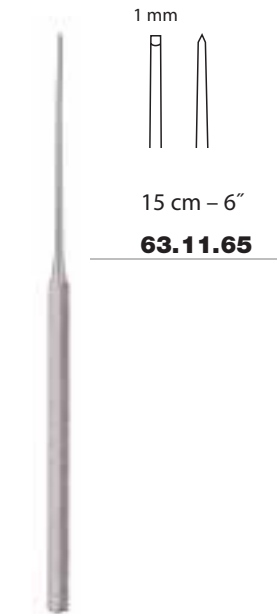

1 mm
15 cm - 6"
63.11.65

Austin

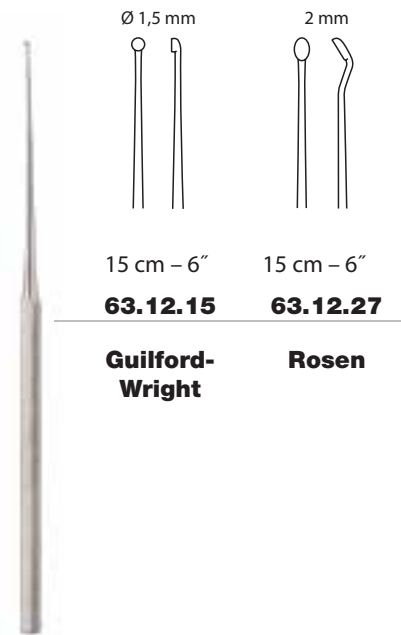

Ø 1,5 mm 2 mm
15 cm - 6" 15 cm - 6"
63.12.15 **63.12.27**

Guilford-Wright **Rosen**

L links
left
izquierdo
gauche
sinistro

R rechts
right
derecho
droite
destro



TREVALLi

**Tiefensonden, Einführungsgabel
Depth Gauges, Wire Guide
Sondas de profundidad, Horquilla para introducir
Sondes de profondeur, Forchette
Sonda di profondità, Forchetta per introduzione**



17 cm – 6 3/4"

63.14.10

Hough

Tiefensonde mit Markierungen bei:
Depth gauge, marks at:
Sonda de profundidad, graduada a:
Sonde de profondeur, marquées à:
Sonda di profondità con marcature a:

3,5- 4,0-4,5 mm



63.14.12

Fisch Winter

Tiefensonde, biegsam, mit Markierungen bei:
Depth gauge, flexible, marks at:
Sonda de profundidad, doblable, graduada a:
Sonde de profondeur, flexible, marquées à:
Sonda di profondità, piegabile, con marcature a:

3,0- 4,0- 5,0- 6,0 mm

mit Schutzkappe
with protective cap
con caperuza protectora
avec capuchon protecteur
con guaina



Ø

4 mm	63.14.04
6 mm	63.14.06

Prüfzylinder
Testing cylinder
Cilindro verificación
Cylindre de vérification
Cilindro di prova

Fisch



15 cm – 6"

63.14.33

Einführungsgabel für Stapes-Prothesen
Wire guide and applicator for stapedial prostheses
Horquilla para introducir prótesis estapedienses
Fourchette pour introduire des prothèses de l'étrier
Forchetta per introdurre protesi di stapes



TREVALLI

Scharfe Löffel
Sharp Curettes
Cucharillas cortantes
Curettes tranchantes
Cucchiai taglienti



1:1

House

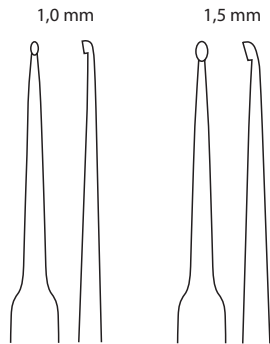

15 cm - 6"

63.12.70

15 cm - 6"

63.12.75

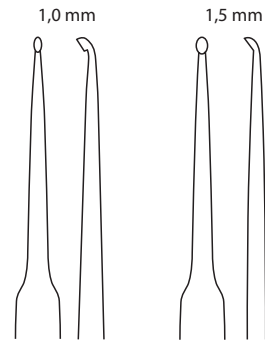

15 cm - 6"

63.12.80

15 cm - 6"

63.12.85

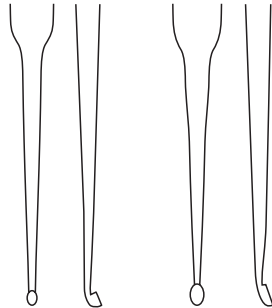

1,2 mm

1,8 mm

Scharfe Doppellöffel für die Stapedektomie,
Arbeitsteil leicht nach vorne abgewinkelt

Double-ended sharp curettes for stapedectomy,
cups slightly angled forward

Cucharillas doble para la estapedectomia, partes
de trabajo ligeramente acodadas hacia delante

Curettes doubles pour la stapédectomie,
parties opérantes légèrement coudées en avant

Cucchiai doppi taglienti per la stapdectomia,
parte lavorativa leggermente angolata in avanti

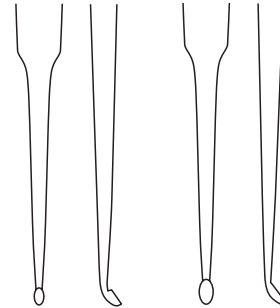

1,2 mm

1,8 mm

Scharfe Doppellöffel für die Stapedektomie,
Arbeitsteil stark nach vorne abgewinkelt

Double-ended sharp curettes for stapedectomy,
cups strongly angled forward

Cucharillas doble para la estapedectomia, partes
de trabajo fuertemente acodadas hacia delante

Curettes doubles pour la stapédectomie,
parties opérantes fortement coudées en avant

Cuchiai doppio tagliente per la stapedectomia,
parte lavorativa fortemente angolata in avanti



TREVALLi

**Perforatoren, Penetrator, Trepine
Perforators, Penetrator, Trepine
Perforadores, Broca, Trépano
Perforateurs, Foret, Tréphine
Perforatori, Penetratore, Trefina**

Ø 1 mm



15 cm – 6"

63.65.90

Hand-Perforationsbohrer
Trokarspitze
Hand perforator
Trocar point
Perforador de mano
Punta de trocar
Perforateur à main
Pointe trocart
Perforatore a mano
Punta a trocar

Larkin

Ø 0,8 mm



15 cm – 6"

63.65.92

Hand-Penetrator
Hand penetrator
Broca de mano
Foret à main
Penetratore a mano

Larkin

Ø 0,8 mm



15 cm – 6"

63.65.94

Hand-Trepine
Hand trephine
Trefina de mano
Tréphine à main
Trefina a mano

Larkin



15 cm – 6"

Ø	
0,3 mm	63.65.73
0,4 mm	63.65.74
0,5 mm	63.65.75
0,6 mm	63.65.76
0,7 mm	63.65.77
0,8 mm	63.65.78

Fisch

Perforatoren
Perforators
Perforadores
Perforateurs
Perforatori



TREVALLI

ENT INSTRUMENTS

Rhinologie
Rhinology
Rinología
Rhinologie
Rinologia

trevalli@mweb.co.za



TREVALLi

**Nasenspekula
Nasal Specula
Espéculos nasales
Spéculums nasaux
Specoli nasali**

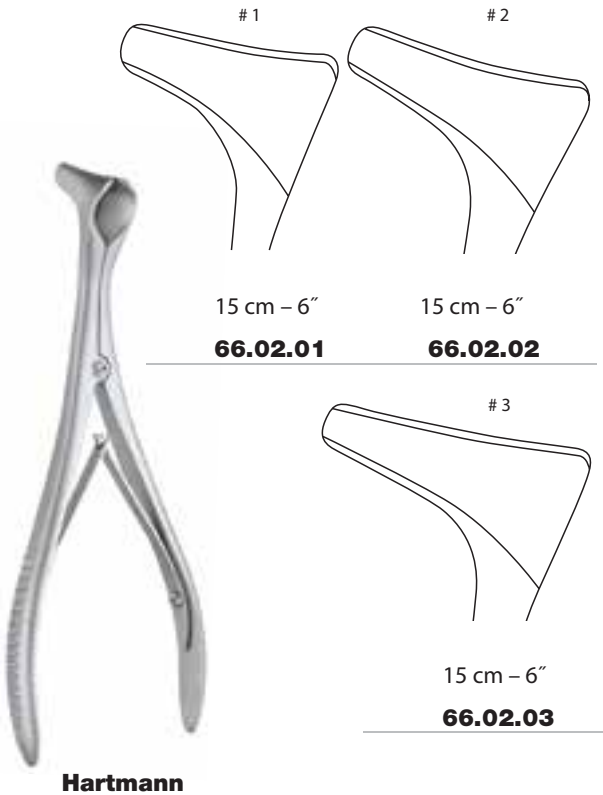

Spekulum zur Entfernung von Osteosynthesematerialien
Speculum for removal of osteosynthesis materials
Espéculo para la remoción de implantes para la osteosíntesis
Spéculum pour l'enlèvement de matériel d'ostéosynthèse
Specolo per rimozione di mezzi di sintesi

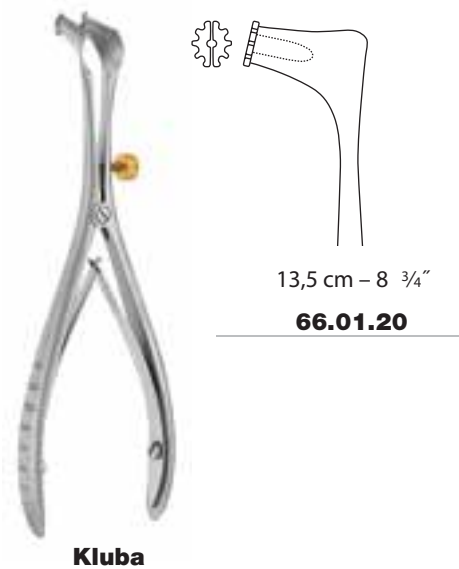



TREVALLi

**Nasenspekula
Nasal Specula
Espéculos nasales
Spéculums nasaux
Specoli nasali**



Hartmann-Halle

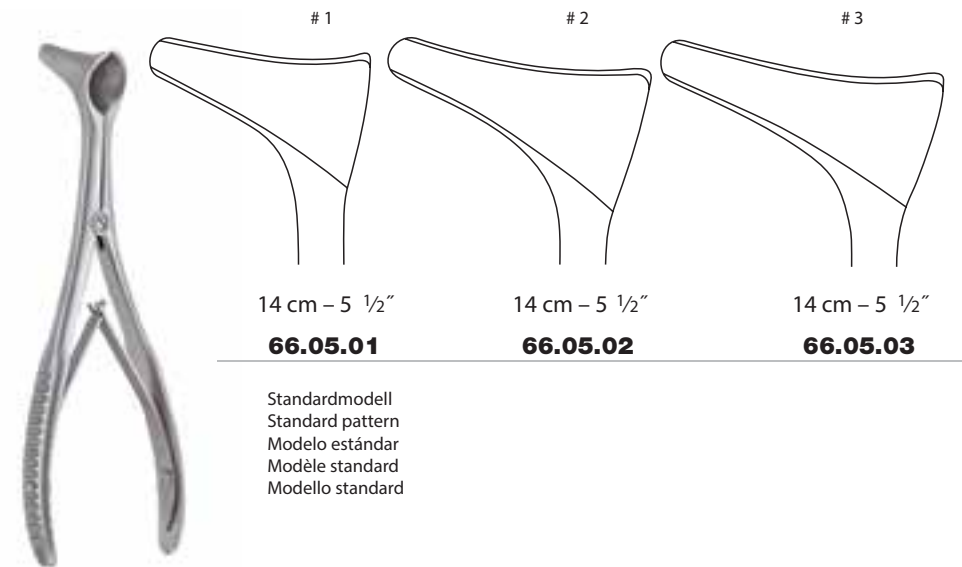
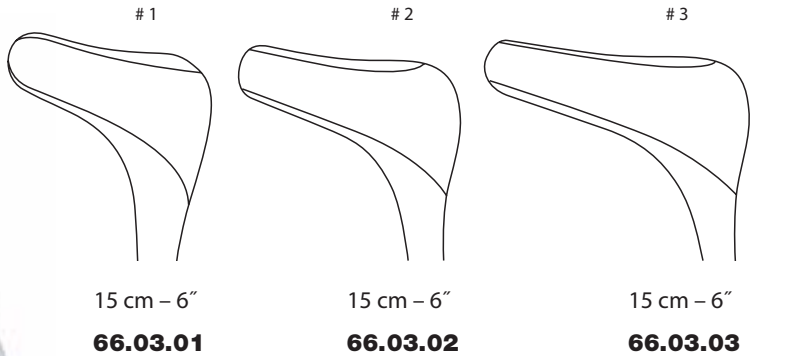

Standardmodell
Standard pattern
Modelo estándar
Modèle standard
Modello standard

Mod. Wien



TREVALLi

**Nasenspekula
Nasal Specula
Espéculos nasales
Spéculums nasaux
Specoli nasali**

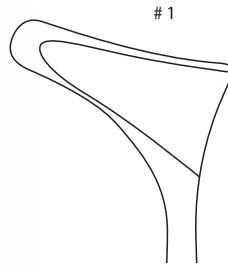

13 cm – 5 1/8"

66.05.31

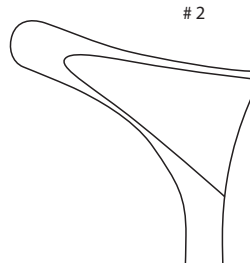

13 cm – 5 1/8"

66.05.32

leichtes Modell
light pattern
modelo ligero
modèle léger
modello leggero

Mod. Wien

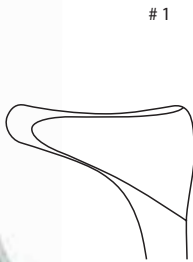

14 cm – 5 1/2"

66.05.51

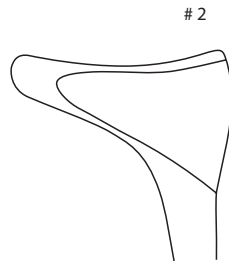

14 cm – 5 1/2"

66.05.52

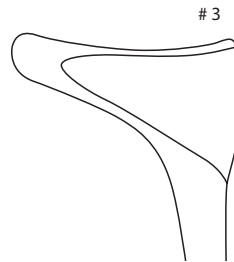

14 cm – 5 1/2"

66.05.53

Mod. Wien



14 cm – 5 1/2"

66.05.92

Einfachmodell
Simplified pattern
Modelo simplificado
Modèle simplifié
Modello semplice



TREVALLi

**Nasenspekula
Nasal Specula
Espéculos nasales
Spéculums nasaux
Specoli nasali**



Beckmann

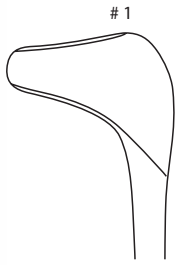

#1
15 cm – 6"
66.07.01

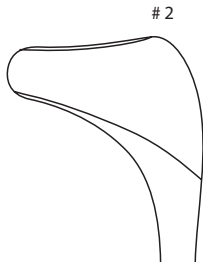

#2
15 cm – 6"
66.07.02

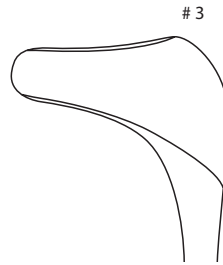

#3
15 cm – 6"
66.07.03



Beckmann

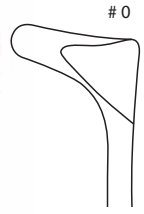

#0
13 cm – 5 1/8"
66.07.00

für Kleinkinder
for infants
para niños
pour petits enfants
per bambini



Killian

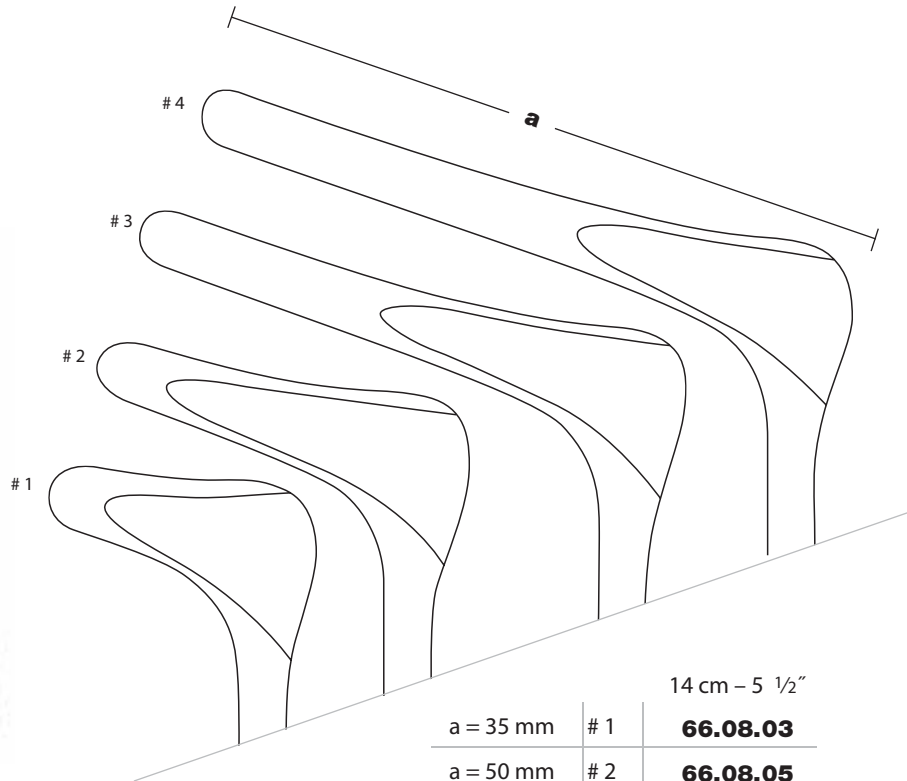

14 cm – 5 1/2"

a = 35 mm	# 1	66.08.03
a = 50 mm	# 2	66.08.05
a = 75 mm	# 3	66.08.07
a = 90 mm	# 4	66.08.09



TREVALLi

Nasenspekula
Nasal Specula
Especulos nasales
Spéculums nasaux
Specoli nasali

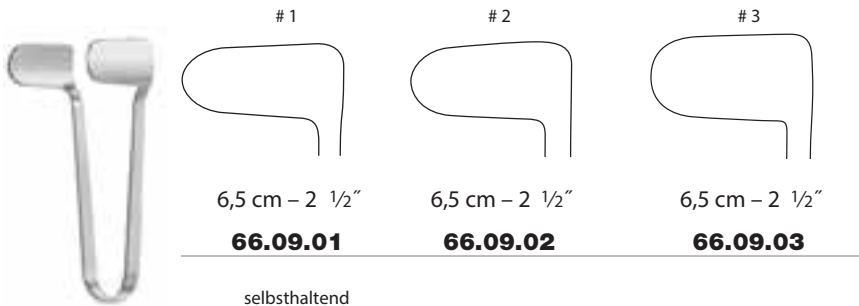

Thudichum
(Goldsmith)

selbsthaltend
 self-retaining
 autoestático
 autostatique
 autostatico

6,5 cm – 2 1/2"

66.09.01

6,5 cm – 2 1/2"

66.09.02

6,5 cm – 2 1/2"

66.09.03



Voltolini
(Duplay)

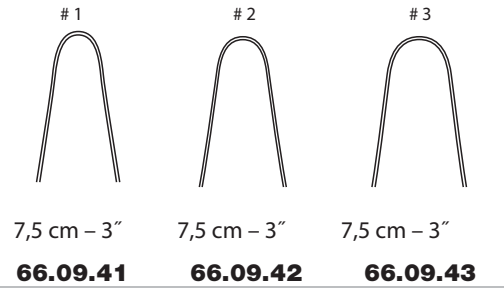

7,5 cm – 3"

66.09.41

7,5 cm – 3"

66.09.42

7,5 cm – 3"

66.09.43

selbsthaltend, Spreizung durch Stellschraube einstellbar
 self-retaining, spread adjustable by set screw
 autoestático, apertura regulable mediante tornillo de ajuste
 autostatique, écartement réglable à l'aide d'une vis d'ajustage
 autostatico, apertura regolabile mediante una vite



Killian

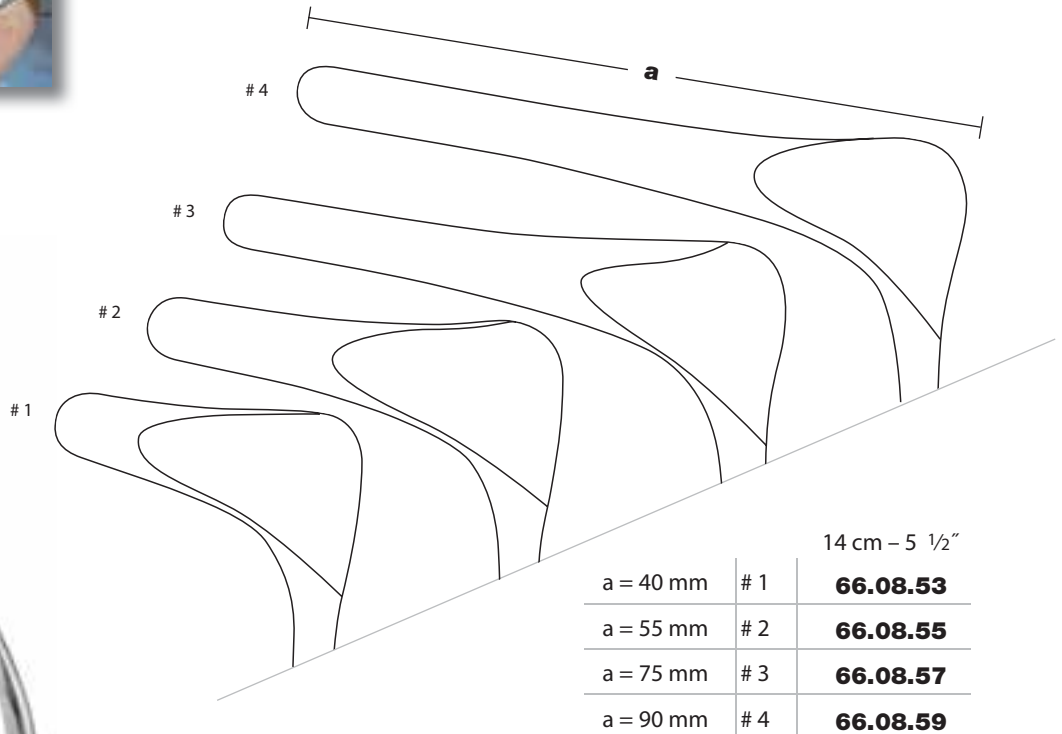

14 cm – 5 1/2"

a = 40 mm	# 1	66.08.53
a = 55 mm	# 2	66.08.55
a = 75 mm	# 3	66.08.57
a = 90 mm	# 4	66.08.59

aseptischer Verschluss (zerlegbar)
 aseptic lock (dismantable)
 articulación aséptica (desmontable)
 articulation aseptique (démontable)
 articolazione asettica (smontabile)



TREVALLi

**Nasenspekula
Nasal Specula
Espéculos nasales
Spéculums nasaux
Specoli nasali**



Cottle

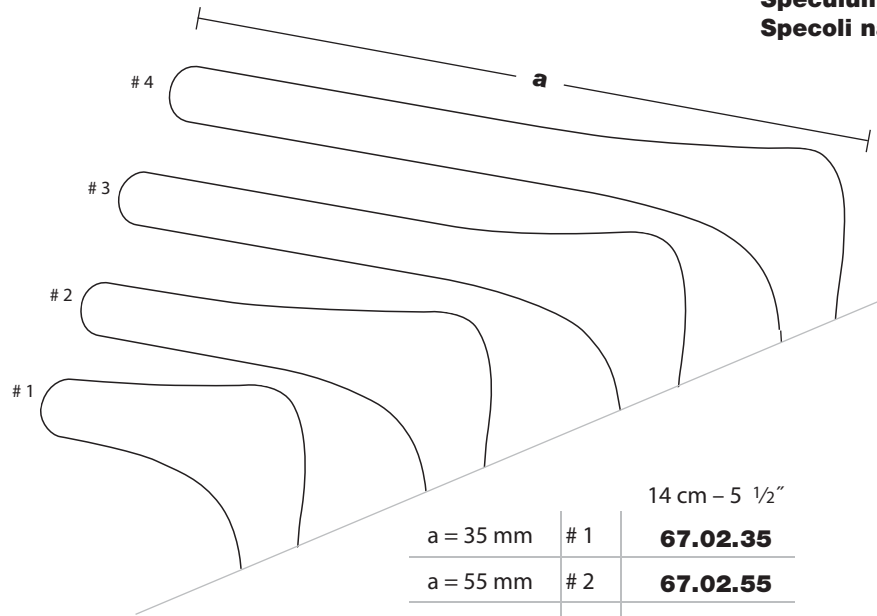

14 cm – 5 1/2"

a = 35 mm	# 1	67.02.35
a = 55 mm	# 2	67.02.55
a = 75 mm	# 3	67.02.75
a = 90 mm	# 4	67.02.90

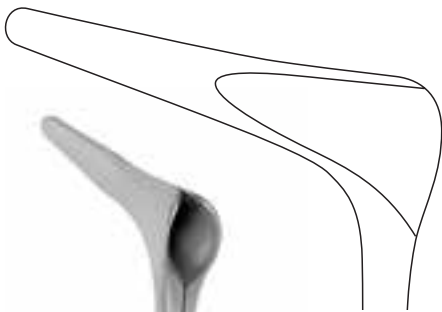

14 cm – 5 1/2"

67.03.50

Nasenseptumspekulum
Nasal septum speculum
Espéculo para el septo nasal
Spéculum pour la cloison nasale
Specolo per il setto nasale

Cottle

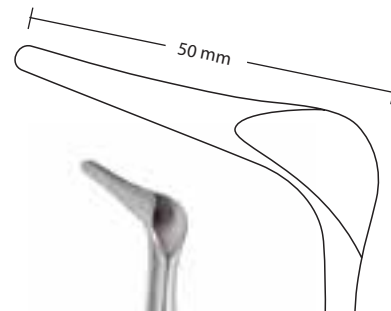

13 cm – 5 1/8"

67.03.52

Cottle



TREVALLi

Nasenspekula
Nasal Specula
Especulos nasales
Spéculums nasaux
Specoli nasali

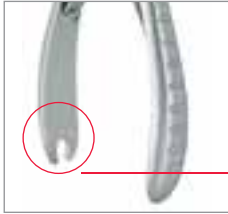

1

mit Aufnahme für Leyla Spannarm 57.59.10
with connector for Leyla holding arm 57.59.10
con adaptador para Leyla brazo tensor 57.59.10
avec adaptateur pour Leyla bras tendeur 57.59.10
con adattatore per Leyla braccio tenditore 57.59.10



2

ohne Aufnahme für Haltearm 66.10.20
without connector for holding arm 66.10.20
sin adaptador para brazo de soporte 66.10.20
sans adaptateur pour bras de support 66.10.20
senza adattatore per braccio di supporto 66.10.20



Killian

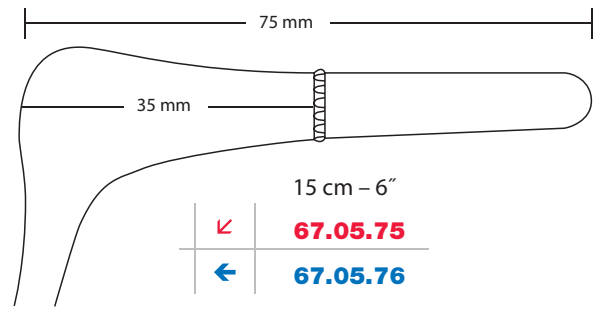
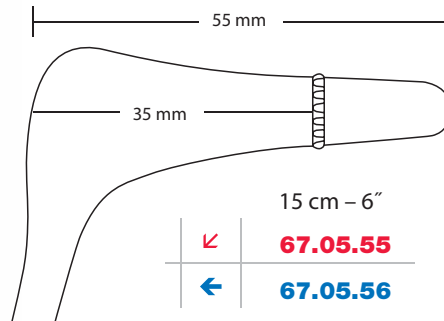

Killian

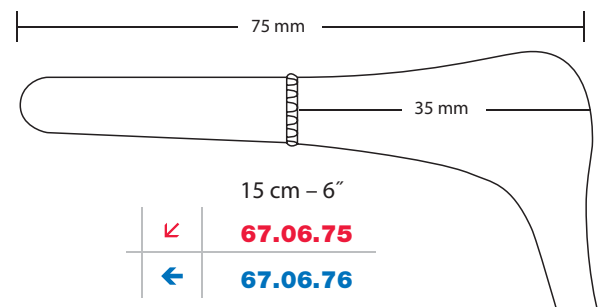
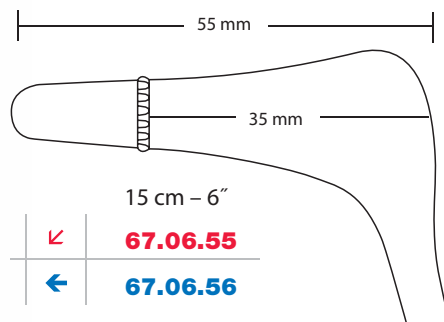



TREVALLi

Nasenspekula
Nasal Specula
Espéculos nasales
Spéculums nasaux
Specoli nasali

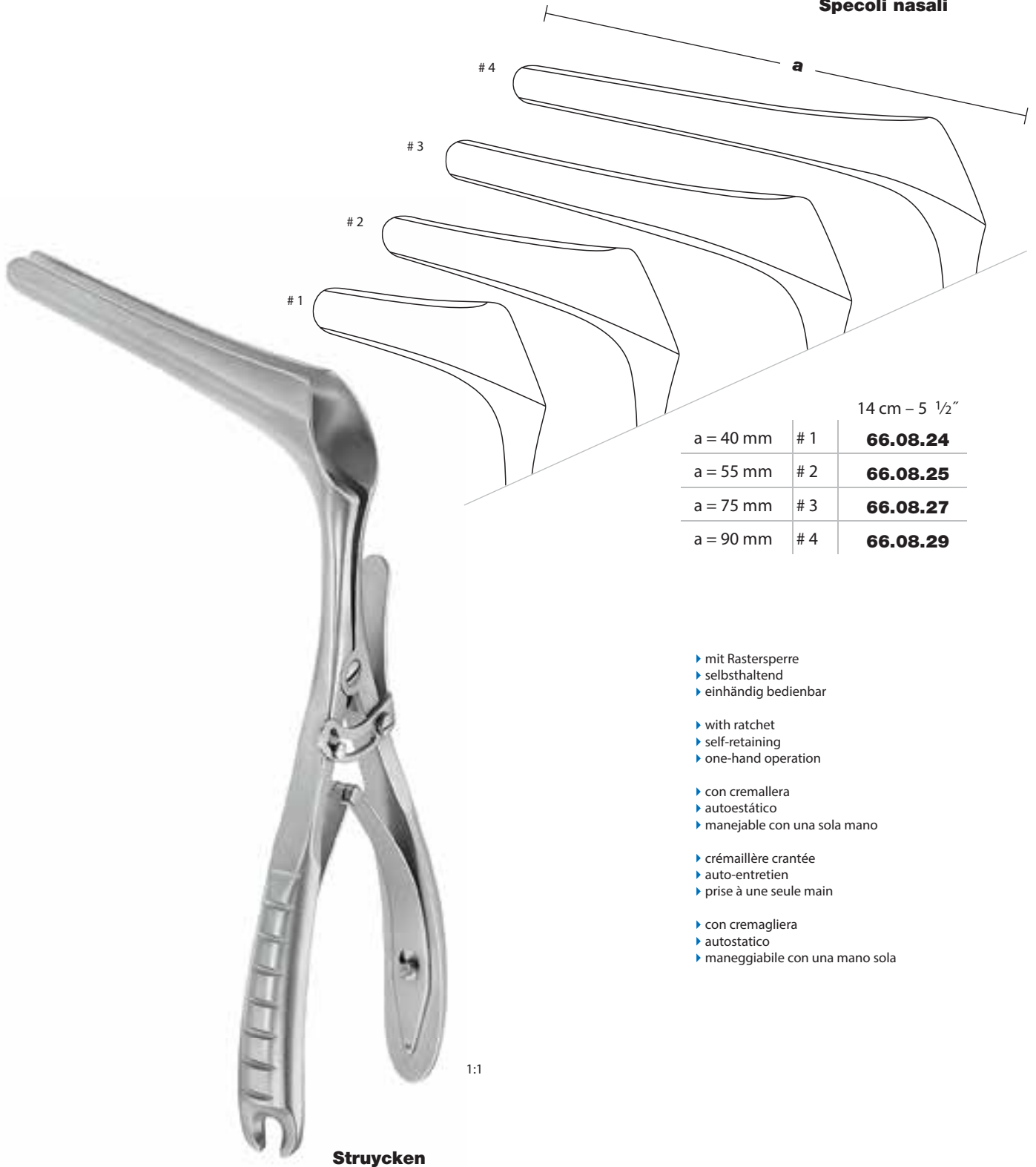

14 cm – 5 1/2"

a = 40 mm	# 1	66.08.24
a = 55 mm	# 2	66.08.25
a = 75 mm	# 3	66.08.27
a = 90 mm	# 4	66.08.29

- ▶ mit Rastersperre
- ▶ selbsthaltend
- ▶ einhändig bedienbar

- ▶ with ratchet
- ▶ self-retaining
- ▶ one-hand operation

- ▶ con cremallera
- ▶ autoestático
- ▶ manejable con una sola mano

- ▶ crémaillère crantée
- ▶ auto-entretien
- ▶ prise à une seule main

- ▶ con cremagliera
- ▶ autostatico
- ▶ maneggiabile con una mano sola

1:1

Struycken



TREVALLi

Flexibler Spannarm
Flexible Clamping Arm
Brazo tensor flexible
Bras articulé flexible
Braccio di fissaggio flessibile

zur Befestigung am Kopfbügel oder der Stange des Operationstisches
for fixation to the head bow or the bar of the operating table
para fijar al estribo de cabeza o a barra de la mesa operatoria
pour fixation au ressort de tête ou à la barre de la table d'opération
per il fissaggio al poggiatesta o alla barra del tavolo operatorio.

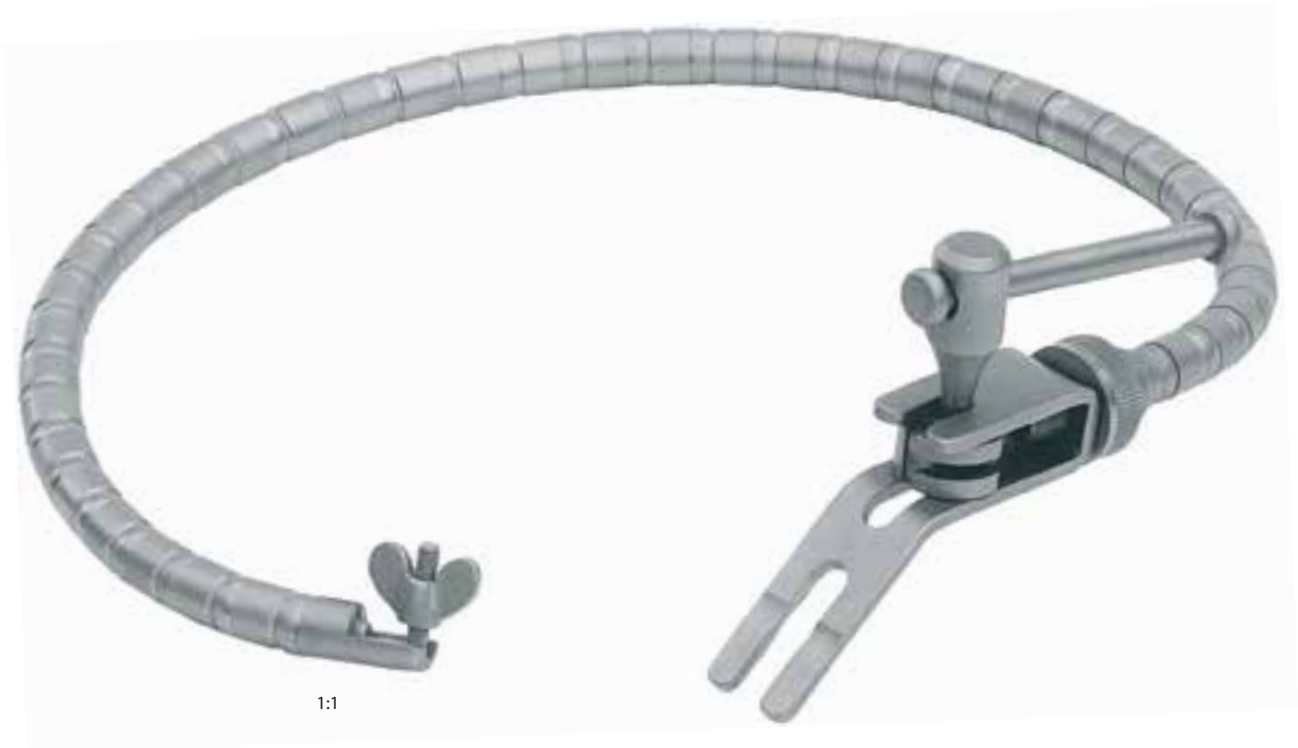

Leyla

57.59.10

Spannarm allein
Clamping arm only
Brazo tensor solo
Bras articulé seul
Braccio di fissaggio solo



57.59.26

Schraubzwinde
Fixation base
Tornillo de apriete
Serre-joint
Morsetto a vite



TREVALLI

Variable Holding Arm
Brazo de soporte variable
Bras de support variable
Braccio di supporto variabile

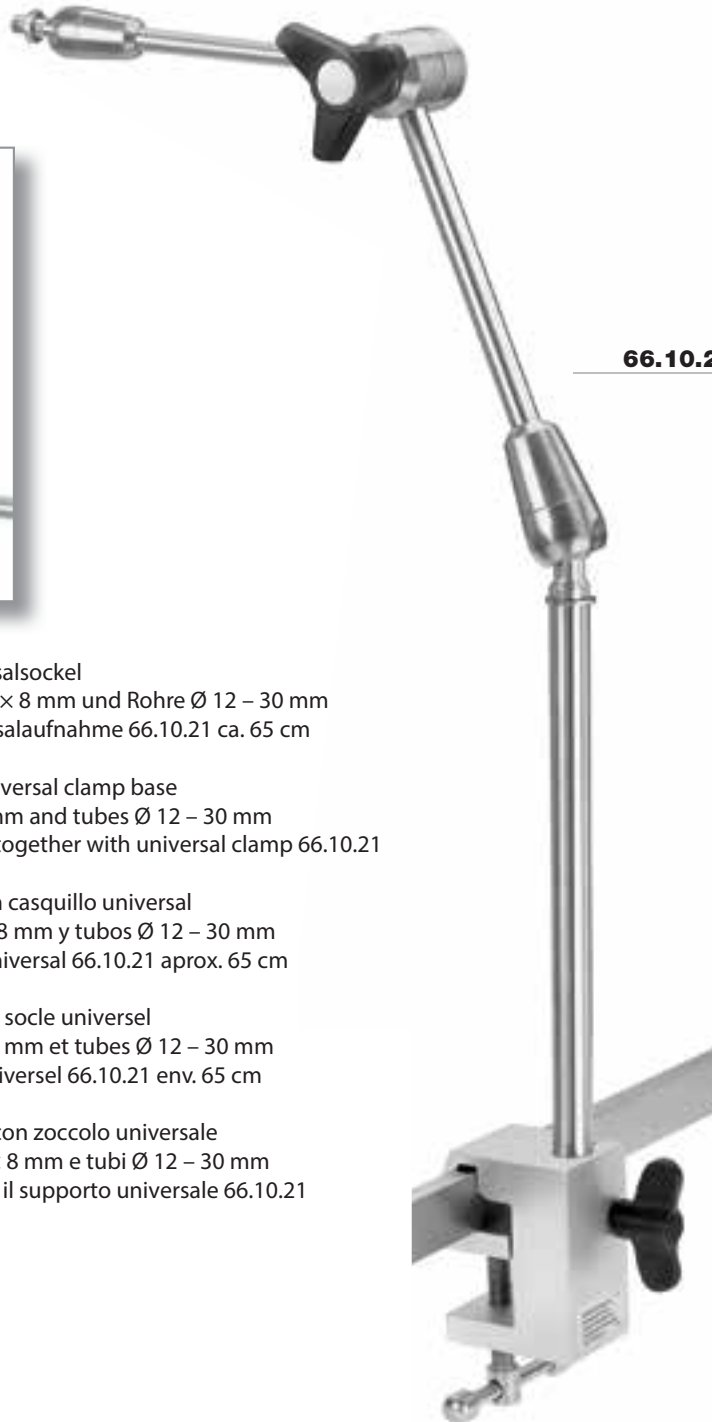

66.10.20

Medicon Haltearm mit Universalsockel
für Schienen 25 × 10 mm – 35 × 8 mm und Rohre Ø 12 – 30 mm
Gesamtlänge inklusive Universalaufnahme 66.10.21 ca. 65 cm

Medicon holding arm with universal clamp base
for rails 25 × 10 mm – 35 × 8 mm and tubes Ø 12 – 30 mm
Length overall approx. 65 cm together with universal clamp 66.10.21

Medicon brazo de soporte con casquillo universal
para rieles 25 × 10 mm – 35 × 8 mm y tubos Ø 12 – 30 mm
Longitud incluso el soporte universal 66.10.21 aprox. 65 cm

Medicon bras de support avec socle universel
pour rails 25 × 10 mm – 35 × 8 mm et tubes Ø 12 – 30 mm
Longueur totale avec socle universel 66.10.21 env. 65 cm

Medicon braccio di supporto con zoccolo universale
per lamiera 25 × 10 mm – 35 × 8 mm e tubi Ø 12 – 30 mm
La lunghezza totale compreso il supporto universale 66.10.21
è di ca. 65 cm



TREVALLi

Variabler Haltearm
Variable Holding Arm
Brazo de soporte variable
Bras de support variable
Braccio di supporto variabile



66.10.21

Universalaufnahme für diverse chirurgische Instrumente,
sowie für Optiken von Ø 2,7 – 10 mm

Universal clamp for different surgical instruments
and scopes from Ø 2,7 – 10 mm

Casquillo universal para diferentes instrumentos quirúrgicos
y para ópticas Ø 2,7 – 10 mm

Prise universelle pour instruments chirurgicaux divers
et pour optiques de Ø 2,7 – 10 mm

Presca universale per diversi strumenti chirurgici
e per ottiche di Ø 2,7 – 10 mm



66.10.22

Halter für Optik Ø 4 mm
Holder for endoscope Ø 4 mm
Fijacion para óptica Ø 4 mm
Fixation pour l'optique Ø 4 mm
Fissaggio per ottica Ø 4 mm



66.10.23

Halter für Optik Ø 10 mm
Holder for endoscope Ø 10 mm
Fijacion para óptica Ø 10 mm
Fixation pour l'optique Ø 10 mm
Fissaggio per ottica Ø 10 mm



TREVALLi

Nasen-Polypenschnürer
Nasal Polypus Snares
Polipotomos nasales
Serre-nœud pour polypes du nez
Serranodi per polipi nasali



25 cm – 10"
66.15.10

Wilde (Brünings)



26 cm – 10 1/4"
66.15.20

Krause

Ersatzteile für Instrumente:
Spare parts for instruments:
Piezas de repuesto para instrumentos:
Pièces de rechange pour instruments:
Pezzi di ricambio per strumenti:

Stilett (Drahtführer) allein Stilet (wire guide) only Estilete (guía-hilo) solo Stylet (guide-anse) seul Stiletto (guida-filo) solo	66.15.10	66.15.20
	66.15.13	66.15.23
Rohraufsatz allein Cannula only Terminal tubular solo Embout tubulaire seul Tubo terminale solo		66.15.21



TREVALLI

Schnürerdrähte, Nasentamponzangen
Snare Wires, Nasal Dressing Forceps
Alambres para cierranudos, Pinzas nasales para tamponamiento
Fils pour serre-nœud, Pincès à pansements pour le nez
Fili per serranodi, Pinze per tamponamento nasale



Ø 0,35 mm Ø 0,40 mm Ø 0,45 mm
66.15.43 66.15.44 66.15.45

Schnürerdrähte
 Snare wires
 Alambres para cierranudos
 Fils pour serre-nœud
 Fili per serranodi

Rolle zu 10 Meter
 Coil 10 m (33.3 ft.)
 Rollo de 10 m
 Rouleau de 10 m
 Rotolo da 10 m



Ø 0,3 mm

66.15.40

Schnürerdrähte, vorgeformt
 Snare wires, preshaped
 Alambres para cierranudos, preformados
 Fils pour serre-nœud, préformées
 Fili per serranodi, preformati

Bündel zu 100 Stück
 Bundle of 100 pieces
 Atado de 100 piezas
 Botte de 100 pièces
 Confezione da 100 pezzi



18 cm – 7 1/8"

66.20.10

feines Modell
 delicate pattern
 modelo fino
 modèle fin
 modello fine

Hartmann



20 cm – 8"

66.20.11

Standardmodell
 Standard pattern
 Modelo estándar
 Modèle standard
 Modello standard

Hartmann



TREVALLi

Nasentamponzangen
Nasal Dressing Forceps
Pinzas nasales para tamponamiento
Pinces à pansements pour le nez
Pinze per tamponamento nasale

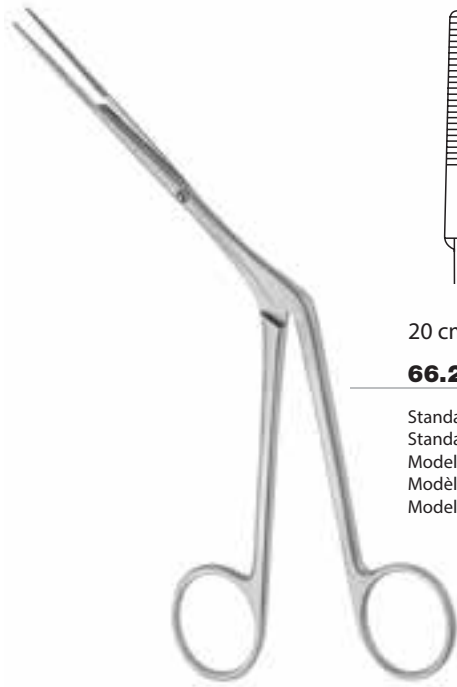

Westmacott



20 cm – 8"

66.20.25

Standardmodell
Standard pattern
Modelo estándar
Modèle standard
Modello standard



20 cm – 8"

66.20.27

Feines Modell
Delicate pattern
Modelo fino
Modèle fin
Modello fine



Lubet-Barbon



20 cm – 8"

66.20.28

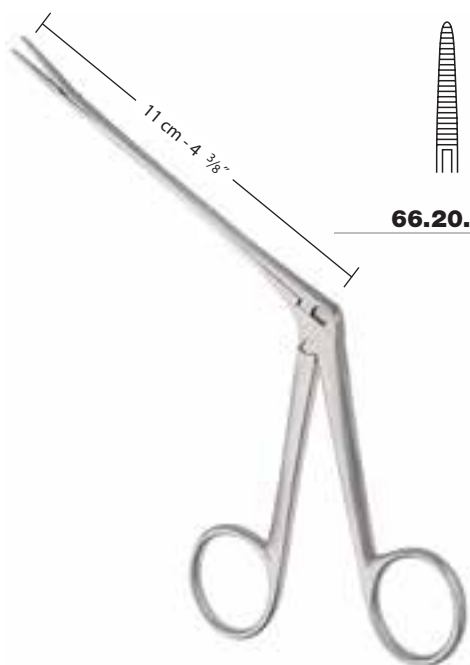

Noyes



66.20.30



Noyes



66.20.31



TREVALLi

Nasentamponzange, Nasenseptumzangen
Nasal Dressing Forceps, Nasal Septum Forceps
Pinza nasal para tamponamiento, Pinzas para el tabique nasal
Pince à pansements pour le nez, Pincés pour la cloison nasale
Pinza per tamponamento nasale, Pinze per il setto nasale



17 cm – 6 ¾"

66.20.35

Tilley

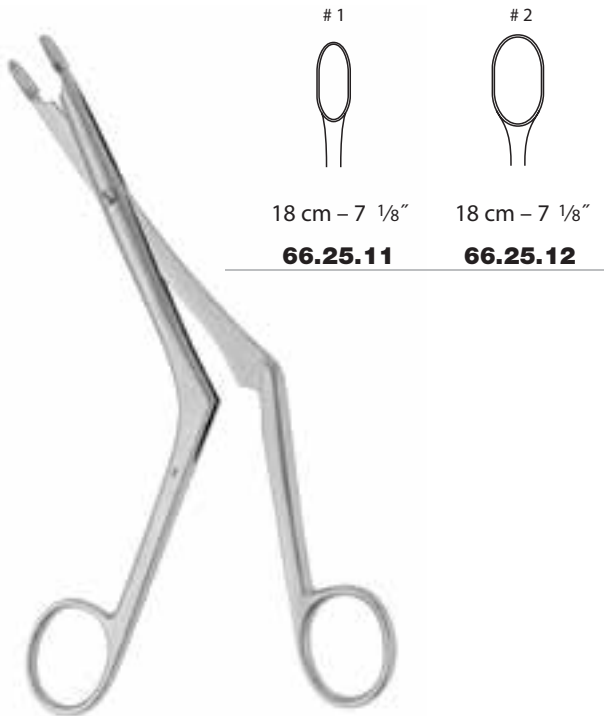

1

2

18 cm – 7 1/8"

18 cm – 7 1/8"

66.25.11

66.25.12

**Luc-Brünings
(Heymann)**



17 cm – 6 ¾"

66.25.15

Vomerzange
 Vomer forceps
 Pinza para el vómer
 Pince à vomer
 Pinza per vomere

Craig



TREVALLi

Nasenseptumzangen
Nasal Septum Forceps
Pinzas para el tabique nasal
Pinces pour la cloison nasale
Pinze per il setto nasale

1



19 cm - 7 1/2"

66.25.01

2



19 cm - 7 1/2"

66.25.02

3



19 cm - 7 1/2"

66.25.03



Brünings



Knight

19 cm - 7 1/2"

66.25.10

1



19 cm - 7 1/2"

66.27.11

2



19 cm - 7 1/2"

66.27.12

3



19 cm - 7 1/2"

66.27.13

Siebbeinzangen
Ethmoid bone forceps
Pinzas para hueso etmoides
Pinces pour os ethmoidal
Pinze per osso etmoidale



17 cm - 6 3/4"

66.25.16



17 cm - 6 3/4"

66.25.17

Vomerzangen
Vomer forceps
Pinzas para el vómer
Pinces à vomer
Pinze per vomere



Craig-Domnick



Luc



TREVALLi

**Nasenseptumzangen
Nasal Septum Forceps
Pinzas para el tabique nasal
Pinces pour la cloison nasale
Pinze per il setto nasale**

11,5 cm - 4 1/2"



Ferris-Smith



66.25.40

Sequesterzange
Sequestrum forceps
Pinza para secuestrectomía
Pince à séquestre
Pinza per sequestri

12 cm - 4 3/4"



Blakesley



66.25.45

12 cm - 4 3/4"



Blakesley



66.25.51



TREVALLi

Nasenseptumzangen
Nasal Septum Forceps
Pinzas para el tabique nasal
Pinces pour la cloison nasale
Pinze per il setto nasale



Watson-Williams

Siebbeinzange
Ethmoid bone forceps
Pinza para hueso etmoides
Pince pour os ethmoïdal
Pinza per osso etmoidale



Jansen-Middleton

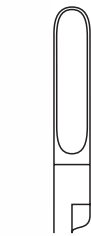

19 cm - 7 1/2"
66.25.60



Jansen-Middleton

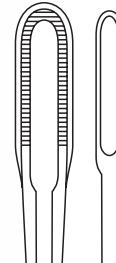

19 cm - 7 1/2"
66.25.65

Nasenseptumstanze
Nasal septum rongeur
Pinza saca-bocada para el tabique nasal
Pince emporte-pièce pour le septum nasal
Pinza tagliente per il setto nasale



TREVALLi

Nasenseptumzangen
Nasal Septum Forceps
Pinzas para el tabique nasal
Pinces pour la cloison nasale
Pinze per il setto nasale

Septumrichtzangen
 Septum straightening forceps
 Pinzas para enderezar el tabique nasal
 Pinces pour le redressement de la cloison nasale
 Pinze per rizzare il setto nasale

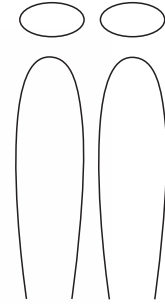

23 cm - 9"

67.65.10

Walsham "Universal"

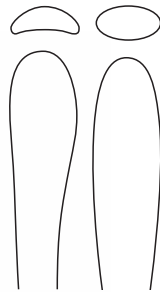

23 cm - 9"

67.65.11

rechts
 right
 derecha
 droite
 destra

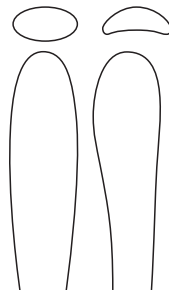

23 cm - 9"

67.65.12

links
 left
 izquierda
 gauche
 sinistra



Walsham



TREVALLi

Nasenseptumzangen
Nasal Septum Forceps
Pinzas para el tabique nasal
Pinces pour la cloison nasale
Pinze per il setto nasale



Septum-Zerschneider
Septum cutter
Cortador del septo
Pince perforatrice de la cloison nasale
Pinza tagliente per il setto nasale

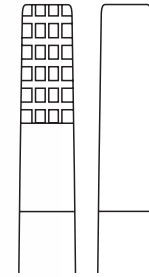
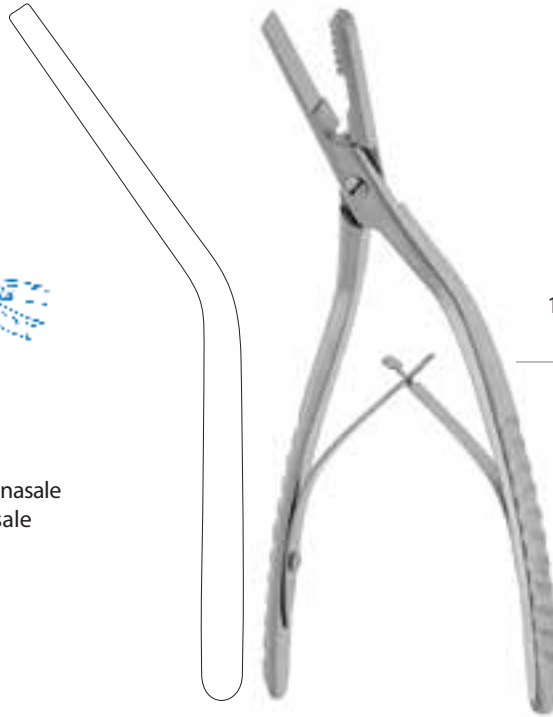

18,5 cm - 7 1/4"

67.65.18

Obwegeser



22 cm - 8 3/4"

67.65.20

Asch

Septumrichtzange
Septum straightening forceps
Pinza para enderezar el tabique nasal
Pince pour le redressement de la cloison nasale
Pinze per rizzare il setto nasale



21 cm - 8 1/4"

67.65.24

Kressner



TREVALLi

Knorpelklemme
Cartilage Forceps
Pinza para cartilago
Pince à cartilage
Pinza per cartilagine

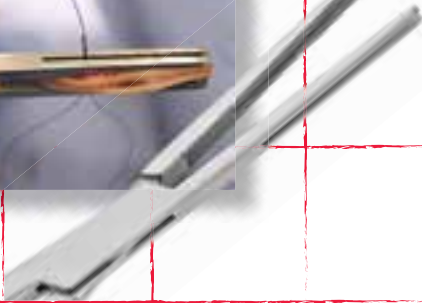

Aiach

Mehrschichtige Knorpeltransplantate können exakt miteinander vernäht werden.

Allows an exact suture of multilayered cartilage transplants.

Injertos de cartilago de varias capas pueden ser suturadas entre ellos más precisamente.

Des implants de cartilage à plusieurs couches peuvent être suturés exactement l'un avec l'autre.

Trapianti di cartilagine stratificati possono essere ricuciti esattamente l'un con l'altro.

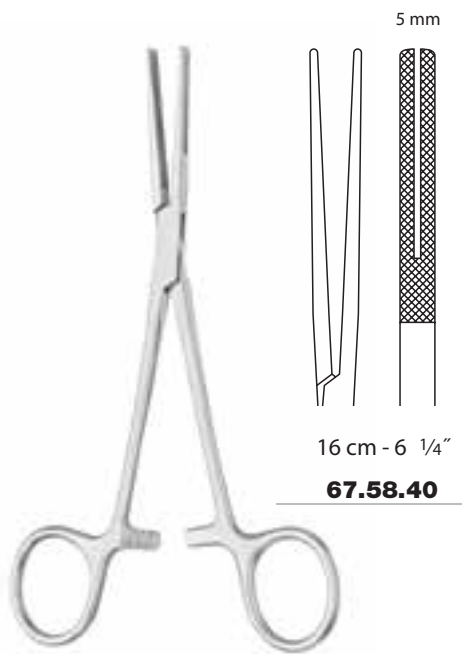

Aiach



Aiach-Gubisch



TREVALLi

**Quetschzangen
Morselizer Forceps
Pinzas para aplastamiento
Pinces pour presser et pour aplatissement
Pinze appiattimento**

Die Neutralisation der Knorpelspannung ermöglicht Neukonturierung des Knorpels ohne Beeinträchtigung der Knorpelstruktur.
Neutralisation of tension in the cartilage permits recontouring of the cartilage without impairment to the cartilage structure.
La neutralización de la tensión del cartilago permite su nuevo contorneado sin afectar a la estructura del mismo.
La neutralisation de la tension du cartilage permet de refaire le contour du cartilage sans nuire à la structure cartilagineuse.
La neutralizzazione della tensione cartilaginea permette di definire un nuovo contorno della cartilagine senza comprometterne la struttura.

Septum-Quetschzangen
mit Schutzkappe

Septal morselizer forceps
with protective cap

Pinzas para aplastamiento
el tabique nasal con
caperuza protectora

Pinces pour aplatissement
de la cloison nasale avec
capuchon protecteur

Pinze per appiattimento
del setto nasale con
cappuccio di protezione



20 cm - 8"
67.65.70

Rubin



20 cm - 8"
67.65.72

Gubisch-Rubin "HM"

Schutzkappe
Protective cap
Caperuza protectora
Capuchon protecteur
Cappuccio di protezione



67.65.71

Die Schutzkappe kann je nach Bedarf auf rechtes oder linkes
Maulteil umgesteckt werden.

According to the requirements of operation, the cap may be
placed either on the right or the left jaw.

En caso de necesidad, la caperuza protectora puede colocarse
sobre la parte derecha o la parte izquierda de la boca de la pinza.

Selon le besoin, le capuchon protecteur se posera sur le mors
droit ou sur le mors gauche.

Il cappuccio può essere applicato indifferentemente sul morso
destro oppure sinistro.

"HM"

Hartmetall
Tungsten carbide
Carburo de tungsteno
Carbure de tungstène
Carburo di tungsteno



TREVALLi

Quetschzangen
Morselizer Forceps
Pinzas para aplastamiento
Pinces pour presser et pour aplatissement
Pinze per appiattimento

Septum-Quetschzangen
Septal morselizer forceps
Pinzas para aplastamiento el tabique nasal
Pinces pour aplatissement de la cloison nasale
Pinze per appiattimento del setto nasale



20 cm - 8"
67.65.74

Rubin



20 cm - 8"
67.65.76

Rubin "HM"



25 x 20 mm

19 cm - 7 1/2"
67.65.80

Tschoepe

Schutzkappe
Protective cap
Caperuza protectora
Capuchon protecteur
Cappuccio di protezione



1:1

67.65.71

Die Schutzkappe kann je nach Bedarf auf rechtes oder linkes Maulteil umgesteckt werden.

According to the requirements of operation, the cap may be placed either on the right or the left jaw.

En caso de necesidad, la caperuza protectora puede colocarse sobre la parte derecha o la parte izquierda de la boca de la pinza.

Selon le besoin, le capuchon protecteur se posera sur le mors droit ou sur le mors gauche.

Il cappuccio può essere applicato indifferentemente sul morso destro oppure sinistro.

"HM"

Hartmetall
Tungsten carbide
Carburo de tungsteno
Carbure de tungstène
Carburo di tungsteno



TREVALLi

Nasenzangen
Nasal Forceps
Pinzas nasales
Pinces nasales
Pinze nasali

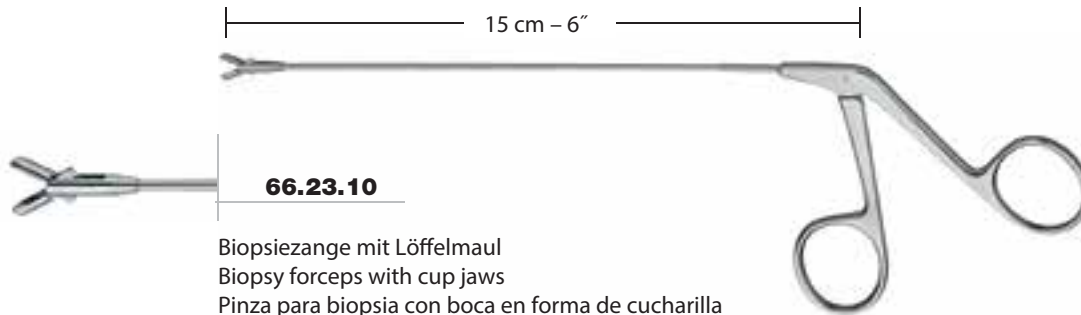

66.23.10

Biopsiezange mit Löffelmaul
 Biopsy forceps with cup jaws
 Pinza para biopsia con boca en forma de cucharilla
 Pince à biopsie avec mors en forme de cuiller
 Pinza per biopsia con morso a forma di cucchiaio

Schaft
 Shaft
 Vástago
 Tige
 Asta

Ø **1,5** mm

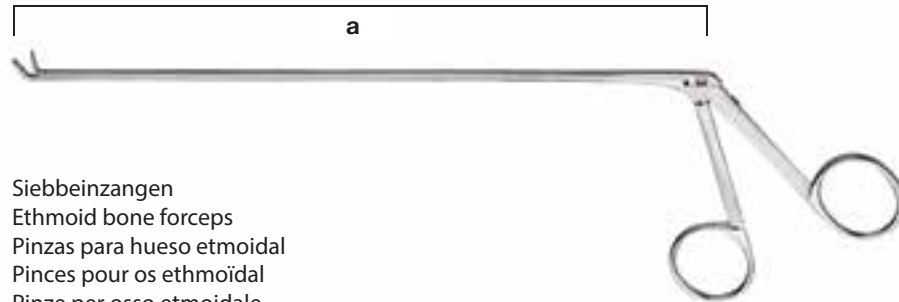

Siebbeinzangen
 Ethmoid bone forceps
 Pinzas para hueso etmoidal
 Pinces pour os ethmoidal
 Pinze per osso etmoidale

Strümpel

	gerade straight recta droit retta	aufgewinkelt angled upwards angulado hacia arriba coudé en haut angolata verso l'alto	aufgewinkelt angled upwards angulado hacia arriba coudé en haut angolata verso l'alto
a = 13 cm - 5 1/8"	66.23.13	66.23.23	66.23.33
a = 16 cm - 6 1/4"	66.23.16	66.23.26	66.23.36
a = 19 cm - 7 1/2"	66.23.19	66.23.29	66.23.39



TREVALLi

Nasenzangen
Nasal Forceps
Pinzas nasales
Pinces nasales
Pinze nasali



66.25.57

Kieferhöhlen-Fasszange
Maxillary sinus grasping forceps
Pinza para agarrar el seno maxilar
Pince pour saisir le sinus maxillaire
Pinza da presa per seno mascellare

Schaft
Shaft
Vástago
Tige
Asta

Ø **2,5** mm

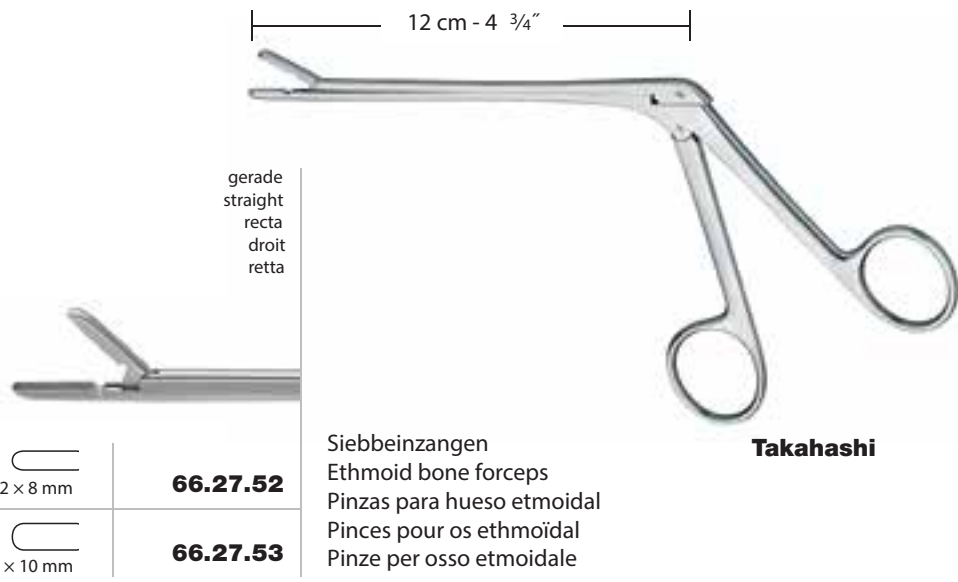

Siebbeinzangen
Ethmoid bone forceps
Pinzas para hueso etmoidal
Pinces pour os ethmoïdal
Pinze per osso etmoidale

Takahashi



2 x 8 mm

66.27.52



3 x 10 mm

66.27.53



TREVALLi

**Nasenzangen
Nasal Forceps
Pinzas nasales
Pincas nasales
Pinze nasali**

12 cm - 4 3/4"



Weil-Blakesley

Siebbeinzangen
Ethmoid bone forceps
Pinzas para hueso etmoidal
Pincas pour os ethmoïdal
Pinze per osso etmoidale



mit normalem Schaft
with normal shaft
con vástago normal
à tige normale
con asta normale

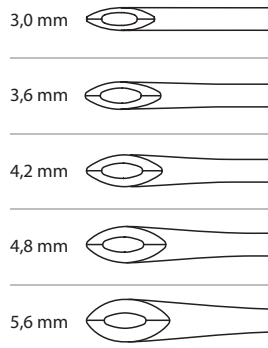

gerade
straight
recta
droit
retta

aufgewinkelt
angled upwards
angulado hacia arriba
coudé en haut
angolata verso l'alto

aufgewinkelt
angled upwards
angulado hacia arriba
coudé en haut
angolata verso l'alto



66.28.01
1

66.28.11
1

66.28.31
1

66.28.02
2

66.28.12
2

66.28.32
2

66.28.03
3

66.28.13
3

66.28.33
3

66.28.04
4

66.28.14
4

66.28.34
4

66.28.05
5



mit schlankem Schaft
with slim shaft
con vástago delgado
à tige élancée
con asta sottile

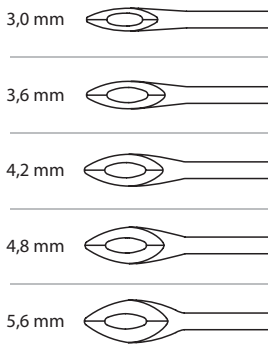

66.28.71
1

66.28.81
1

66.28.72
2

66.28.82
2

66.28.73
3

66.28.83
3

66.28.74
4

66.28.84
4

66.28.75
5



TREVALLi

**Nasenzangen
Nasal Forceps
Pinzas nasales
Pinces nasales
Pinze nasali**

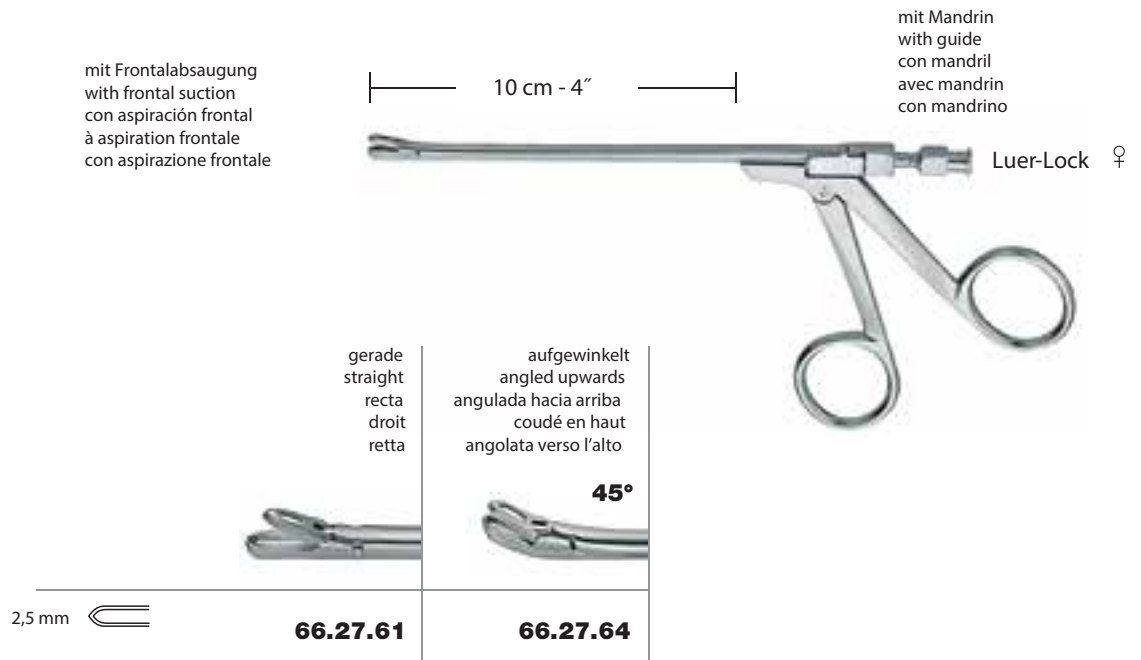
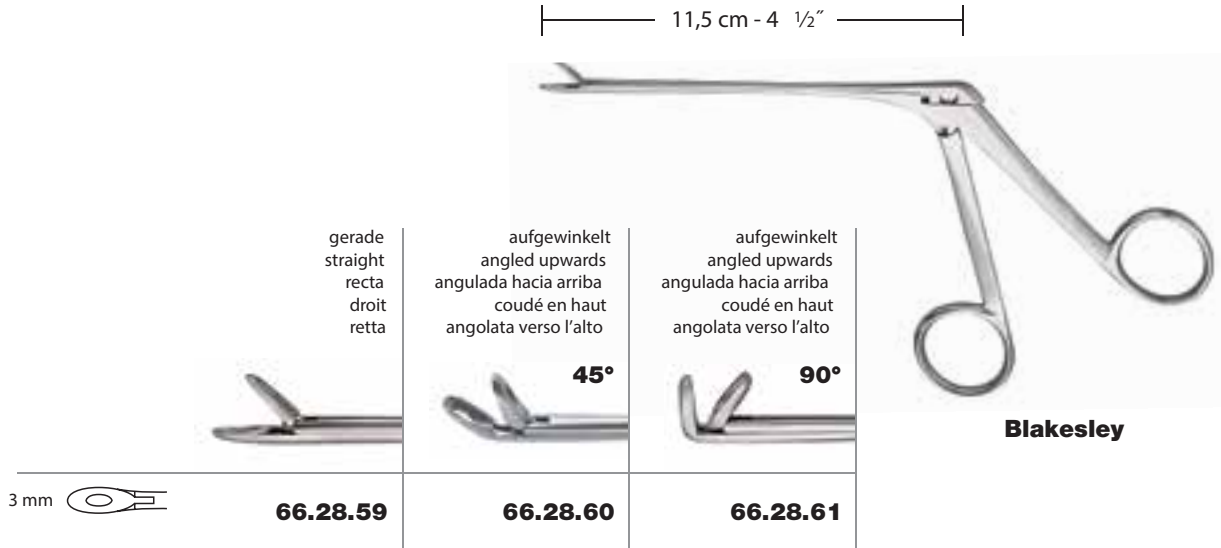



TREVALLi



10 cm - 4"



gerade
straight
recta
droit
retta

aufgewinkelt
angled upwards
angulada hacia arriba
coudé en haut
angolata verso l'alto

45°

Takahashi

2,5 mm



3,5 mm



66.27.56

66.27.58

66.27.57

66.27.59

Schaft
Shaft
Vástago
Tige
Asta

Ø 4 mm

**Nasenzangen
Nasal Forceps
Pinzas nasales
Pinces nasales
Pinze nasali**

10 cm - 4"



gerade
straight
recta
droit
retta

aufgewinkelt
angled upwards
angulada hacia arriba
coudé en haut
angolata verso l'alto

45°

Weil-Blakesley

2,5 mm



66.28.40

66.28.50

3,5 mm



66.28.41

66.28.51

4,0 mm



66.28.42

66.28.52

Schaft
Shaft
Vástago
Tige
Asta

Ø 4,0 mm

Ø 4,0 mm

Ø 5,0 mm



mit Absaugung
with suction
con aspiración
avec aspiration
con aspirazione



TREVALLI

Nasenzangen
Nasal Forceps
Pinzas nasales
Pinces nasales
Pinze nasali

Polypenfasszangen
 Polyp grasping forceps
 Pinzas para agarrar pólipos
 Pinces à polypes
 Pinze da presa per polipi

|----- 13 cm - 5 1/8" -----|

aufgewinkelt
angled upwards
angulada hacia arriba
coudé en haut
angolata verso l'alto

80°



66.29.00

aufgewinkelt
angled upwards
angulada hacia arriba
coudé en haut
angolata verso l'alto

45°



66.29.03

Luer-Lock ♀



Schaft
Shaft
Vástago
Tige
Asta

Ø 2,7 mm

|----- 13 cm - 5 1/8" -----|

vertikal öffnend
vertical opening
apertura vertical
ouverture verticale
apertura verticale

55°

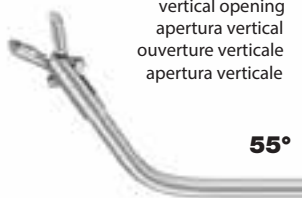



66.29.10

horizontal öffnend
horizontal opening
apertura horizontal
ouverture horizontale
apertura orizzontale

55°



66.29.11

2 mm 	66.29.12	66.29.13
3 mm 	66.29.14	66.29.15
4 mm 		

Luer-Lock ♀

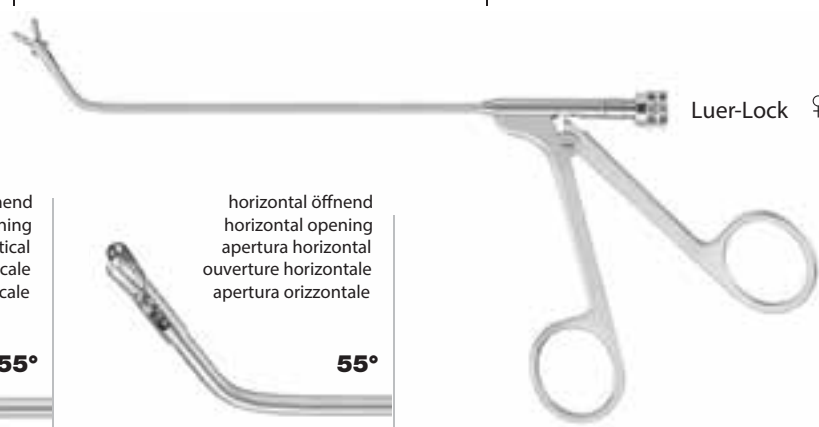

Schaft
Shaft
Vástago
Tige
Asta

Ø 2,7 mm



TREVALLi

Nasenzangen
Nasal Forceps
Pinzas nasales
Pinces nasales
Pinze nasali

13 cm - 5 1/8"

Luer-Lock ♀

vertikal öffnend
vertical opening
apertura vertical
ouverture verticale
apertura verticale

90°

2 mm ○ **66.29.36**

horizontal öffnend
horizontal opening
apertura horizontal
ouverture horizontale
apertura orizzontale

90°

66.29.37

Schaft
Shaft
Vástago
Tige
Asta

Ø **2,7 mm**

13 cm - 5 1/8"

Luer-Lock ♀

vertikal öffnend
vertical opening
apertura vertical
ouverture verticale
apertura verticale

110°

4 mm ○ **66.29.40**

horizontal öffnend
horizontal opening
apertura horizontal
ouverture horizontale
apertura orizzontale

110°

66.29.41

Schaft
Shaft
Vástago
Tige
Asta

Ø **2,7 mm**



TREVALLi

**Nasenzangen
Nasal Forceps
Pinzas nasales
Pinces nasales
Pinze nasali**

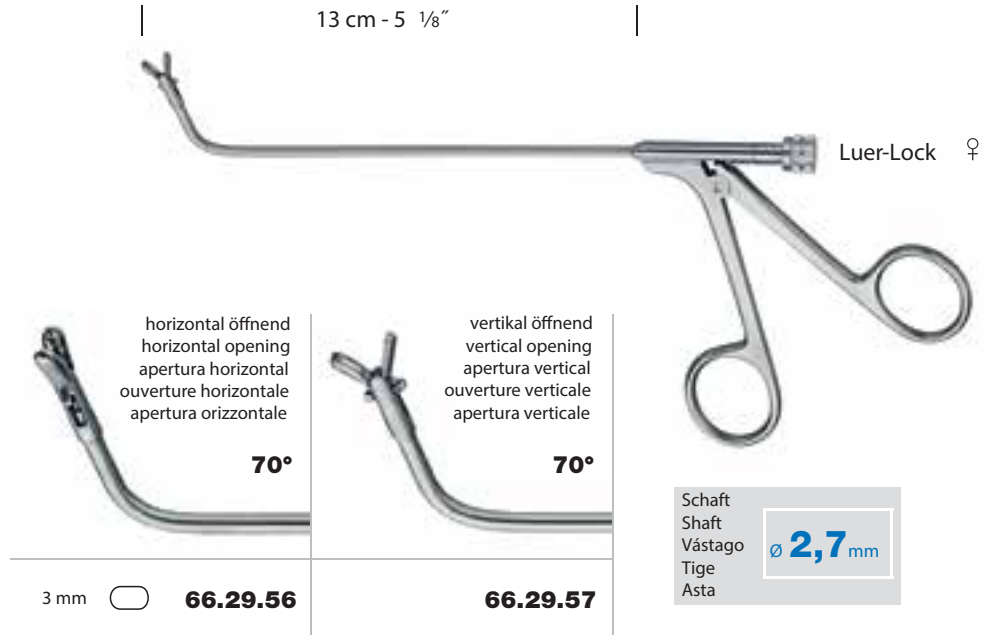

Kieferhöhlen-Probeexzisionszangen
Maxillary sinus biopsy forceps
Pinzas para excisión de prueba en el seno maxilar
Pinces à excision d'épreuves pour le sinus maxillaire
Pinze per l'esame bioptico del seno mascellare

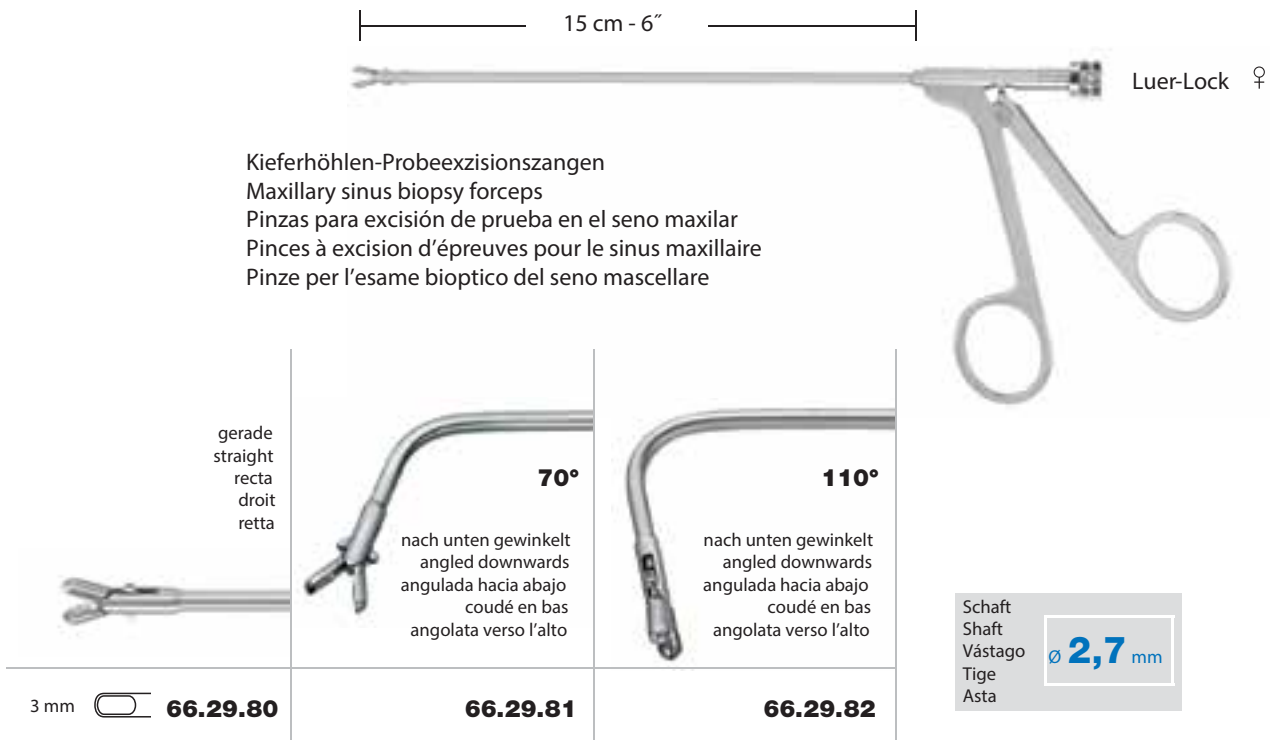



TREVALLI

Nasenzangen durchschneidend
Nasal Forceps through-cutting
Pinzas nasales cortantes
Pinces nasales coupantes
Pinze nasali taglienti

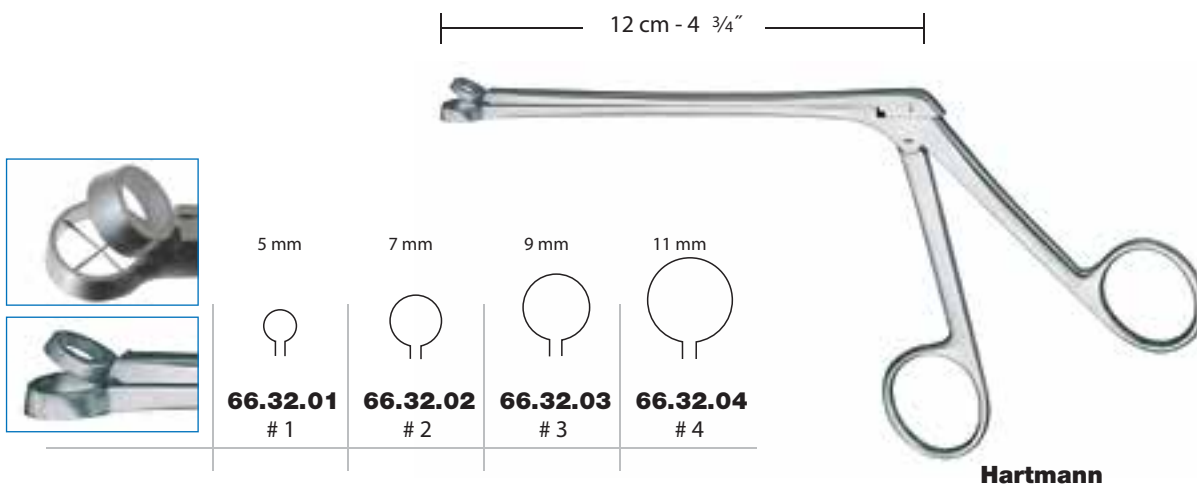
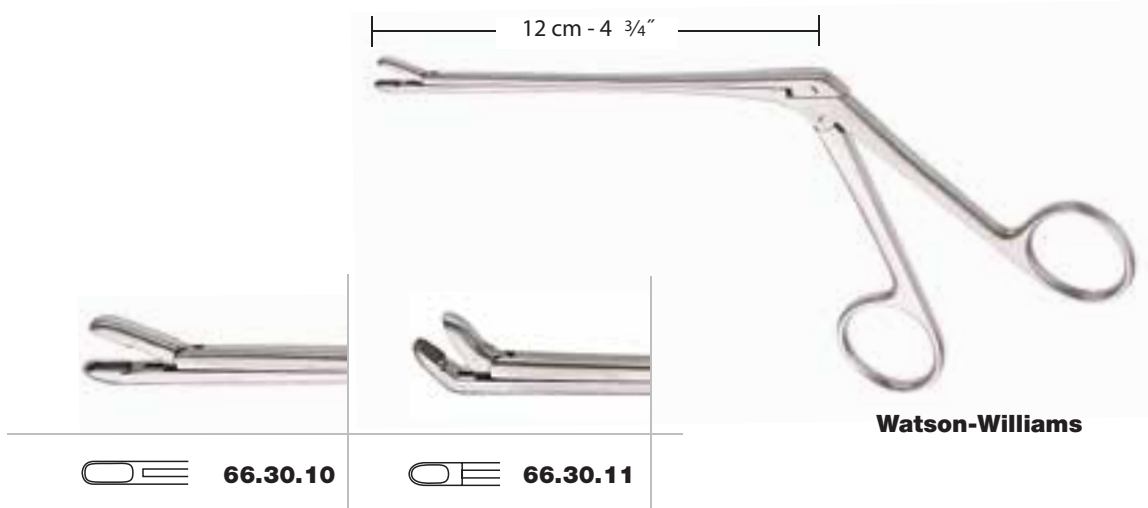



TREVALLi

Nasenzangen durchschneidend
Nasal Forceps through-cutting
Pinzas nasales cortantes
Pinces nasales coupantes
Pinze nasali taglienti

Siebbeinzangen
Ethmoid bone forceps
Pinzas para hueso etmoidal
Pinces pour os ethmoidal
Pinze etmoidali

12 cm - 4 3/4"



Watson-Williams

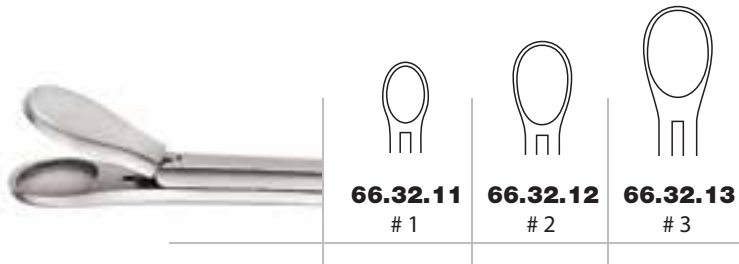

12 cm - 4 3/4"



Schmeden

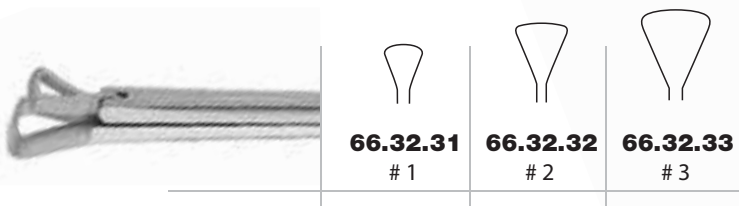



TREVALLI

Nasenzangen durchschneidend
Nasal Forceps through-cutting
Pinzas nasales cortantes
Pinces nasales coupantes
Pinze nasali taglienti

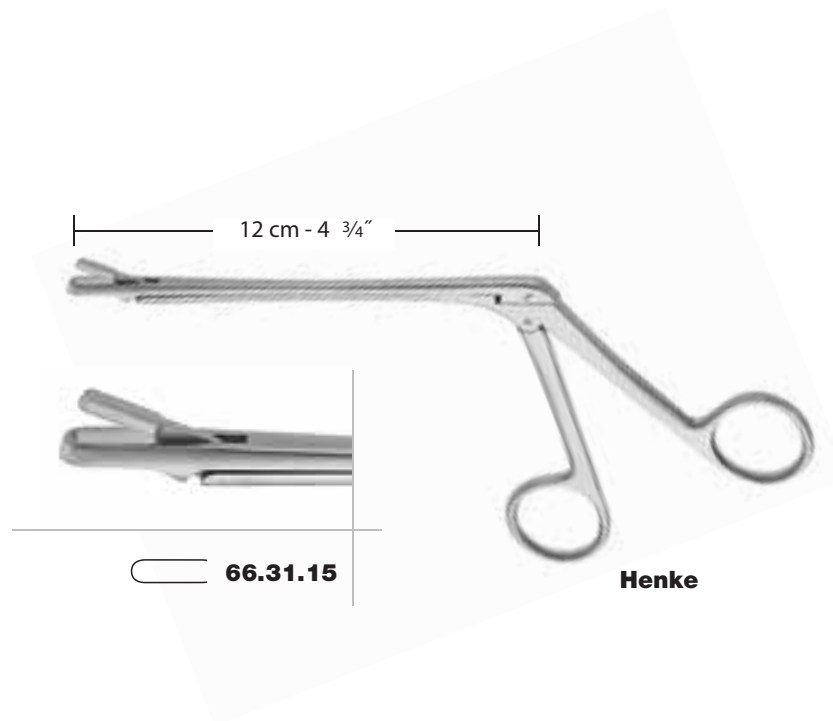



TREVALLi

Nasenzangen durchschneidend
Nasal Forceps through-cutting
Pinzas nasales cortantes
Pinces nasales coupantes
Pinze nasali taglianti

12 cm - 4 3/4"

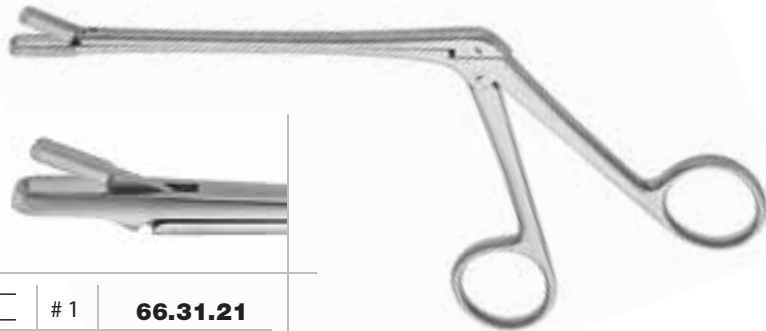

	# 1	66.31.21
	# 2	66.31.22
	# 3	66.31.23

Hajek-Gruenwald

12 cm - 4 3/4"



	# 1	66.31.31
	# 2	66.31.32
	# 3	66.31.33
	# 4	66.31.34

Myles



TREVALLi

Nasenzangen durchschneidend
Nasal Forceps through-cutting
Pinzas nasales cortantes
Pinces nasales coupantes
Pinze nasali taglienti

11,5 cm - 4 1/2"



gerade
straight
recta
droit
retta

aufgewinkelt
angled upwards
angulada hacia arriba
coudé en haut
angolata verso l'alto

45°



Weil-Blakesley

2,0 mm		66.28.06	66.28.15
2,5 mm		66.28.07	66.28.16
3,0 mm		66.28.08	66.28.17

12 cm - 4 3/4"

Turbinektomiezeange
Turbinectomy forceps
Pinza para turbinectomia
Pince à turbinectomie
Pinza per turbinectomia



 **66.28.21**



Fanous



TREVALLi

Nasenzangen durchschneidend
Nasal Forceps through-cutting
Pinzas nasales cortantes
Pinces nasales coupantes
Pinze nasali taglienti

14 cm - 5 1/2"



Gruenwald

11,5 cm - 4 1/2"



rechts gebogen
curved right
curva derecha
courbé à droite
curva a destra

links gebogen
curved left
curva izquierda
courbé à gauche
curva a sinistra



30°



30°

2,5 mm  **66.28.23**

66.28.24

Schaft
Shaft
Vástago
Tige
Asta

Ø **3,4 mm**

Luer-Lock ♀

Weil-Blakesley

10 cm - 4"



mit Frontalabsaugung
with frontal suction
con aspiración frontal
à aspiration frontale
con aspirazione frontale

mit Mandrin
with guide
con mandril
avec mandrin
con mandrino

2,0 mm  **66.27.67**

2,5 mm  **66.27.68**

Luer-Lock ♀





TREVALLi

Nasenzangen durchschneidend
Nasal Forceps through-cutting
Pinzas nasales cortantes
Pinces nasales coupantes
Pinze nasali taglienti

13 cm - 5 1/8"

Luer-Lock ♀

vertikal öffnend vertical opening apertura vertical ouverture verticale apertura verticale	90°	horizontal öffnend horizontal opening apertura horizontal ouverture horizontale apertura orizzontale	90°
 2 mm	66.29.75		66.29.76
 3 mm	66.29.77		66.29.78



Schaft
 Shaft
 Vástago
 Tige
 Asta

∅ 2,7 mm

13 cm - 5 1/8"

Luer-Lock ♀

Gruenwald

gerade straight recta droit retta		aufgewinkelt angled upwards angulada hacia arriba coudé en haut angolata verso l'alto	45°
2,0 mm  6,0 mm	66.31.40		66.31.43
2,5 mm  7,0 mm	66.31.41		66.31.44
3,0 mm  7,5 mm	66.31.42		66.31.45

Schaft
 Shaft
 Vástago
 Tige
 Asta

∅ 3,4 mm



TREVALLi

Nasenscheren
Nasal Scissors
Tijeras nasales
Ciseaux nasaux
Forbici nasali

gezahnte Schneide
serrated cutting edge
hoja dentada
lames dentelée
lame dentellate



Heymann



17 cm - 6 3/4"

66.40.20

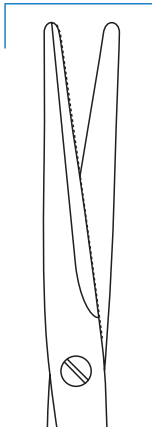

17 cm - 6 3/4"

66.40.21



18 cm - 7 1/8"

266.40.21

standard

supercut



Heymann

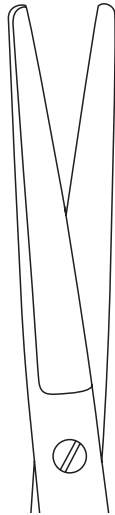

20 cm - 8"

66.40.22

standard



Seiler

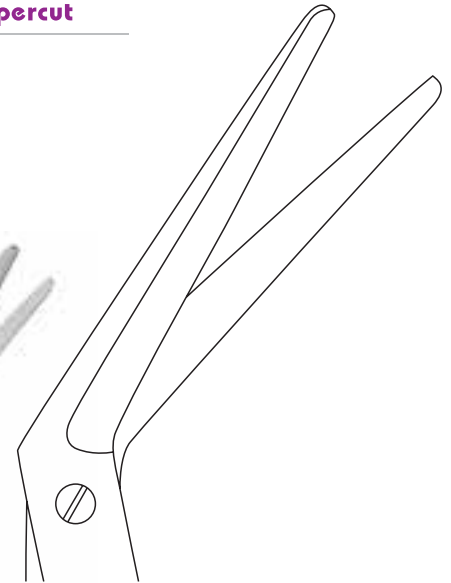

17 cm - 6 3/4"

66.40.05

standard



TREVALLi

Nasenscheren
Nasal Scissors
Tijeras nasales
Ciseaux nasaux
Forbici nasali

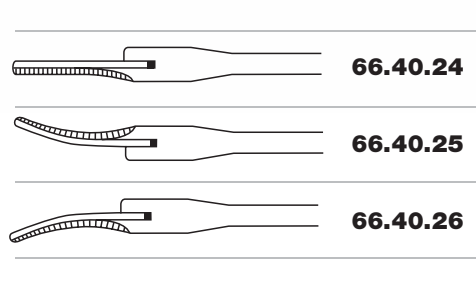
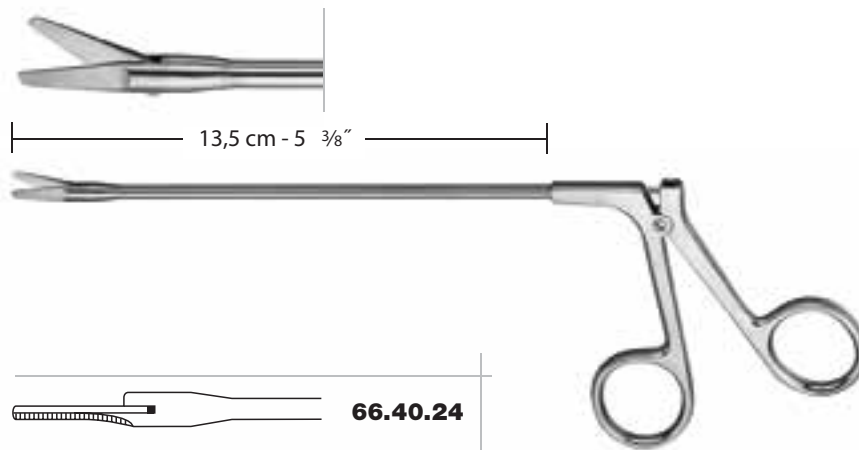
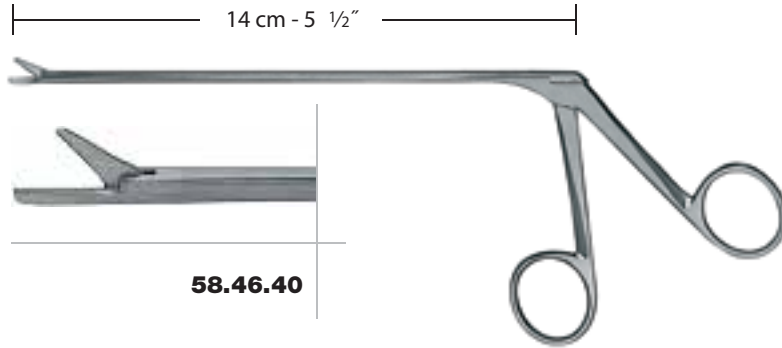

Schaft
Shaft
Vaina
Tige
Guaina

Ø 3,5 mm



TREVALLI

Nasenschere
Nasal Scissors
Tijera nasal
Ciseaux nasaux
Forbice nasale

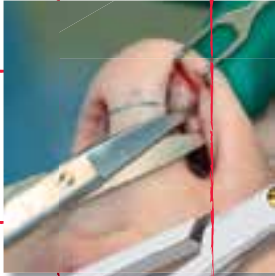

204.55.66
Kelly supercut plus

Ideal für die Präparation sowohl des Weichgewebes als auch der Knorpelstrukturen.
Ideal for the preparation of soft tissue as well as cartilaginous structures.
Ideal para la disección de los tejidos blandos, así como de las estructuras cartilagineas.
Idéal pour la préparation à la fois du tissu mou et des structures cartilagineuses.
Ideale per la preparazione del tessuto molle e delle strutture di cartilagine.

Präparierschere
Dissecting scissors
Tijera para disección
Ciseaux à dissection
Forbice per dissezione



20 cm - 8"

204.55.66 **supercut plus**

Kelly



TREVALLI

**Nasenscheren
Nasal Scissors
Tijeras nasales
Ciseaux nasaux
Forbici nasali**



10 cm - 4"

67.48.10

10 cm - 4"

67.49.10

standard

Cottle-Masing

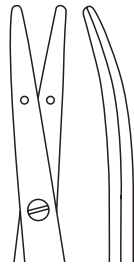

12 cm - 4 3/4"

67.50.01

Fadenführungsschere
Suture carrying scissors
Tijera guía-hilo
Ciseaux guide-fil
Forbice guida filo

standard

Littler



11,5 cm - 4 3/4"

67.50.11

Bulldogschere
Bulldog scissors
Tijera Bulldog
Ciseaux Bulldog
Forbice Bulldog

standard

Cottle

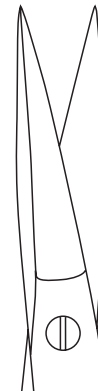

13,5 cm - 5 3/8"

67.50.13

Außenkanten halbscharf
Outer edges semisharp
Bordes exteriores semicortantes
Bords extérieurs semi-tranchants
Bordi esterni semitaglienti

standard

Converse



TREVALLi

Nasenscheren
Nasal Scissors
Tijeras nasales
Ciseaux nasaux
Forbici nasali

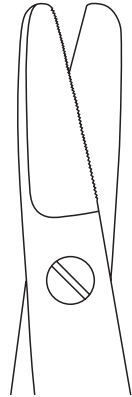

Facelift

16 cm - 6 1/4"

67.50.16

standard

Castanares

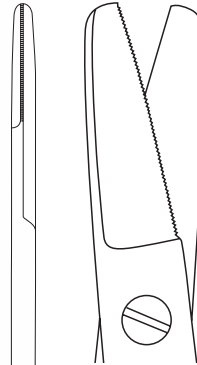

Facelift

16 cm - 6 1/4"

67.51.16

standard

Walter-Castanares

mit Außenschliff, beidseitig schneidend
with outer cutting, both sides sharp
con afilado exterior, cortante en ambos lados
avec affûtage extérieur, coupant des deux côtés
con affilatura esterna, tagliente da ambedue i lati

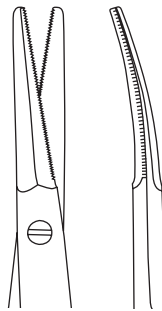

12,5 cm - 5"

67.51.12

standard

Fomon

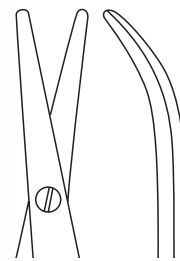

11 cm - 4 3/8"

67.52.11

standard

Cinelli



TREVALLi

Nasenscheren
Nasal Scissors
Tijeras nasales
Ciseaux nasaux
Forbici nasali

Außenkanten halbscharf, gezahnte Schneiden
Outer edges semisharp, serrated cutting edges
Bordes exteriores semicortantes, hoja dentadas
Bords extérieurs semi-tranchants, lames dentelées
Bordi esterni semitaglienti, lame dentellate

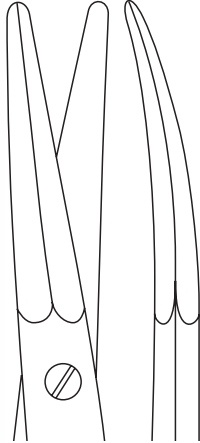

mit Außenschliff, beidseitig schneidend
with outer cutting, both sides sharp
con afilado exterior, cortante en ambos lados
avec affûtage extérieur, coupant des deux côtés
con affilatura esterna, tagliente da ambedue i lati

14 cm - 5 1/2"

67.51.14 standard

267.51.14 supercut

277.51.14 black line

67.51.64 "HM"

267.51.64 supercut plus

Aufricht

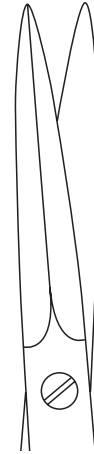

19 cm - 7 1/2"

67.51.19 standard

McIndoe

Knorpelschere
Cartilage scissors
Tijera para cartílagos
Ciseaux à cartilage
Forbice per cartilagine

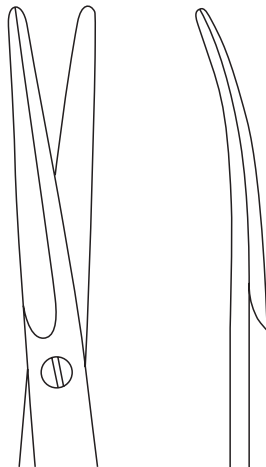

Unterminierscheren
Undermining scissors
Tijeras para tunelización
Ciseaux à tunnellation
Forbice per tunnelizzare

18,5 cm - 7 1/4"

67.49.18

20,0 cm - 8"

67.49.20

standard

Obwegeser



TREVALLI

**Nasenscheren
Nasal Scissors
Tijeras nasales
Ciseaux nasaux
Forbici nasali**



12 cm - 4 3/4"

- | | |
|------------------|-------------------|
| 67.52.12 | standard |
| 267.52.12 | supercut |
| 277.52.12 | black line |

Fomon

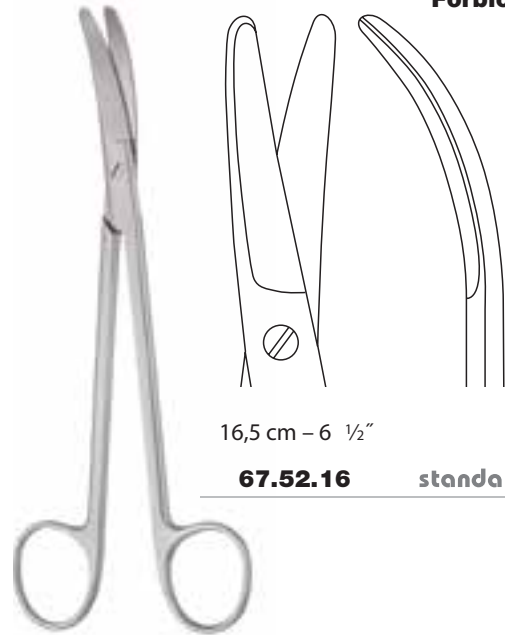

16,5 cm - 6 1/2"

- | | |
|-----------------|-----------------|
| 67.52.16 | standard |
|-----------------|-----------------|

Joseph



13 cm - 5 1/8"

- | | |
|------------------|----------------------|
| 67.53.13 | standard |
| 267.53.13 | supercut |
| 267.53.63 | supercut plus |
| 227.53.63 | magic cut |

Fomon



14 cm - 5 1/2"

- | | |
|------------------|-----------------|
| 267.53.14 | supercut |
|------------------|-----------------|

Walter



TREVALLi

Nasenscheren
Nasal Scissors
Tijeras nasales
Ciseaux nasaux
Forbici nasali

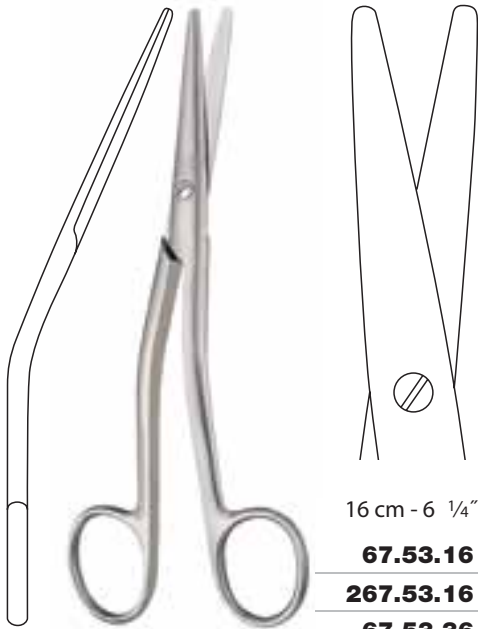

Cottle

16 cm - 6 1/4"

67.53.16 standard

267.53.16 supercut

67.53.36 "HM"

267.53.36 supercut plus

227.53.36 magic cut

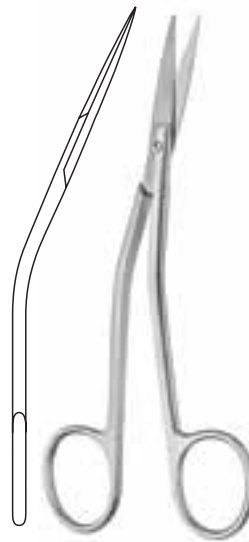

Fanous

14 cm - 5 1/2"

67.53.23 standard

267.53.23 supercut

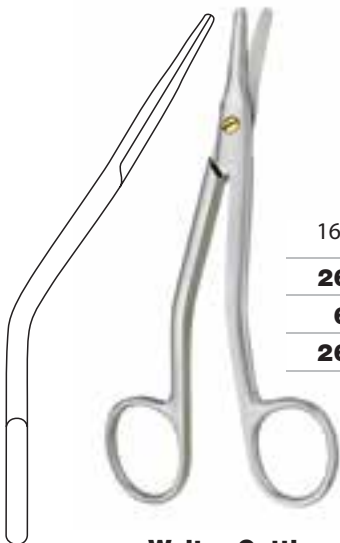

Walter-Cottle

16 cm - 6 1/4"

267.53.17 supercut

67.53.77 "HM"

267.53.77 supercut plus



Winter

9,5 cm - 3 3/4"

67.53.80 standard



TREVALLI

**Nasenscheren
Nasal Scissors
Tijeras nasales
Ciseaux nasaux
Forbici nasali**



Cottle

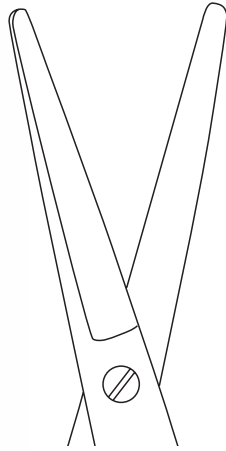

18 cm - 7 1/8"

67.53.50

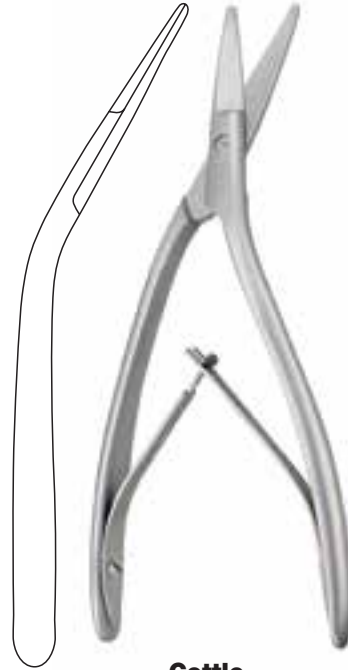

Cottle

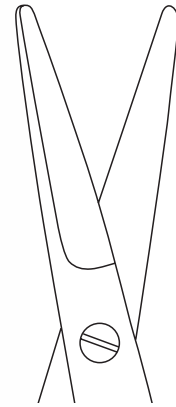

18 cm - 7 1/8"

67.53.51

Nasenseptumschere
Nasal septum scissors
Tijera para el tabique nasal
Ciseaux pour cloison nasale
Forbice per setto nasale

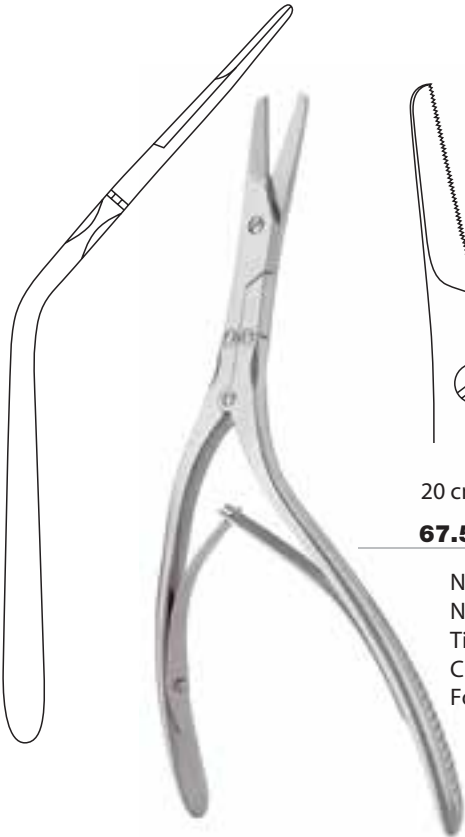

Caplan

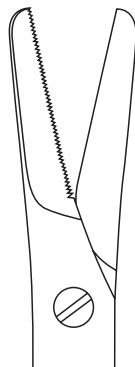

20 cm - 8"

67.53.71

Nasenseptumschere
Nasal septum scissors
Tijera para el tabique nasal
Ciseaux pour cloison nasale
Forbice per setto nasale

← gezahnte Schneiden
serrated cutting edges
hojas dentadas
lames dentelées
lame dentellate →

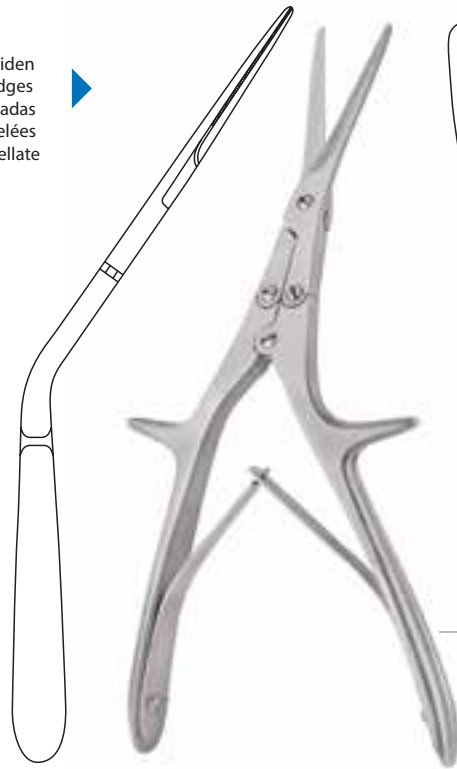

Gorney

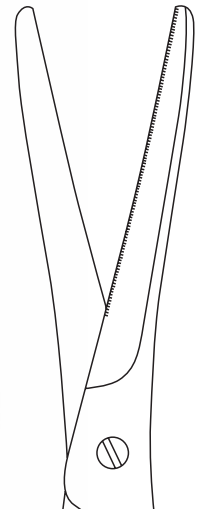

20 cm - 8"

67.53.75



TREVALLi

Nasenscheren
Nasal Scissors
Tijeras nasales
Ciseaux nasaux
Forbici nasali

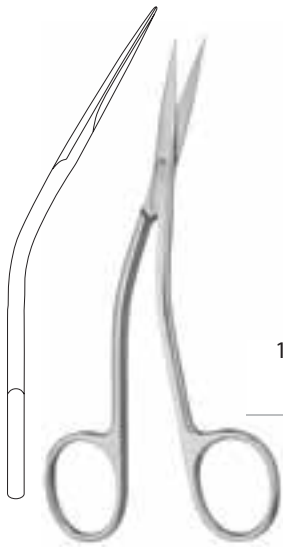

Hough



13 cm - 5 1/8"

67.53.83 **standard**



Giunta



13,5 cm - 5 3/8"

67.55.63 **"HM"**
227.55.63 **magic cut**



Obwegeser

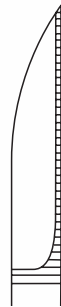

21 cm - 8 1/4"

67.65.31

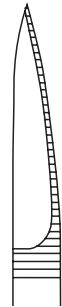

21 cm - 8 1/4"

67.65.32



21 cm - 8 1/4"

67.65.33

Nasenrückenscheren
Nasal bridge scissors
Tijeras para dorso nasal
Ciseaux pour le dos nasal
Forbici per dorso nasale



TREVALLI

Nasensattelstanzen
Nasal Saddle Punches
Pinzas saca-bocadas nasales
Pinces emporte-pièce de la bosse nasale
Pinze nasali

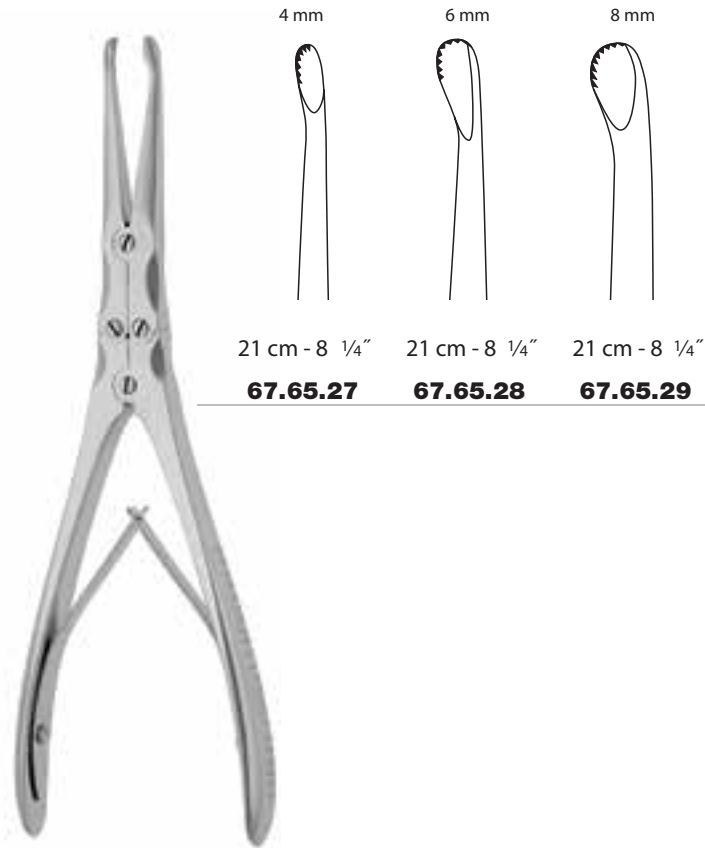

4 mm

6 mm

8 mm

21 cm - 8 1/4"

21 cm - 8 1/4"

21 cm - 8 1/4"

67.65.27

67.65.28

67.65.29

Obwegeser

Zur Reduzierung des Winkels zwischen Nase und Stirn.
Dies wird durch delikates Abbeißen (Nagen) des Knochens bewerkstelligt.

For the reduction of the angle between nose and forehead
by delicate biting of the bone.

Para reducir el ángulo entre nariz y frente a
través de morder delicadamente el hueso.

Utilisées pour la réduction de l'angle entre le nez et le front,
en arrachant l'os d'une façon délicate.

Per la riduzione dell'angolo tra naso e fronte.
Questo avviene tramite un delicato rosicchiare dell'osso.

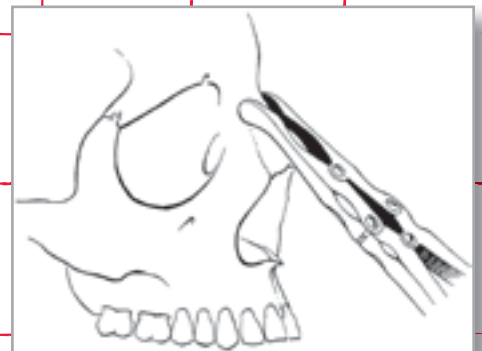



TREVALLi

Stanzen
Rongeurs
Pinzas saca-bocadas
Pinces emporte-pièce
Pinze taglianti

16 cm - 6 1/2"

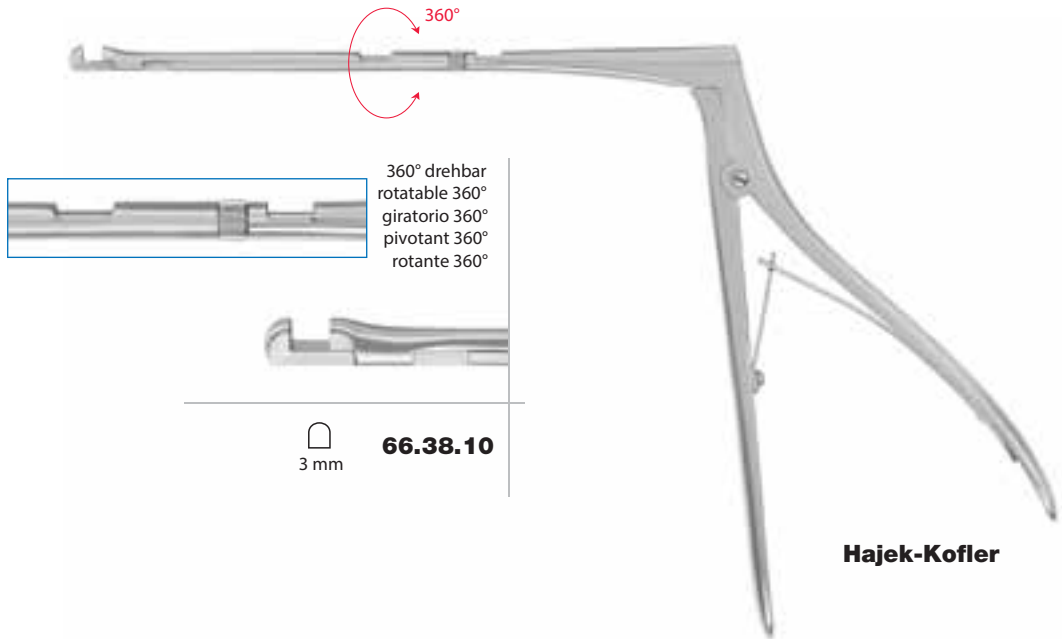

360° drehbar
rotatable 360°
giratorio 360°
pivotant 360°
rotante 360°

3 mm **66.38.10**

Hajek-Kofler

14 cm - 5 1/2"

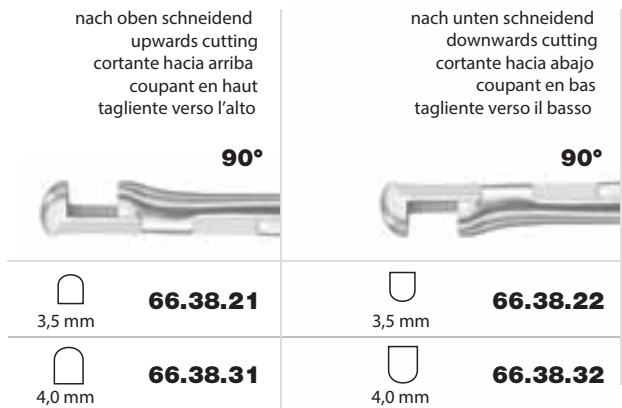

nach oben schneidend
upwards cutting
cortante hacia arriba
coupant en haut
tagliante verso l'alto

90°

3,5 mm **66.38.21**

4,0 mm **66.38.31**

nach unten schneidend
downwards cutting
cortante hacia abajo
coupant en bas
tagliante verso il basso

90°

3,5 mm **66.38.22**

4,0 mm **66.38.32**

Hajek



TREVALLi

Rongeurs
Pinzas saca-bocadas
Pinces emporte-pièce
Pinze taglienti

10 cm - 4"

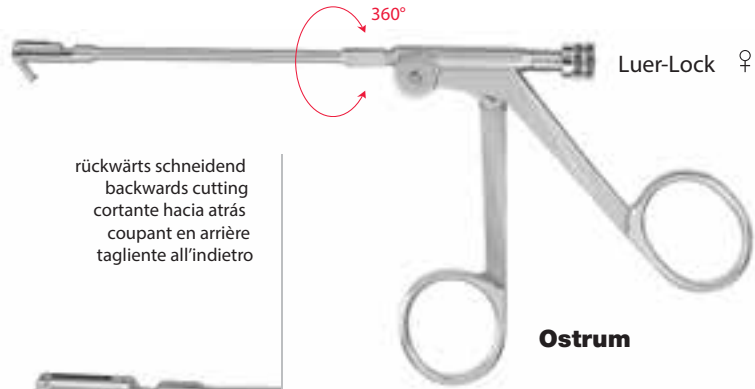

360° drehbar
rotatable 360°
giratorio 360°
pivotant 360°
rotante 360°

rückwärts schneidend
backwards cutting
cortante hacia atrás
coupant en arrière
tagliante all'indietro

Luer-Lock ♀

Ostrum

Schaft
Shaft
Vástago
Tige
Asta



Ø 2,7 mm

1,5 mm  **66.32.58**

Ø 3,5 mm

2,5 mm  **66.32.63**

Schaft
Shaft
Vástago
Tige
Asta

Ø **2,7** mm

Ø **3,5** mm

10 cm - 4"

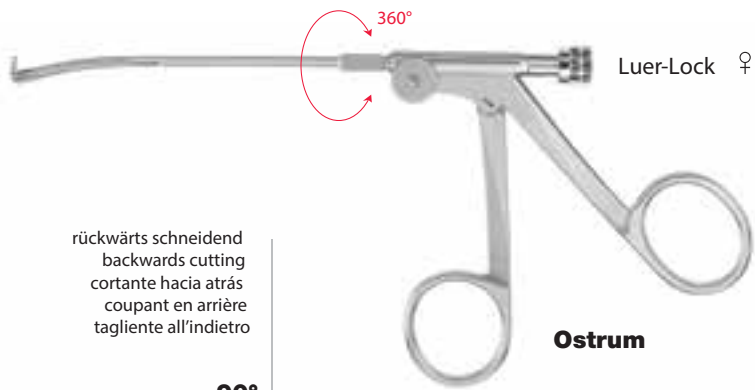

360° drehbar
rotatable 360°
giratorio 360°
pivotant 360°
rotante 360°

rückwärts schneidend
backwards cutting
cortante hacia atrás
coupant en arrière
tagliante all'indietro

Luer-Lock ♀

Ostrum

90°



2,0 mm  **66.32.65**

Schaft
Shaft
Vástago
Tige
Asta

Ø **2,7** mm



TREVALLI

Rongeurs
Pinzas saca-bocadas
Pinces emporte-pièce
Pinze taglienti

Antrumstanzen
Antrum punches
Pinzas saca-bocadas del antro
Pinces emporte-pièce pour l'antre
Pinze taglienti per antro

10 cm - 4"



nach oben rückwärts schneidend
upward cut, backwards
cortante hacia atrás y arriba
coupant en haut en arrière
tagliente verso l'alto e all'indietro



2,5 mm **66.32.51**

nach rechts rückwärts schneidend
right cut, backwards
cortante hacia atrás derecho
coupant en arrière vers la droite
tagliente verso destra e all'indietro



2,5 mm **66.32.52**

nach links rückwärts schneidend
left cut, backwards
cortante hacia atrás izquierdo
coupant en arrière vers la gauche
tagliente verso sinistra e all'indietro



2,5 mm **66.32.53**

Schaft
Shaft
Vástago
Tige
Asta
Ø 3,2 mm

10 cm - 4"

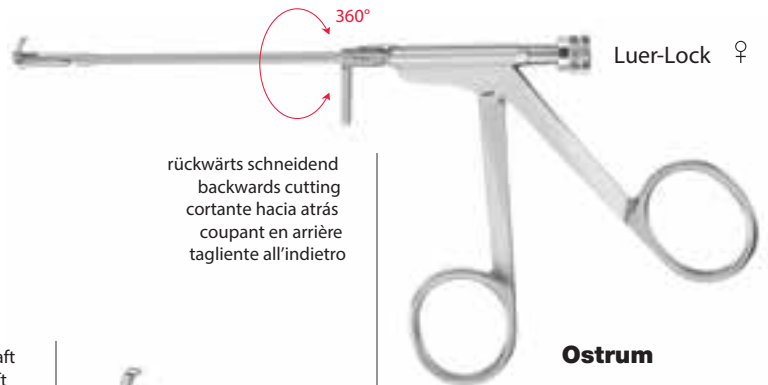

Luer-Lock ♀



360° drehbar
rotatable 360°
giratorio 360°
pivotant 360°
rotante 360°

mit Fingerbewegung
finger movement
con movimiento a dedo
maniable par doigt
con movimento delle dita

rückwärts schneidend
backwards cutting
cortante hacia atrás
coupant en arrière
tagliente all'indietro

Schaft
Shaft
Vástago
Tige
Asta

Ø 2,7 mm 1,5 mm **66.32.59**

Ø 3,5 mm 2,5 mm **66.32.64**

Ostrum

Schaft
Shaft
Vástago
Tige
Asta
Ø 2,7 mm
Ø 3,5 mm



TREVALLi

Rongeurs
Pinzas saca-bocadas
Pinces emporte-pièce
Pinze taglienti

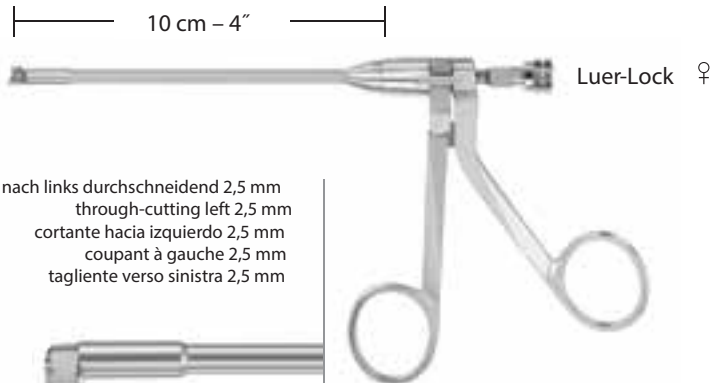

nach rechts durchschneidend 2,5 mm
 through-cutting right 2,5 mm
 cortante hacia derecho 2,5 mm
 coupant à droite 2,5 mm
 tagliente verso destra 2,5 mm



nach links durchschneidend 2,5 mm
 through-cutting left 2,5 mm
 cortante hacia izquierdo 2,5 mm
 coupant à gauche 2,5 mm
 tagliente verso sinistra 2,5 mm



2,5 mm



40°

66.33.00

66.33.01

66.33.06

66.33.07

Schaft
 Shaft
 Vástago
 Tige
 Asta

Ø **2,7** mm

nach rechts durchschneidend 3,5 mm
 through-cutting right 3,5 mm
 cortante hacia derecho 3,5 mm
 coupant à droite 3,5 mm
 tagliente verso destra 3,5 mm



nach links durchschneidend 3,5 mm
 through-cutting left 3,5 mm
 cortante hacia izquierdo 3,5 mm
 coupant à gauche 3,5 mm
 tagliente verso sinistra 3,5 mm



3,5 mm



40°

66.33.03

66.33.04

66.33.09

66.33.10

Schaft
 Shaft
 Vástago
 Tige
 Asta

Ø **4,0** mm



TREVALLi

Rongeurs
Pinzas saca-bocadas
Pinces emporte-pièce
Pinze taglianti

10 cm - 4"



Luer-Lock ♀

nach oben rückwärts schneidend
 upward cut, backwards
 cortante hacia atrás y arriba
 coupant en haut en arrière
 tagliente verso l'alto e all'indietro



nach rechts rückwärts schneidend
 right cut, backwards
 cortante hacia atrás derecho
 coupant en arrière vers la droite
 tagliente verso destra e all'indietro



nach links rückwärts schneidend
 left cut, backwards
 cortante hacia atrás izquierdo
 coupant en arrière vers la gauche
 tagliente verso sinistra e all'indietro



Ostrum

1,5 mm **66.32.55**

1,5 mm **66.32.56**

1,5 mm **66.32.57**

2,5 mm **66.32.60**

2,5 mm **66.32.61**

2,5 mm **66.32.62**

Schaft Shaft Vástago Tige Asta	Ø 2,7 mm
	Ø 3,5 mm

16 cm - 6 1/4"

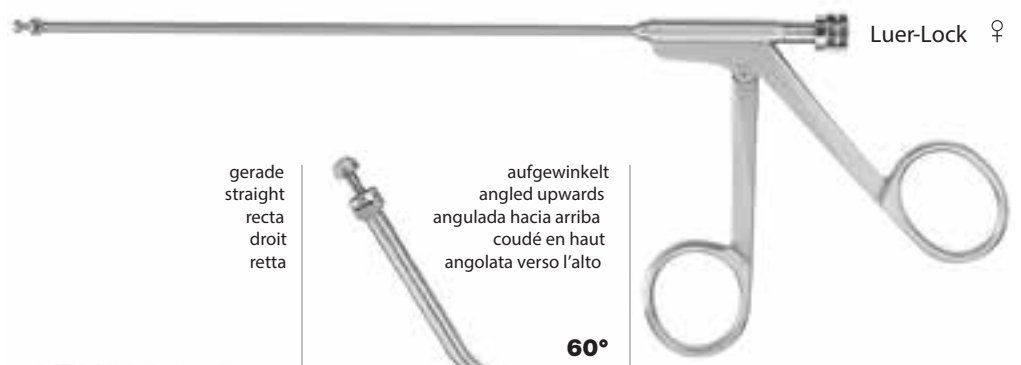

Luer-Lock ♀

gerade
straight
recta
droit
retta



aufgewinkelt
angled upwards
angulada hacia arriba
coudé en haut
angolata verso l'alto

60°



Ø 3,5 mm **66.33.20**

66.33.21

Ø 4,5 mm **66.33.23**

66.33.24

Schaft Shaft Vástago Tige Asta	Ø 2,7 mm
--	-----------------



TREVALLi

Rongeurs
Pinzas saca-bocadas
Pinces emporte-pièce
Pinze taglianti

10 cm - 4"



mit Mandrin
with guide
con mandril
avec mandrin
con mandrino

nach oben rückwärts schneidend
upward cut, backwards
cortante hacia atrás y arriba
coupant en haut en arrière
tagliante verso l'alto e all'indietro



nach rechts rückwärts schneidend
right cut, backwards
cortante hacia atrás derecho
coupant en arrière vers la droite
tagliante verso destra e all'indietro



Ostrum

2,0 mm  **66.32.70**

2,0 mm  **66.32.71**

2,5 mm  **66.32.74**

2,5 mm  **66.32.75**

Schaft
Shaft
Vástago
Tige
Asta

Ø **4,0** mm

Ø **5,0** mm

10 cm - 4"



mit Mandrin
with guide
con mandril
avec mandrin
con mandrino

nach links rückwärts schneidend
left cut, backwards
cortante hacia atrás izquierdo
coupant en arrière vers la gauche
tagliante verso sinistra e all'indietro



nach oben rückwärts schneidend, gebogen
upward cut, backwards, curved
cortante hacia atrás y arriba, curva
coupant en haut en arrière, courbes
tagliante verso l'alto e all'indietro, curva



Ostrum

2,0 mm  **66.32.72**

2,0 mm  **66.32.73**

2,5 mm  **66.32.76**

2,5 mm  **66.32.77**

Schaft
Shaft
Vástago
Tige
Asta

Ø **4,0** mm

Ø **5,0** mm



mit Absaugung
with suction
con aspiración
avec aspiration
con aspirazione



TREVALLi

Gewebe- und Knorpelfasspinzetten
Tissue and Cartilage Forceps
Pinzas para agarrar tejidos y cartilagos
Pinces pour saisir le tissu et cartilage
Pinze per afferrare tessuti e cartilagine

Gewebefasszange
Tissue grasping forceps
Pinza para agarrar tejidos
Pince à saisir les tissus
Pinza per afferrare tessuti



15,5 cm - 6 1/8"

67.58.45

Fox

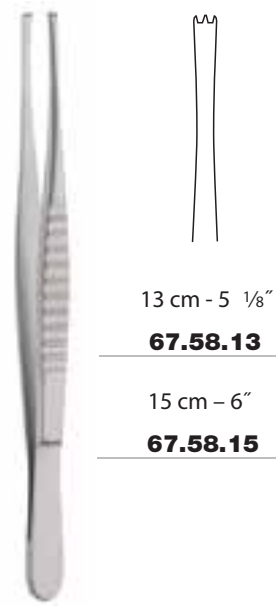

13 cm - 5 1/8"

67.58.13

15 cm - 6"

67.58.15

Fox

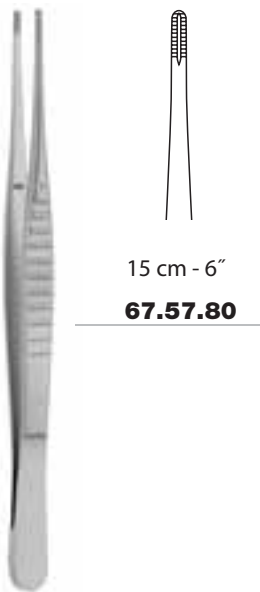

15 cm - 6"

67.57.80

Cottle

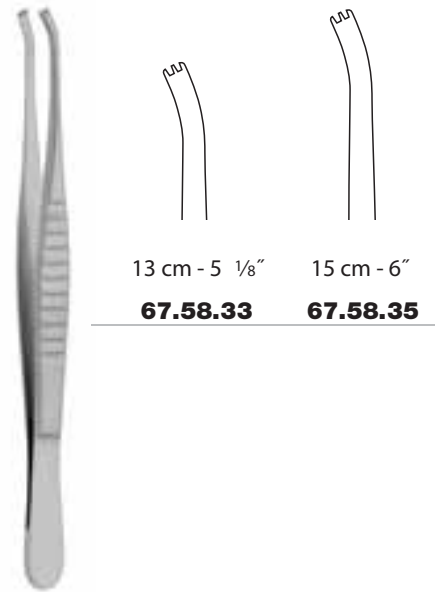

13 cm - 5 1/8"

67.58.33

15 cm - 6"

67.58.35

Fox

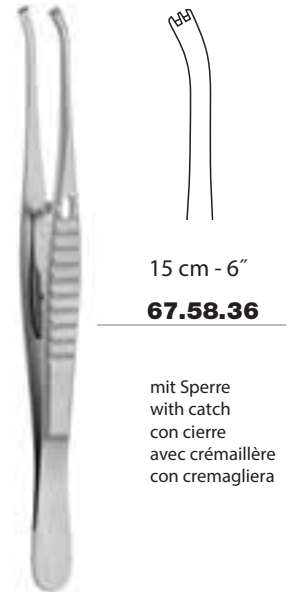

15 cm - 6"

67.58.36

Fox

mit Sperre
with catch
con cierre
avec crémaillère
con cremagliera



TREVALLi

Gewebe- und Knorpelfasspinzetten, Markierungspinzette
Tissue and Cartilage Forceps, Marking forceps
Pinzas para agarrar tejidos y cartilagos, Pinza para marcar
Pinces pour saisir le tissu et cartilage, Pince pour marquage
Pinze per afferrare tessuti e cartilagine, Pinza per marchiatura



13 cm - 5 1/8"

67.58.14

mit Sperre
with catch
con cremallera
avec crémaillère
con cremagliera

Fox



15 cm - 6"

67.58.51

Cottle



13 cm - 5 1/8"

67.58.43

Hinderer



9,5 cm - 3 3/4"

67.58.54

für die plastische Chirurgie
for plastic surgery
para rinoplastica
pour rhinoplastie
per rinoplastica

Alamuti



11 cm - 4 3/8"

67.58.60

Cottle



8,5 cm - 3 3/8"

67.58.70

Masing



Eine Schneide gezahnt
One blade serrated
Una hoja dentada
Une lame dentelée
Una lama dentellata

Columella-Klemmen
Columella forceps
Pinzas para columela
Pinces pour columelle
Pinze per columella



TREVALLI

Messer
Knives
Cuchillos
Couteaux
Coltelli



1

Ballenger

3 mm



19 cm – 7 1/2"

1 66.50.03

4 mm

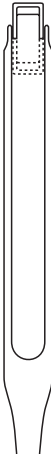

19 cm – 7 1/2"

2 66.50.04

5 mm



19 cm – 7 1/2"

3 66.50.05

6 mm



19 cm – 7 1/2"

4 66.50.06

20 cm – 8"

5 66.50.13

20 cm – 8"

6 66.50.14

20 cm – 8"

7 66.50.15

20 cm – 8"

8 66.50.16



2

Ballenger

Schwingmesser
Swivel knives
Cuchillos para el tabique nasal
Couteaux pour la cloison nasale
Coltelli per setto con lama girevole



Freer



15 cm – 6"

9 66.52.05



Freer



16 cm – 6 1/4"

10 66.52.10

Septummesser
Septum knife
Cuchillo para el tabique nasal
Couteau pour cloison nasale
Coltello per setto nasale



TREVALLi

Messer
Knives
Cuchillos
Couteaux
Coltelli

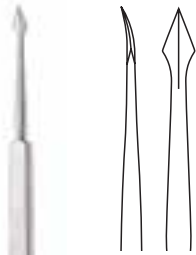

13 cm – 5 1/8"

66.52.20

Knorpelritzmesser
Cartilage knife
Cuchillo para rayar cartilagos
Couteau à cartilage
Coltello per scalfire cartilagine

Masing



66.52.56

Ersatzklinge
Spare blade
Hoja de repuesto
Lame de rechange
Lama di ricambio



16 cm – 6 1/4"

66.52.55

Septummesser, verstellbar
Septum knife, adjustable
Cuchillo para tabique nasale, ajustable
Couteau pour la cloison nasale, ajustable
Coltello per il setto nasale, regolabile

Brünings

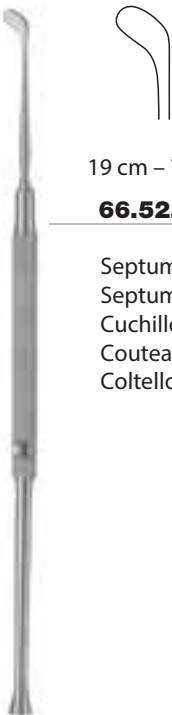

19 cm – 7 1/2"

66.52.60

Septummesser
Septum knife
Cuchillo para el tabique nasal
Couteau pour la cloison nasale
Coltello per il setto nasale

Freer

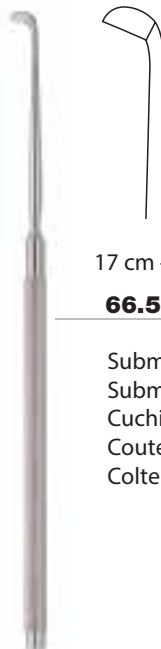

17 cm – 6 3/4"

66.52.70

Submukosamesser
Submucosa knife
Cuchillo para submucosa
Couteau pour submuqueuse
Coltello per submucosa

Freer-Ingals



TREVALLi

**Rhinoplastikmesser
Rhinoplasty Knives
Cuchillos para rinoplastía
Couteaux pour rhinoplastie
Coltelli per rinoplastica**

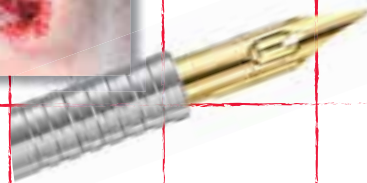

Gubisch

Zur Markierung von Inzisionslinien auf der Haut/Schleimhaut.
For marking incision lines on the skin/mucous membrane.
Para marcar líneas de incisión en la piel/mucosa.
Pour le repérage des traits d'incision sur la peau/la muqueuse.
Per marcare le linee di incisione sulla cute e sulla mucosa.



44.90.72

Feder
Pen
Pluma
Plume
Penna



13 cm - 5 1/8"

44.90.70

Federhalter
Pen holder
Porta-plumas
Porte-plume
Porta-penna

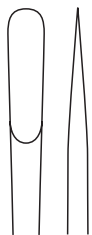

14 cm - 5 1/2"

67.10.20

Septummesser
Septum knife
Cuchillo para el tabique nasal
Couteau pour cloison nasale
Coltello per il setto nasale

Cottle



15 cm - 6"

67.10.30

Joseph



15 cm - 6"

67.10.35

Converse



Verpackungseinheit "X" Stück
Packing unit "X" pieces
Paquete de "X" unidades
Emballage de "X" pièces
Confezione da "X" pezzi



TREVALLI

**Rhinoplastikmesser
Rhinoplasty Knives
Cuchillos para rinoplastía
Couteaux pour rhinoplastie
Coltelli per rinoplastica**



16 cm - 6 1/4"
67.10.60

Joseph

Septum-Knorpelmesser
Septum cartilage knives
Cuchillos para cartilago del tabique nasal
Couteaux à cartilage de la cloison nasale
Coltelli per cartilagine del setto nasale



16 cm - 6 1/4"
67.10.65

Maltz

mit Klingenschutz
with blade guard
con protector de hoja
avec capuchon protecteur
con protettore di lama

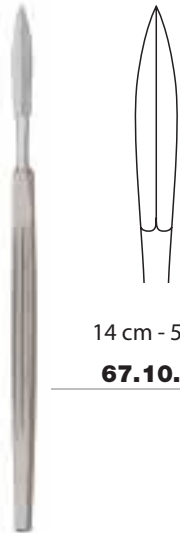

14 cm - 5 1/2"
67.10.40

Cottle

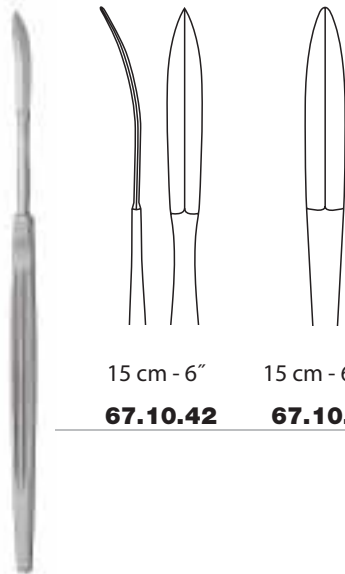

15 cm - 6" 15 cm - 6"
67.10.42 **67.10.43**

Joseph

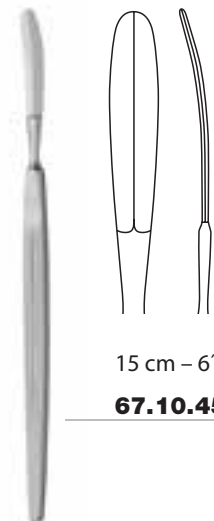

15 cm - 6"
67.10.45

Fomon



TREVALLi

**Dermatome
Dermatomes
Dermatomos
Dermatomes
Dermatomi**



32 cm - 12 1/2"

67.14.30

Humby

Dermatome
Dermatomes
Dermatomos
Dermatomes
Dermatomi

Schnittstärke
Thickness of cut
Grosor del corte
Epaisseur de la coupe
Spessore del taglio

Schnittbreite
Width of cut
Ancho del corte
Largeur de la coupe
Larghezza del taglio

67.14.30

0,1 - 1,2 mm

155 mm (max.)

67.14.35

0,1 - 2,0 mm

155 mm (max.)



30,5 cm - 12"

67.14.35

Watson



15,5 cm - 6 1/8"

67.14.31

Ersatzklinge
Spare blade
Hoja de repuesto
Lame de rechange
Lama di ricambio



TREVALLi

**Dermatome
Dermatomes
Dermatomos
Dermatomes
Dermatomi**



Dermatom mit 2 Spannplatten
Dermatome with 2 stretching plates
Dermatomo con 2 placas tensoras
Dermatome avec 2 plaques à tendre
Dermatomo con 2 piastre per tendere

Schnittstärke Thickness of cut Grosor del corte Epaisseur de la coupe Spessore del taglio	Schnittbreite Width of cut Ancho del corte Largeur de la coupe Larghezza del taglio
0,1 - 2,0 mm	100 mm (max.)

30 cm - 11 3/4"
67.14.50

Schink



13 x 7,5 cm

67.14.52

Haut-Spannplatte
Skin stretching plate
Placa tensora de membrana
Plaques pour tendre la peau
Piastra per tendere la pelle



10 cm - 4"

67.14.51

Ersatzklinge
Spare blade
Hoja de repuesto
Lame de rechange
Lama di ricambio



Dermatom
Dermatome
Dermatomo
Dermatome
Dermatomo

Schnittstärke Thickness of cut Grosor del corte Epaisseur de la coupe Spessore del taglio	Schnittbreite Width of cut Ancho del corte Largeur de la coupe Larghezza del taglio
0,1 - 2,0 mm	40 mm (max.)

19 cm - 7 1/2"

78.05.00

Silver

Ersatzklinge
Spare blade
Hoja de repuesto
Lame de rechange
Lama di ricambio



01.94.19 P₁₀



Verpackungseinheit "X" Stück
Packing unit "X" pieces
Paquete de "X" unidades
Emballage de "X" pièces
Confezione da "X" pezzi



TREVALLi

Nasenflügelhaken
Alar Retractors
Separadores para las alas nasales
Ecarteurs pour les ailes du nez
Divaricatori per alette nasali



Nasenflügelhäkchen
Alar retractors
Ganchos para las alas de la nariz
Crochets pour les ailes du nez
Divaricatori per alette nasali



3 x 4 mm
15 cm - 6"
67.20.03

Cottle

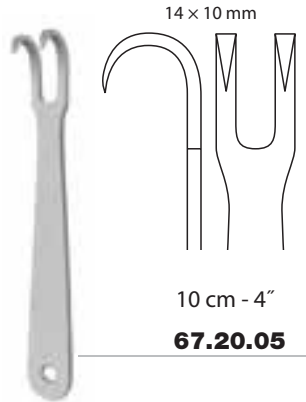

14 x 10 mm
10 cm - 4"
67.20.05

Kilner

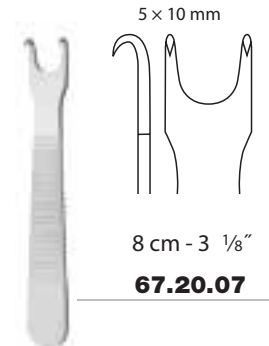

5 x 10 mm
8 cm - 3 1/8"
67.20.07

Gubisch-Kilner

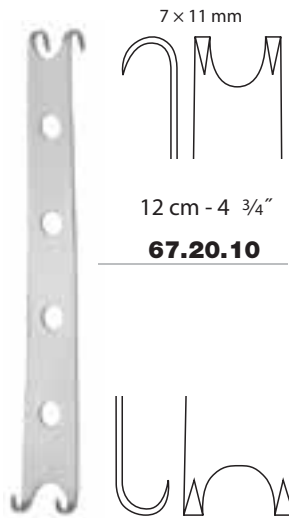

7 x 11 mm
12 cm - 4 3/4"
67.20.10

Converse

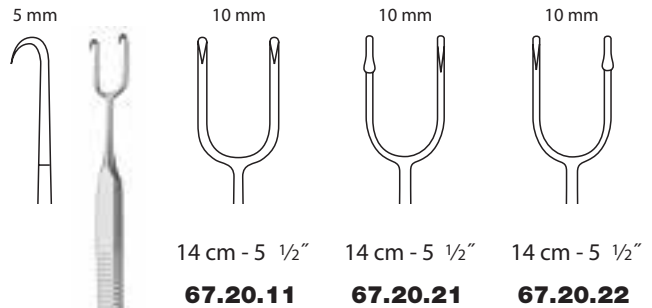

5 mm
10 mm
10 mm
10 mm
14 cm - 5 1/2"
67.20.11 **67.20.21** **67.20.22**

Cottle

Alar- und Hauthäkchen
Alar and skin hooks
Ganchos para las alas de la nariz y la piel
Crochets alaires et dermiques
Uncinetti per alette nasali e pelle



TREVALLi

mit Fingerring
with finger ring
con anillo
avec bague
con anello

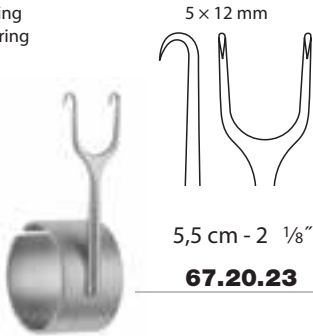

Millard (Cottle)

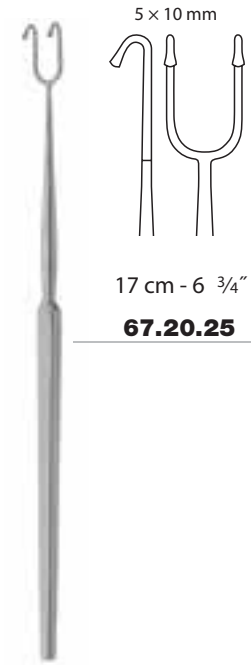

Fomon

**Nasenflügelhaken
Alar Retractors
Separadores para las alas nasales
Ecarteurs pour les ailes du nez
Divaricatori per alette nasali**

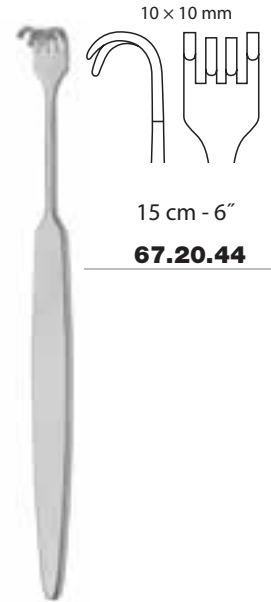

Cottle

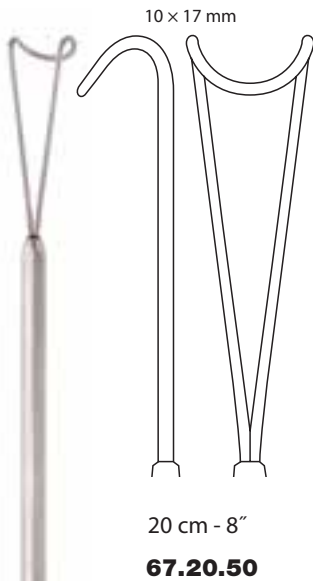

Masing

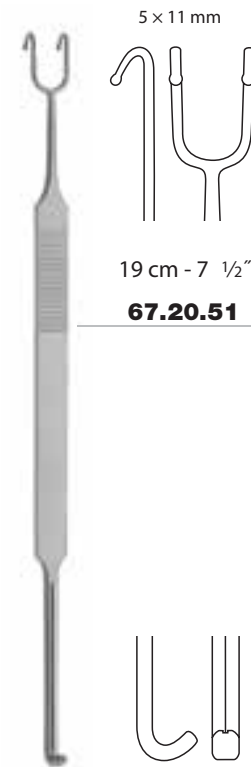

Neivert



Cottle-Neivert

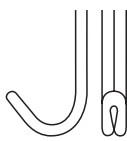

mit Führungsrinne
with guide channel
con estría de guía
avec cannelure
con scanalatura di guida



TREVALLi

**Nasenhaken, Nasenflügelhaken
Nasal Retractors, Alar Retractors
Separadores nasales, Separadores para las alas nasales
Ecarteurs nasaux, Ecarteurs pour les ailes du nez
Divaricatori nasali, Divaricatori per alette nasali**

Nasenflügelhaken
Alar retractors
Separadores para las alas nasales
Ecarteurs pour les ailes du nez
Divaricatori per alette nasali

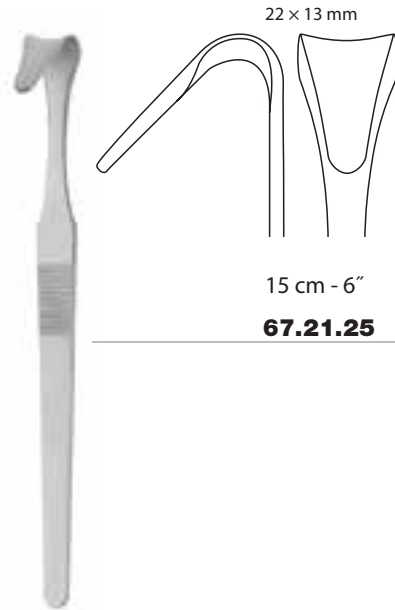

22 x 13 mm

15 cm - 6"

67.21.25

Cottle

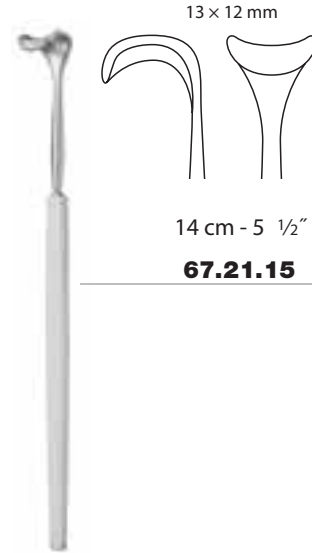

13 x 12 mm

14 cm - 5 1/2"

67.21.15

Cottle

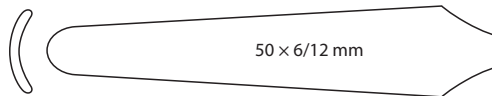

50 x 6/12 mm



17 cm - 6 3/4"

67.21.33

Gubisch-Aufricht

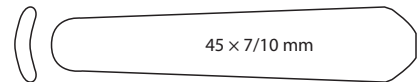

45 x 7/10 mm



18 cm - 7 1/8"

67.21.35

Aufricht



TREVALLi

Nasenhaken
Nasal Retractors
Separadores nasales
Ecarteurs nasaux
Divaricatori nasali

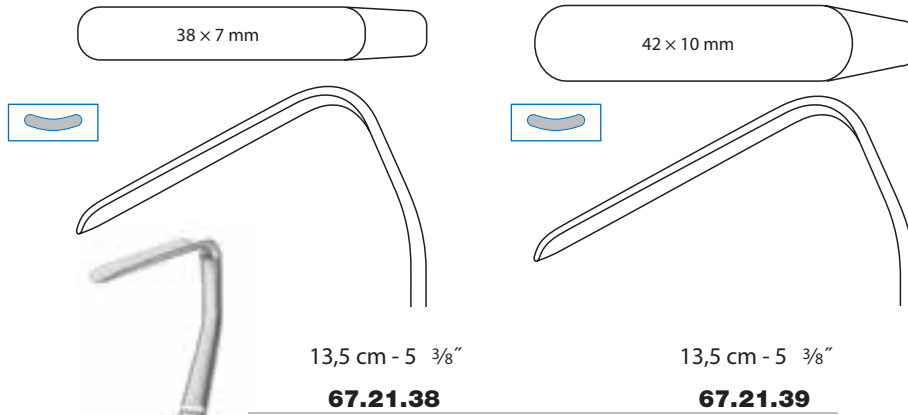

67.21.38

67.21.39

Aufricht

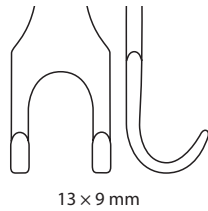

13 x 9 mm

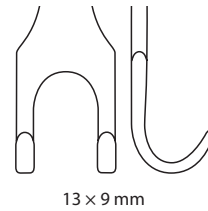

13 x 9 mm

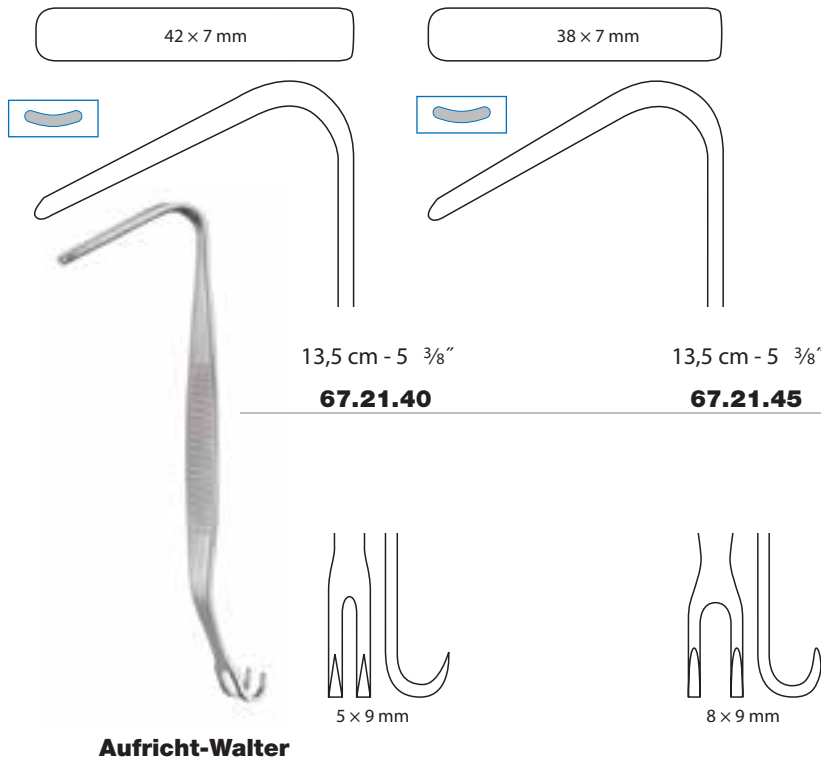

13,5 cm - 5 3/8"

67.21.40

13,5 cm - 5 3/8"

67.21.45

Aufricht-Walter



5 x 9 mm

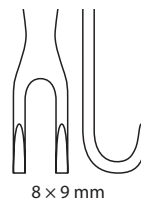

8 x 9 mm

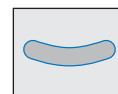

Wundhakenblatt, gewölbt
Retractor blade, curved
Hoja de separador, abovedada
Lame d'ecarteur, courbée
Valva di divaricatore, convessa



TREVALLi

Nasenhaken
Nasal Retractors
Separadores nasals
Ecarteurs nasaux
Divaricatori nasali



18,5 cm - 7 1/4"

67.21.30

Walter

Wundhaken mit Kaltlichtbeleuchtung
Retractor with fibre optic illumination
Separadores con iluminación de luz fría
Ecarteur avec illumination à lumière froide
Divaricatore con illuminazione a luce fredda

inklusive Adapter zum Anschluß für Lichtleitkabel
including adapter for connection to fibre optic cable
incluyendo el adaptador para la conexión con cable fibra óptica
avec adaptateur pour brancher le câble conducteur de lumière en fibres de verre
compreso l'adattatore per la connessione di cavi a luce fredda

MEDICON/STORZ · WOLF · ACMI



TREVALLi



Septum-Elevatorien
Septum Elevators
Elevadores para el tabique nasal
Élévateurs pour la cloison nasale
Elevatori per il setto nasale

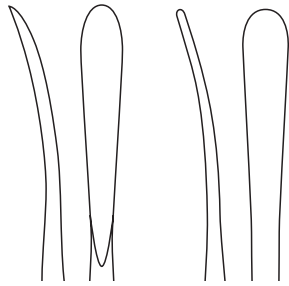

19 cm - 7 1/2"

66.53.01

19 cm - 7 1/2"

66.53.02



Freer



18 cm - 7 1/8"

66.54.10



Killian

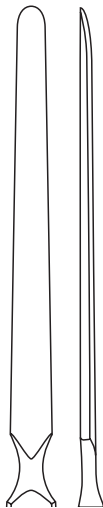

17 cm - 6 3/4"

66.53.11

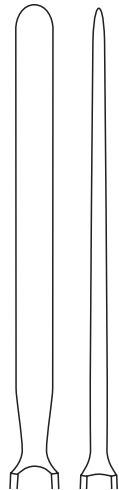

17 cm - 6 3/4"

66.53.12



Killian



scharf
sharp
aguda
pointu
acuta

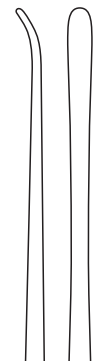

17 cm - 6 3/4"

66.53.32



stumpf
blunt
roma
mousse
smussa

Halle



TREVALLi

Septum-Elevatorien
Septum Elevators
Elevadores para el tabique nasal
Elévateurs pour la cloison nasale
Elevatori per il setto nasale

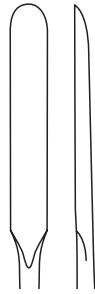

23 cm - 9"

66.54.15

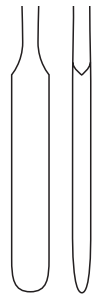

Killian



5 mm



19 cm - 7 1/2"

26.35.01



5 mm

5 mm



19 cm - 7 1/2"

26.35.02



5 mm

6,5 mm



19 cm - 7 1/2"

26.35.03



6,5 mm

Freer

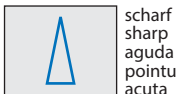

scharf
sharp
aguda
pointu
acuta



stumpf
blunt
roma
mousse
smussa



TREVALLi

Septum-Elevatorien
Septum Elevators
Elevadores para el tabique nasal
Élévateurs pour la cloison nasale
Elevatori per il setto nasale

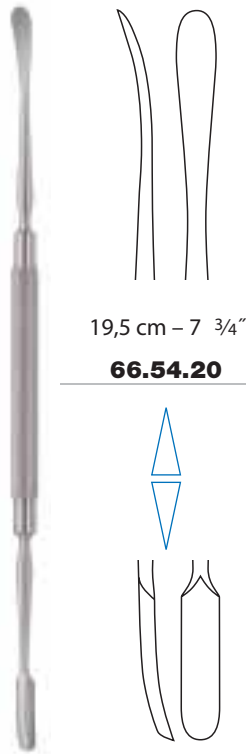

19,5 cm – 7 3/4"

66.54.20

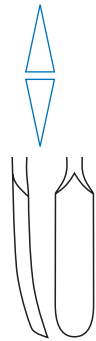

Freer-Joseph



20 cm – 8"

66.54.30

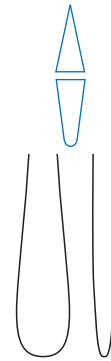

Hajek-Ballenger



scharf
sharp
aguda
pointu
acuta



stumpf
blunt
roma
mousse
smussa



TREVALLi

Septum-Elevatorien
Septum Elevators
Elevadores para el tabique nasal
Elévateurs pour la cloison nasale
Elevatori per il setto nasale



21,5 cm – 8 1/2"

66.54.40

Howarth



20 cm – 8"

66.54.50

Pennington



20 cm – 8"

66.54.55

Pierce



TREVALLi

Sinuslifting Elevatorien
Sinuslifting Elevators
Elevadores para sinus-lift
Elévateurs pour sinus-lift
Elevatori per sinus-lifting

3 mm

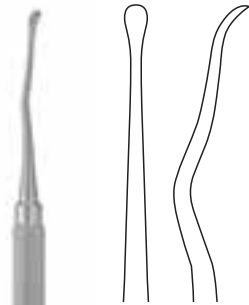

20,5 cm – 8"

68.82.49

3 mm

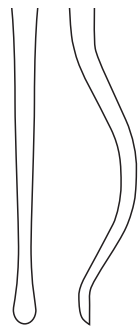

4 mm

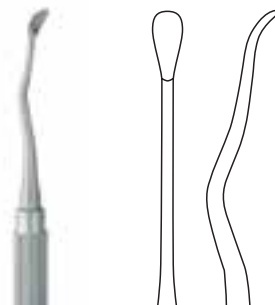

20,5 cm – 8"

68.82.50

4 mm



6 mm

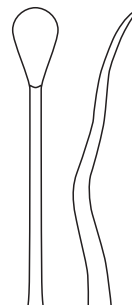

20,5 cm – 8"

68.82.51

6 mm

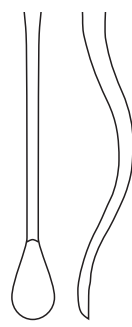



TREVALLi

**Elevatorien, Raspatorien
Elevators, Raspatories
Elevadores, Legras
Elévateurs, Rugines
Elevatori, Periostotomi**



20 cm – 8"

66.59.70

Raspatorium
Raspatory
Legra
Rugine
Periostotomo

Sewall

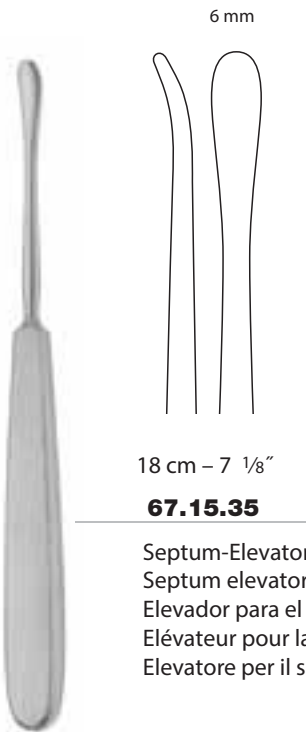

18 cm – 7 1/8"

67.15.35

Septum-Elevatorium
Septum elevator
Elevador para el tabique nasal
Elévateur pour la cloison nasale
Elevatore per il setto nasale

Yankauer

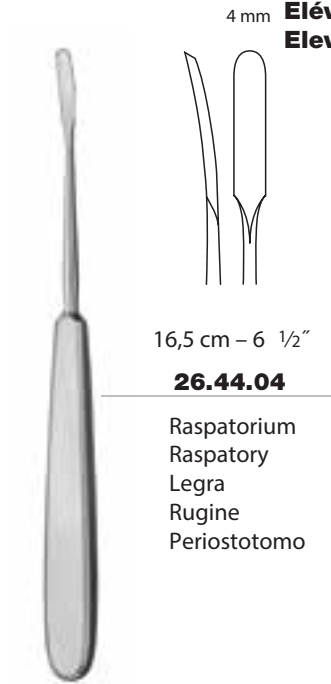

16,5 cm – 6 1/2"

26.44.04

Raspatorium
Raspatory
Legra
Rugine
Periostotomo

Joseph



22 cm – 8 3/4"

67.15.48

Septum-Raspatorium
Septum raspatory
Legra para el tabique nasal
Rugine pour la cloison nasale
Periostotomo per il setto nasale

Joseph-Masing



TREVALLI



**Elevatorien, Raspatorien
Elevators, Raspatories
Elevadores, Legras
Elévateurs, Rugines
Elevatori, Periostotomi**



Cottle

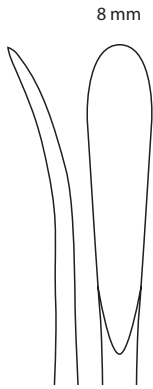

18 cm - 7 1/8"

67.15.50

Raspatorium
Raspatory
Legra
Rugine
Periostotomo

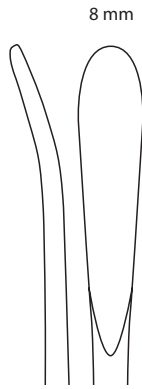

18 cm - 7 1/8"

67.15.51

Elevatorium
Elevator
Elevador
Elévateur
Elevatore



Converse



18 cm - 7 1/8"

67.15.65

Raspatorium
Raspatory
Legra
Rugine
Periostotomo



Boies

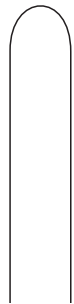

19 cm - 7 1/2"

67.15.70

Nasenfraktur-Elevatorium
Nasal fracture elevator
Elevador para fracturas nasales
Elévateur pour fractures nasales
Elevatore per fratture nasali



TREVALLi



Goldman

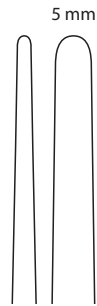

20 cm - 8"

67.15.75

Septumfraktur-Elevatorium
Elevator for fracture of septum
Elevador para fracturas del tabique nasal
Elévateur pour fractures de la cloison nasale
Elevatore per fratture del setto nasale

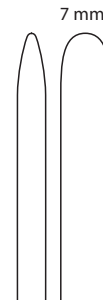

17 cm - 6 3/4"

67.15.80

Reposition von Nasenbeinbrüchen
Repositioning of nasal bone fractures
Reposición de fracturas del hueso nasal
Réposition de fractures de l'os nasal
Riposizione di fratture dell'osso nasale

**Elevatorien, Raspatorien
Elevators, Raspatories
Elevadores, Legras
Elévateurs, Rugines
Elevatori, Periostotomi**



4 mm



21 cm - 8 1/4"

67.15.91

Saugelevatorium
Suction elevator
Elevador para aspiración
Elévateur aspirateur
Elevatore d'aspirazione

mit Mandrin
with guide
con mandril
avec mandrin
con mandrino



TREVALLi

Saugraspatorien
 Suction raspatories
 Legras aspiradoras
 Rugines aspirantes
 Periototomi d'aspirazione

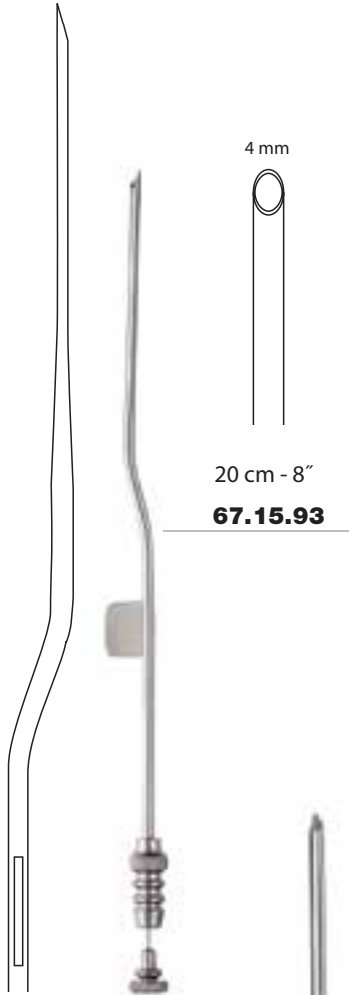

20 cm - 8"
67.15.93

mit Mandrin
 with guide
 con mandril
 avec mandrin
 con mandrino



15 cm - 6"
67.15.96

Saugelevatorium
 Suction elevator
 Elevador aspirador
 Elévateur aspireur
 Elevatore con aspirazione

**Elevatorien, Raspatorien
 Elevators, Raspatories
 Elevadores, Legras
 Elévateurs, Rugines
 Elevatori, Periototomi**



18,5 cm - 7 1/4"
67.15.98

Schlauchansatz, drehbar
 Tube connection, rotatable
 Empalme de tubo, giratorio
 Embout de tuyau, rotatif
 Attacco per tubo, girevole

Haraldsson



TREVALLi

**Elevatorien, Raspatorien
Elevators, Raspatories
Elevadores, Legras
Elévateurs, Rugines
Elevatori, Periototomi**

Septum-Elevatorien
Septum elevators
Elevadores para el tabique nasal
Elévateurs pour cloison nasale
Elevatori per il setto nasale

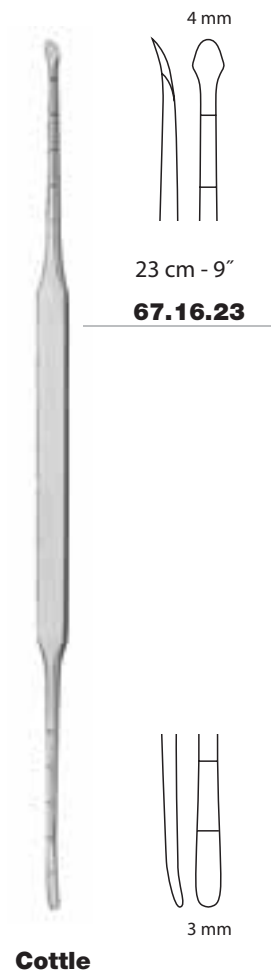



TREVALLi

Raspatorien
Raspatories
Legras
Rugines
Periostotomi

Periost-Kamm
Periosteum comb
Cresta para periostio
Peigne pour périoste
Pettine per periostio

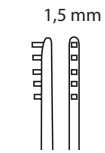

23 cm - 6"

67.16.43

Periost-Feile
Periosteum file
Lima para periostio
Lime pour périoste
Lima per periostio

Cottle

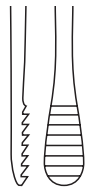

5 mm

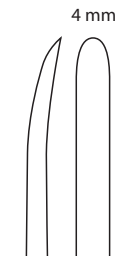

4 mm

22 cm - 8 3/4"

67.16.55

Cottle-McKenty

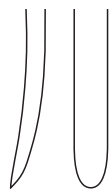

4 mm

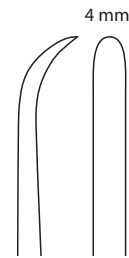

4 mm

22 cm - 8 3/4"

67.16.65

Cottle

Tunnellier-Raspatorium
Tunnelling raspatory
Legra tunelizadora
Rugine à tunnellation
Periostotomo scollatore

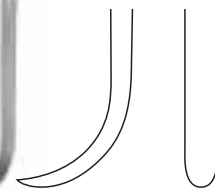

4 mm



TREVALLI

Knorpelquetschen
Cartilage crushers
Trituradora de sustancia cartilaginosa
Presses pour matière cartilagineuse
Trita cartilagine

65 x 30 x 30 mm



67.19.70

Cottle



mit Entnahmeklammer
with clamp for taking out the prepared material
con grapa de toma para sacar el material triturado
avec pince pour enlever la matière pressée
con pinza per prendere il materiale tritato



Durch adaptierten Druck entsteht ein flaches, flexibles Knorpelfließ welches vielfältig einsetzbar ist.

Due to an adapted pressure a flat, flexible cartilage transplant is obtained, which can be applied in various manners.

Mediante una presión adaptada se crea un tejido de cartílago plano y flexible el cual puede ser empleado de diversas maneras.

Une pression adaptée permet de créer un ruisseau de cartilage plan et flexible qui peut être posé variablement.

Mediante una pressione adatta si crea un tessuto di cartilagine piano e flessibile, il quale può essere utilizzato in modi diversi.



65 x 30 mm

67.19.80

Gubisch

Knorpelschneidblock aus Teflon
Cartilage cutting block made of teflon
Bloque de teflon para cortar cartílago
Bloc en teflon pour couper le cartilage
Blocco in teflon per tagliare cartilagine



87 x 55 x 12 mm

67.19.75



TREVALLI

**Sonden
Probes
Estiletos
Stylets
Specilli**

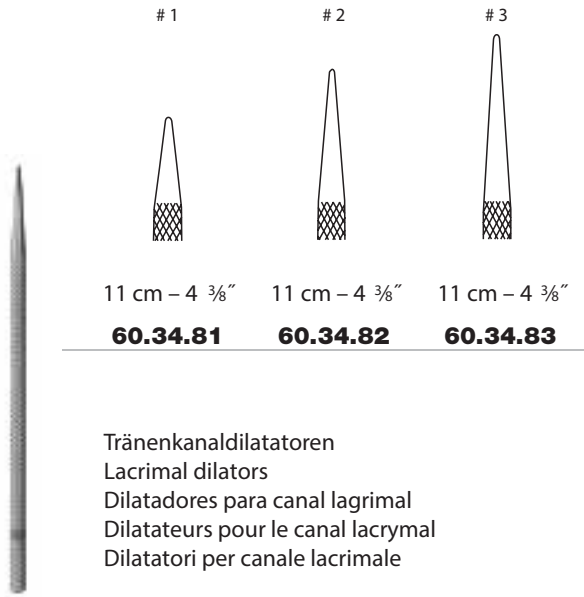

11 cm - 4 3/8"

60.34.81

11 cm - 4 3/8"

60.34.82

11 cm - 4 3/8"

60.34.83

Tränenkanaldilatatoren
Lacrimal dilators
Dilatadores para canal lagrimal
Dilatateurs pour le canal lacrymal
Dilatatori per canale lacrimale

60.34.80

Satz komplett (# 1-3)
Set complete (# 1-3)
Juego completo (# 1-3)
Jeu complet (# 1-3)
Serie completa (# 1-3)

Wilder

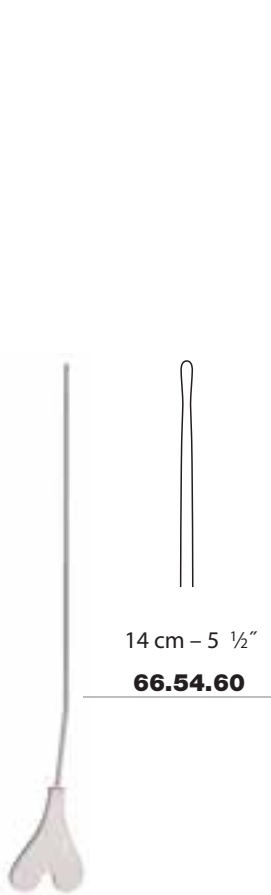

14 cm - 5 1/2"

66.54.60



23 cm - 9"

66.54.95

Choanahaken
Choana hook
Gancho para coanas
Crochet choanal
Uncino per coane

Lange



TREVALLI

**Sonden
Probes
Estiletos
Stylets
Specilli**



Ø 2,0 mm

19 cm – 7 1/2"

66.54.80

Ø 1,2 mm

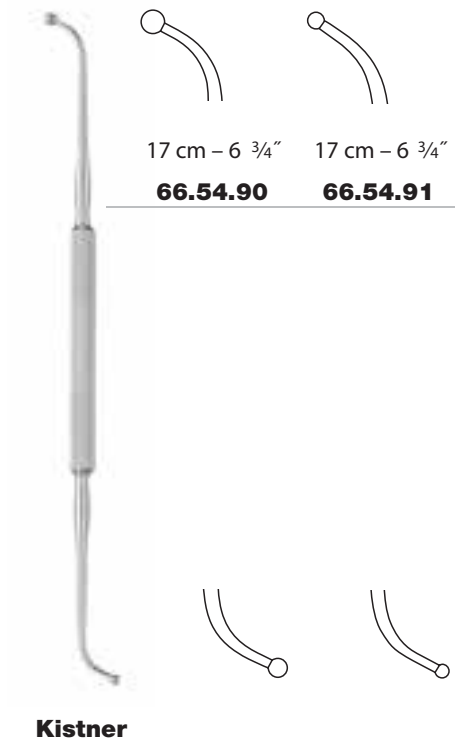

17 cm – 6 3/4"

17 cm – 6 3/4"

66.54.90

66.54.91

Kistner

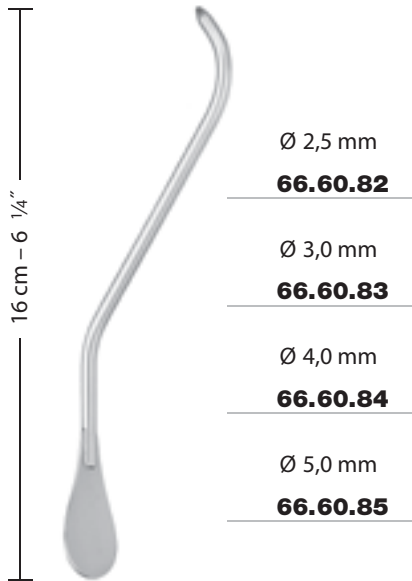

16 cm – 6 1/4"

Ø 2,5 mm

66.60.82

Ø 3,0 mm

66.60.83

Ø 4,0 mm

66.60.84

Ø 5,0 mm

66.60.85

Ritter-Halle

Stirnhöhlendilatatore
Sinus dilators
Dilatadores para el seno
Sondes à sinus
Sonde per il seno



TREVALLi

Raspeln, Knorpelschaber
Rasps, Cartilage abraders
Escofinas, Rascadores de cartilago
Râpes, Grattoirs à cartilages
Raspe, Raschiatore per cartilagine



Wiener

Ø 3,5 mm

Ø 3,5 mm



1:1

18 cm - 7 1/8"

66.62.33



1:1

18 cm - 7 1/8"

66.62.35

Antrumraspeln
 Antrum rasps
 Escofinas para el antro
 Râpes pour l'antre
 Raspe per antro



Watson-Williams

23 cm - 9"

66.62.38

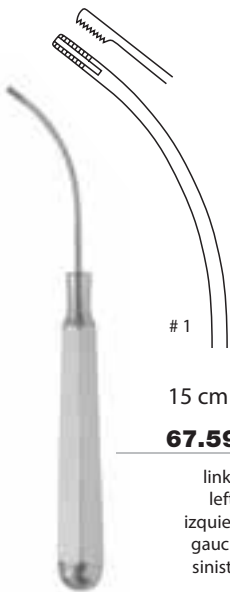

Dingman

1

15 cm - 6"

67.59.11

links
 left
 izquierda
 gauche
 sinistra



2

15 cm - 6"

67.59.12

rechts
 right
 derecha
 droite
 destra

Knorpelschaber
 Cartilage abraders
 Rascadores de cartilago
 Grattoirs à cartilage
 Raschiatore per cartilagine

67.59.10

Satz komplett (# 1+2)

Set complete (# 1+2)

Juego completo (# 1+2)

Jeu complet (# 1+2)

Set completo (# 1+2)



TREVALLI

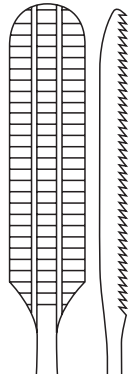

18,5 cm - 7 1/4"

67.59.25

Maltz

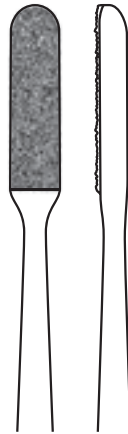

19 cm - 7 1/2"

67.59.26

Diamantbeschichtung
diamond dust coated
diamantado
diamantée
diamantati

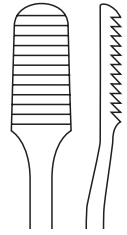

20 cm - 8"

67.59.30

Lewis

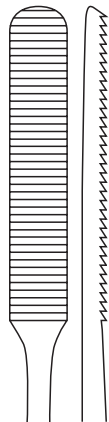

21 cm - 8 1/4"

67.59.35

Cottle

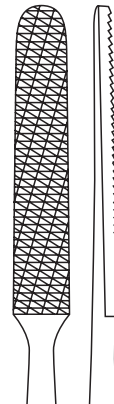

20,5 cm - 8"

67.59.36

Cottle "HM"

"HM"

Hartmetall
Tungsten carbide
Carburo de tungsteno
Carbure de tungstène
Carburo di tungsteno

**Nasenraspeln
Nasal Rasps
Raspadores nasales
Râpes nasales
Raspe nasali**



TREVALLi

**Nasenraspeln
Nasal Rasps
Raspadores nasales
Râpes nasales
Raspe nasali**

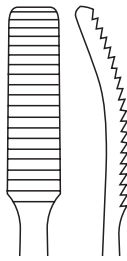

19,5 cm - 7 3/4"

67.59.47

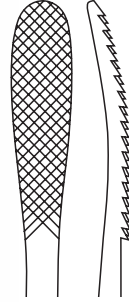

21 cm - 8 1/4"

67.59.40

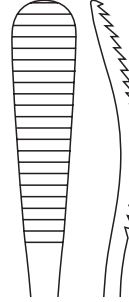

21 cm - 8 1/4"

67.59.41

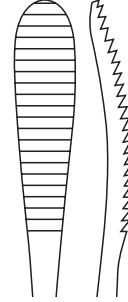

21 cm - 8 1/4"

67.59.42

Aufricht

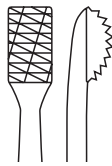

19,5 cm - 7 3/4"

67.59.50

Lewis "HM"

"HM"

Hartmetall
Tungsten carbide
Carburo de tungsteno
Carbure de tungstène
Carburo di tungsteno

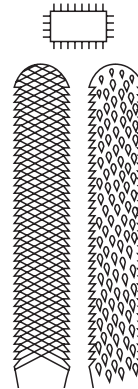

22 cm - 8 3/4"

67.59.60

Fomon





TREVALLi

Nasenfeilen, Nasenraspel
Nasal Files, Nasal Rasp
Limas nasales, Raspador nasal
Limes nasales, Râpe nasale
Lime nasali, Raspa nasale

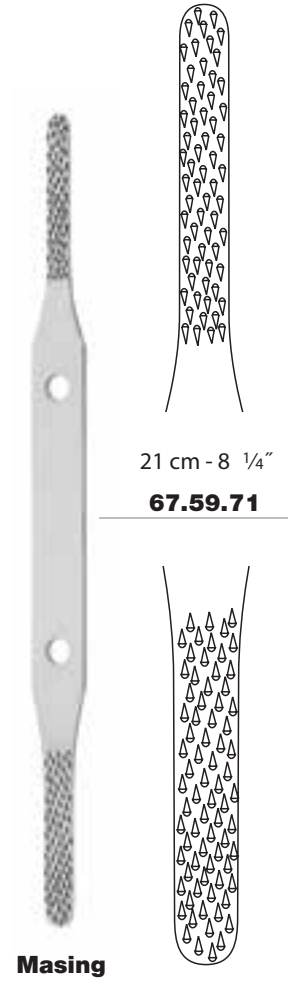
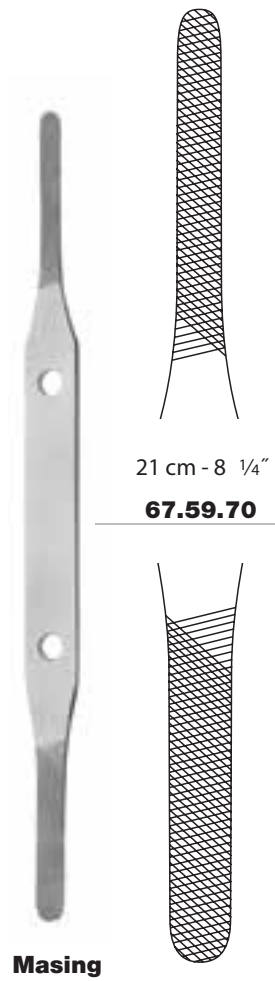
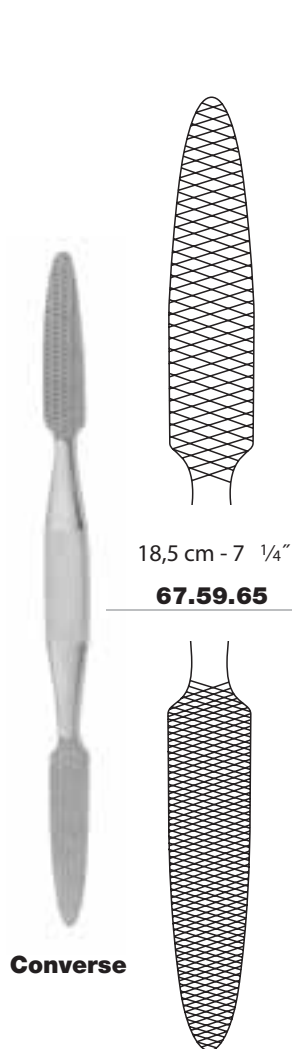

Nasenraspel
Nasal rasp
Raspador nasal
Râpe nasale
Raspa nasale



TREVALLi

Nasenraspeln
Nasal Rasps
Raspadores nasales
Râpes nasales
Raspe nasali

Jeweils ein Arbeitsende der Raspeln arbeitet auf Schub, das andere auf Zug.

One working end of the rasp operates by pushing, the other by pulling.

Una parte de las raspas trabaja a empuje, la otra parte a tracción.

Un bout des râpes coupe en poussant, l'autre en tirant.

Una parte lavorativa della raspa funziona da spinta e l'altra da trazione.



Obwegeser

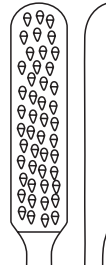

19,5 cm - 7 3/4"

F 67.60.51

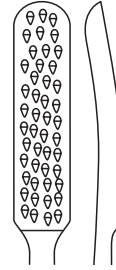

19,5 cm - 7 3/4"

67.60.53

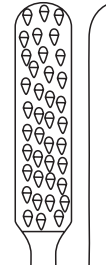

19,5 cm - 7 3/4"

HF 67.60.52

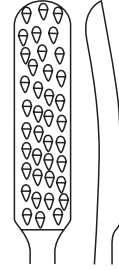

19,5 cm - 7 3/4"

67.60.54

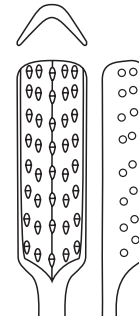

19,5 cm - 7 3/4"

F 67.60.55

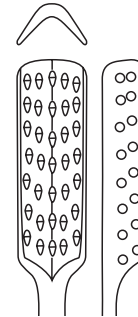

19,5 cm - 7 3/4"

HF 67.60.56



Obwegeser

Die Knochenspäne werden durch die Perforationen nach außen abgedrängt, wodurch die Raspeln nicht verstopfen und einfacher zu reinigen sind.

Bone splinters are pushed through the perforated working ends. This avoids plugging of the rasps and they can be cleaned easily.

Las raspaduras de huesos son apartadas por las perforaciones hacia fuera; así no se atascan los raspadores y pueden ser limpiados más fácil.

Les copeaux d'os sont poussés vers l'extérieur à travers les perforations, ceci évite un bouchage et facilite un meilleur nettoyage.

I trucioli delle ossa verranno eliminati fuori dalla perforazione poichè le raspe non si otturano e sono facilmente pulibili.

F
fein
fine
fino
fine
fine

HF
halbfein
semi fine
semifino
semifin
semifina



TREVALLi

Nasenraspeln
Nasal Rasps
Raspadores nasales
Râpes nasales
Raspe nasali



Fomon "HM"



20 cm - 8"
67.60.60

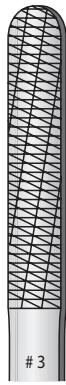

20 cm - 8"
67.60.61



20 cm - 8"
67.60.62



20 cm - 8"
67.60.63



20 cm - 8"
67.60.64



Gubisch-Fomon "HM"



20 cm - 8"
67.60.65



"HM"
Hartmetall
Tungsten carbide
Carburo de tungsteno
Carbure de tungstène
Carburo di tungsteno



TREVALLi

Nasenraspeln
Nasal Rasps
Raspadores nasales
Râpes nasales
Raspe nasali

"X-CHANGE" NASAL RASPS



Die sehr flachen Raspelblätter sind einzeln ersetzbar und gewährleisten auf effiziente Weise immer ein scharfes Instrument.

The very flat, individually replaceable rasp blades are an efficient way of always ensuring a sharp instrument.

Las hojas de la raspa muy planas pueden ser utilizadas por separado y garantizan de forma eficaz que uno dispone siempre de un instrumento adecuadamente afilado.

Les lames de râpes sont interchangeables et disponibles à l'unité. Ce qui assure à l'instrument un parfait tranchant.

Gli inserti di raspa molto fine sono sostituibili singolarmente e garantiscono in modo efficace uno strumento sempre tagliente.

Handgriffe
Handles
Mangos
Manches
Manici



14 cm - 5 1/2" 15 cm - 6"
67.61.00 **67.61.01**

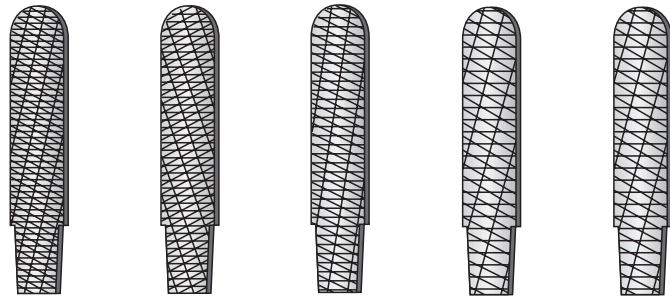

1:1

"HM"

1 # 2 # 3 # 4 # 5
67.61.10 **67.61.11** **67.61.12** **67.61.13** **67.61.14**

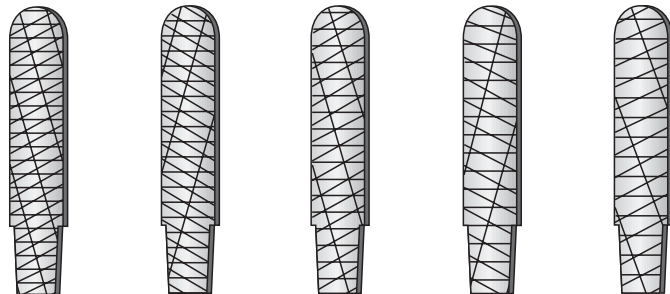

1:1

"HM"

6 # 7 # 8 # 9 # 10
67.61.15 **67.61.16** **67.61.17** **67.61.18** **67.61.19**



Schlüssel
Wrench
Llave
Clé
Chiave



67.61.03

"HM"

Hartmetall
Tungsten carbide
Carburo de tungsteno
Carbure de tungstène
Carburo di tungsteno



TREVALLi

**Nasensägen
Nasal Saws
Sierras nasales
Scies nasales
Seghe nasali**



18,5 cm - 7 1/4"
67.60.10

Joseph



18,5 cm - 7 1/4" 18,5 cm - 7 1/4"
67.60.11 **67.60.12**

Joseph

links
left
izquierda
gauche
sinistra

rechts
right
derecha
droite
destra



15 cm - 6"
67.60.90

Joseph

Sägeschutzführung
Guided guard for nasal saw
Conductor protector para sierra
Guidage protecteur pour scies
Protettore guidasega

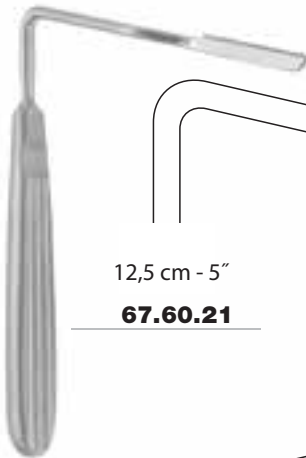

12,5 cm - 5"
67.60.21

Joseph

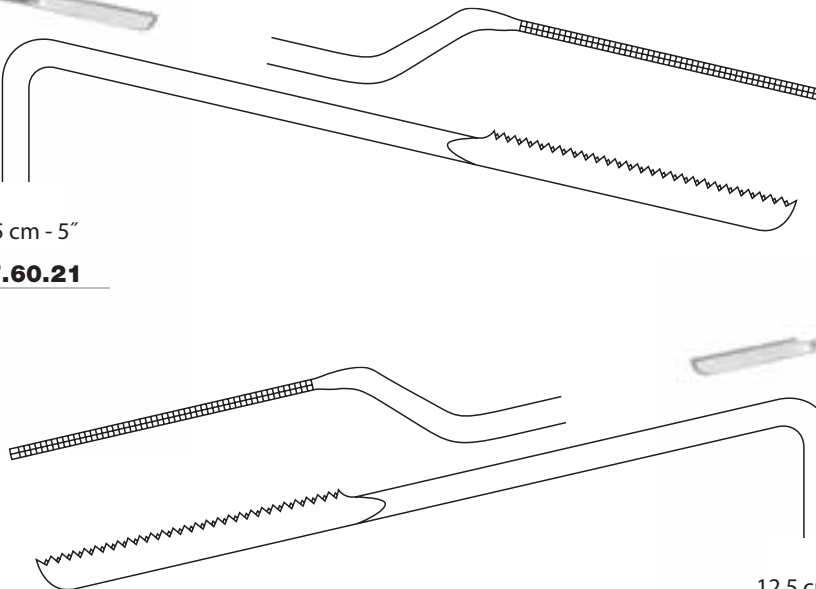

12,5 cm - 5"
67.60.22

Joseph



TREVALLi

Küretten
Curettes
Curetas
Curettes
Curette

Antrumküretten
Antrum curettes
Curetas para antro
Curettes pour antre
Curette per antro



21,5 cm – 8 1/2"

66.58.20

Faulkner



19 cm – 7 1/2"

66.58.80



TREVALLi

**Küretten
Curettes
Curetas
Curettes
Curette**

Antrumküretten
Antrum curettes
Curetas para antro
Curettes pour antre
Curette per antro



1:1

Coakley

1



17 cm - 6 3/4"

66.58.01

2



17 cm - 6 3/4"

66.58.02

3



17 cm - 6 3/4"

66.58.03

4



17 cm - 6 3/4"

66.58.04

5



17 cm - 6 3/4"

66.58.05

6



17 cm - 6 3/4"

66.58.06

66.58.00

- Satz komplett (# 1-6)
- Set complete (# 1-6)
- Juego completo (# 1-6)
- Jeu complet (# 1-6)
- Set completo (# 1-6)



TREVALLi

Küretten
Curettes
Curetas
Curettes
Curette

Antrumküretten
Antrum curettes
Curetas para antro
Curettes pour antre
Curette per antro

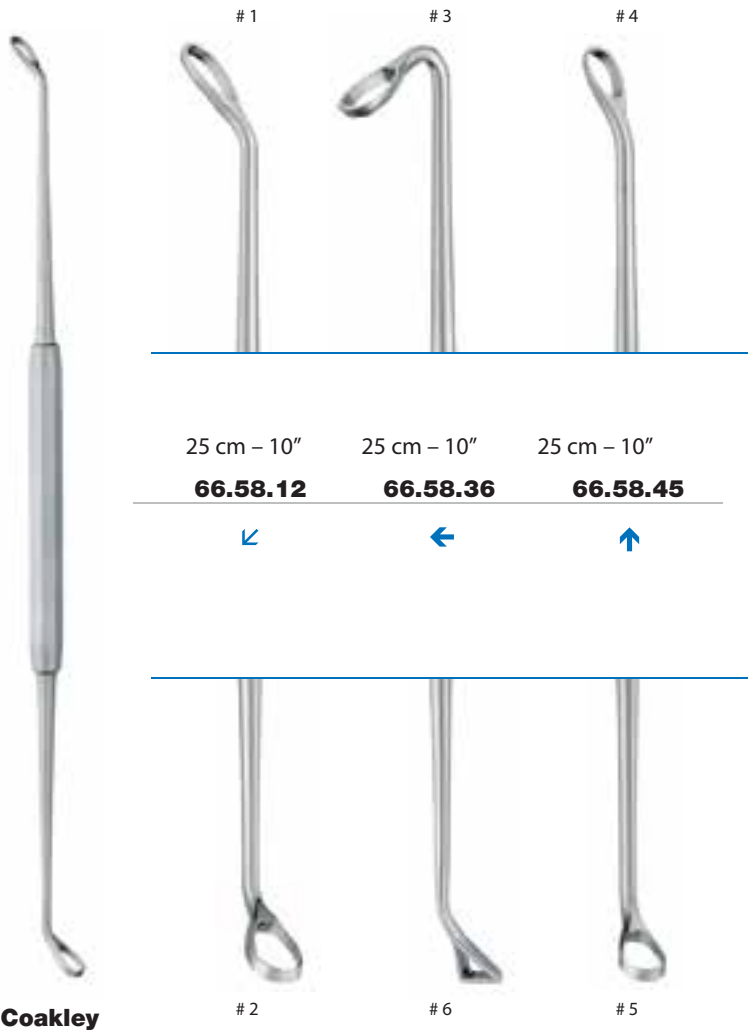



66.58.10
Satz komplett ↙
Set complete ↙
Juego completo ←
Jeu complet ←
Set completo ↑



**Löffel
Curettes
Cucharillas
Curettes
Cucchiai**

	5 mm	3 x 6 mm	3 x 5 mm		55°	90°
						
	20 cm - 8"	20 cm - 8"			19 cm - 7 1/2"	19 cm - 7 1/2"
	66.58.87	66.58.88			66.58.92	66.58.94

Antrumlöffel
Antrum curettes
Cucharillas para antro
Curettes pour antre
Cucchiai per antro

Frontal Sinusküretten
Frontal sinus curettes
Curetas para seno frontal
Curettes pour sinus frontal
Curette per seno frontale

	# 00	# 0
		
	20 cm - 8"	20 cm - 8"
	29.68.42	29.68.50

# 1	# 2
	
20 cm - 8"	20 cm - 8"
29.68.51	29.68.52

Daubenspeck



TREVALLi

**Hämmer
Mallets
Martillos
Maillets
Martelli**

mit Kunststoffbacken
(abschraubbar)

with plastic facings
(unscrewable)

con frentes de plástico
(destornillables)

avec joues en matière plastique
(dévissables)

con guancie di plastica
(svitabili)

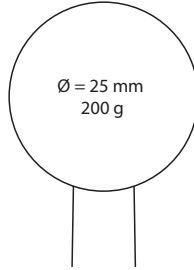

18,5 cm - 7 1/4"

27.06.20

27.06.21

Ersatzbacken zu 27.06.20, Paar
Spare facings for 27.06.20, pair
Frentes de repuesto para 27.06.20, par
Joues de rechange pour 27.06.20, paire
Guancie di ricambio per 27.06.20, paio

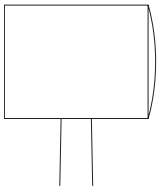

Die gewölbte Seite ist für die
Knorpelquetsche (67.19.70)

→ siehe Seite 376

The round face is used for the
cartilage crusher (67.19.70)

→ see page 376

La cara convexa se usa para
la triturada sustancia
cartilaginosa (67.19.70)

→ véase página 376

La face convexe s'emploie
pour presser la matière
cartilagineuse (67.19.70)

→ voir page 376

La faccia convessa si usa per
la trita cartilagine (67.19.70)

→ vedi pagina 376

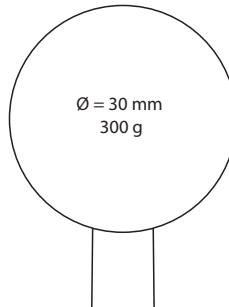

19 cm - 7 1/2"

67.40.20

Cottle

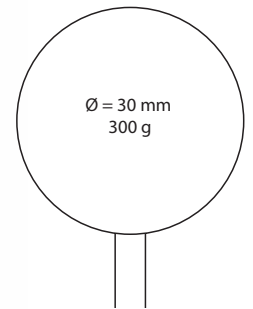
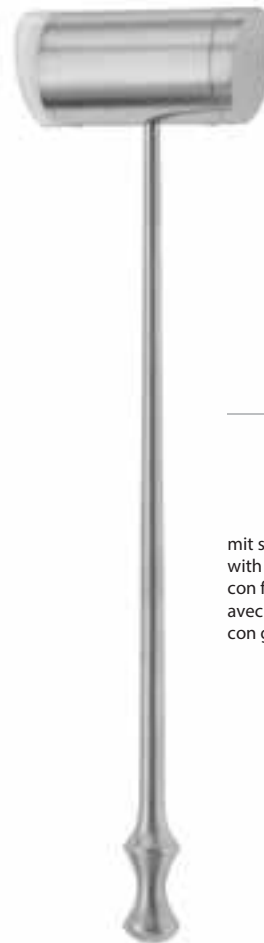

24 cm - 9 1/2"

67.40.75

Guillen

mit schrägen Flächen
with inclined facings
con frentes oblicuas
avec joues obliques
con guancie inclinate



TREVALLi

Hämmer
Mallet
Martillo
Maillet
Martelli



Ermöglicht gedämpfte und rückschlagsfreie Schläge mit präziser Führung.
Allows dampened and precisely guided impacts without resilience.
Permite golpes precisos, amortiguados y sin retroceso.
Permet des coups précis, amortis et sans recul.
Permette di effettuare colpi morbidi e privi di contracolpo con una guida precisa.

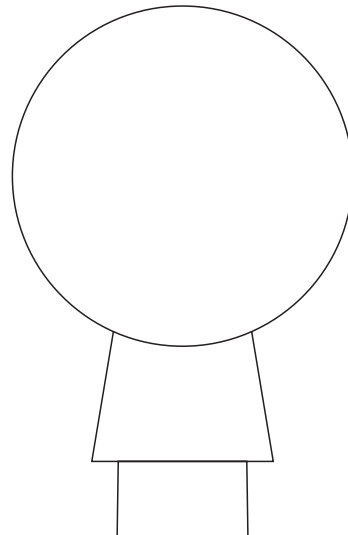

26 cm - 10 1/4"

Ø = 35 mm, 150 g **27.10.31**

Ø = 45 mm, 240 g **27.10.32**

Ø = 50 mm, 330 g **27.10.33**

aus NOVOTEX-Kunststoff (autoklavierbar bis 134 °C bei 3 bar)
made of NOVOTEX plastic (autoclavable up to 134 °C at 3 bar)
de materia plástica NOVOTEX (autoclavable hasta 134 °C bajo presión de 3 bar)
en matière plastique NOVOTEX (autoclavable à 134 °C sous pression de 3 bars)
di plastica NOVOTEX (autoclavabile fino a 134 °C sotto pressione di 3 bar)



TREVALLi

Flach- und Hohlmeißel
Chisels and Gouges
Cinceles y gubias
Ciseaux burins et gouges
Scalpelli e sgorbie

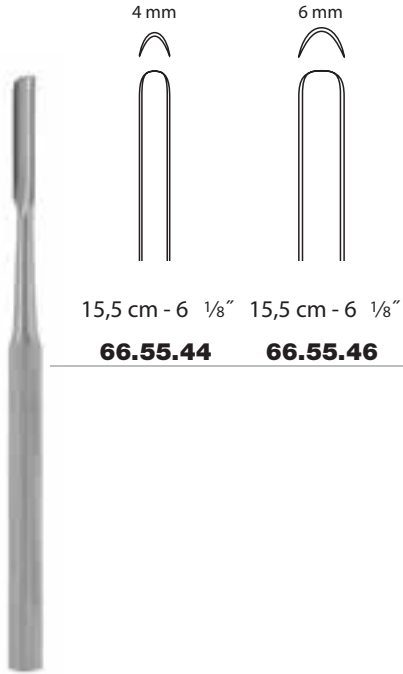

15,5 cm - 6 1/8" 15,5 cm - 6 1/8"
66.55.44 **66.55.46**

Freer

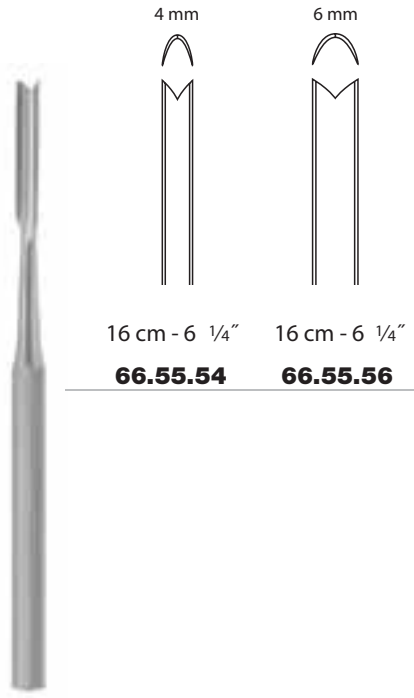

16 cm - 6 1/4" 16 cm - 6 1/4"
66.55.54 **66.55.56**

Ballenger



16 cm - 6 1/4"
66.55.95

Faulkner

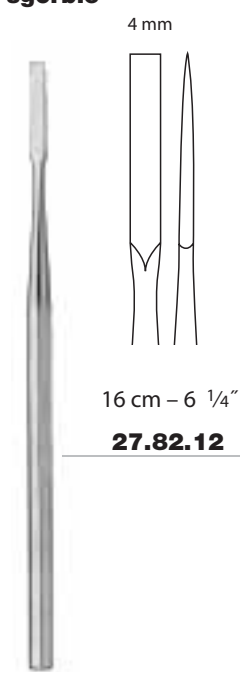

16 cm - 6 1/4"
27.82.12

West

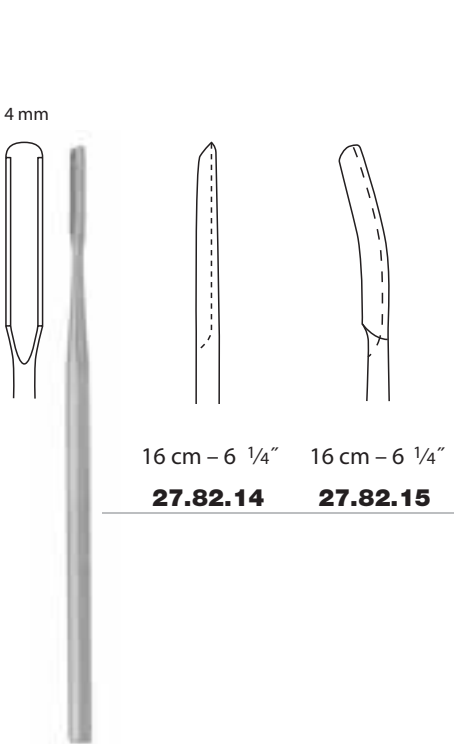

16 cm - 6 1/4" 16 cm - 6 1/4"
27.82.14 **27.82.15**

West

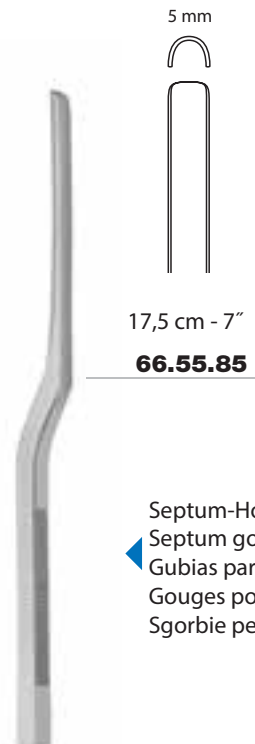

17,5 cm - 7"
66.55.85

Killian



17,5 cm - 7"
66.55.90

Killian-Claus

Septum-Hohlmeißel
Septum gouges
Gubias para el tabique nasal
Gouges pour la cloison nasale
Sgorbie per il setto nasale



TREVALLi

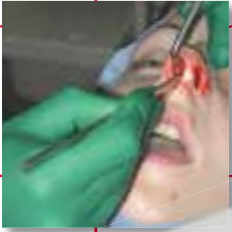

Cottle-Gubisch

Sehr flache Schnittkante - die eingestellte Osteotomie-Ebene bleibt kontinuierlich erhalten und führt zu einer präzisen Durchtrennung.

Extremely flat cutting edge - the set osteotomy level is continuously retained, leading to precise detachment.

Canto de corte muy plano - el nivel de osteotomía ajustado se mantiene continuado y permite una separación precisa.

Arête de coupe très plate - le plan d'ostéotomie qui a été réglé demeure de façon continue et conduit à une séparation précise.

Spigolo tagliente molto piatto - la il livello prestabilito della osteotomia rimane in modo continuo e porta ad una separazione precisa.

**Flachmeißel
Chisels
Cinceles
Ciseaux burins
Scalpelli**

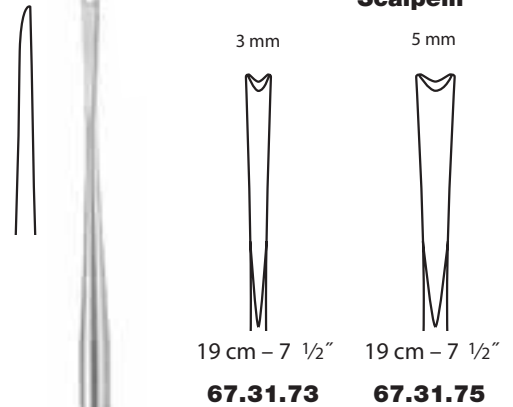

Walter

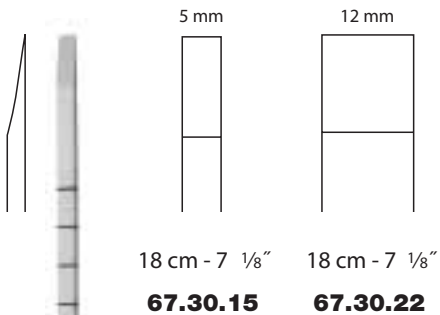

Hohlschliff
Hollow cut
Vaciado hueco
Rectification en creux
Levigatura vuota

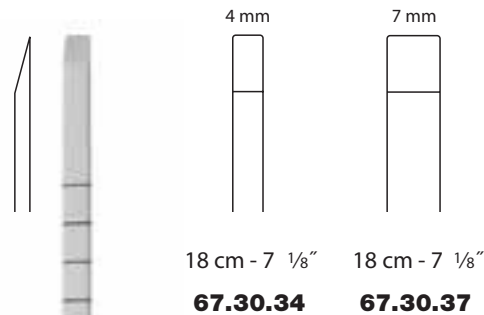

graduirt
graduated
graduada
graduado
graduata

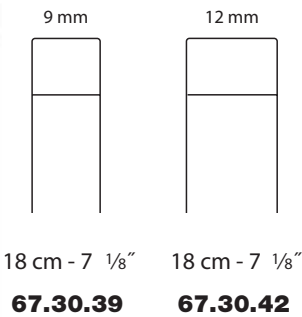

Cottle-Gubisch

Cottle



TREVALLi

Osteotome, Flachmeißel
Osteotomes, Chisels
Osteótomos, Cinceles
Ostéotomes, Ciseaux burins
Osteotomi, Scalpelli

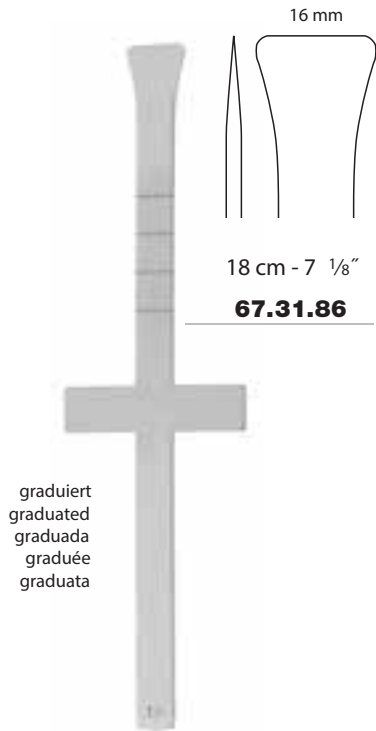

graduiert
graduated
graduada
graduée
graduata

Cottle

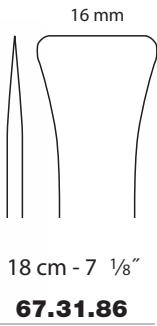

16 mm
18 cm - 7 1/8"
67.31.86

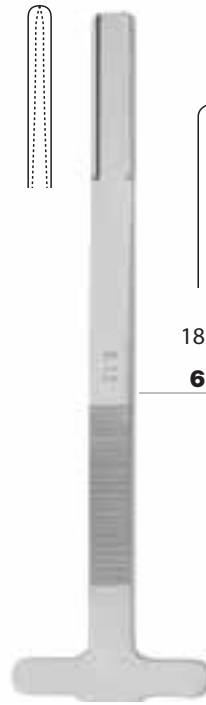

Rubin

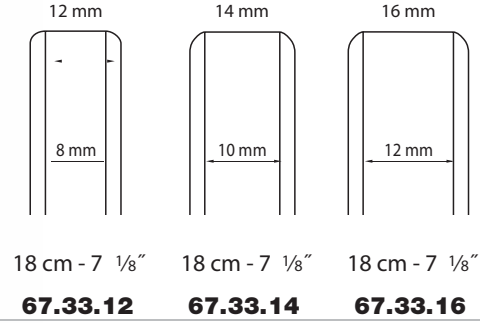

12 mm
14 mm
16 mm
8 mm
10 mm
12 mm
18 cm - 7 1/8"
18 cm - 7 1/8"
18 cm - 7 1/8"
67.33.12 **67.33.14** **67.33.16**

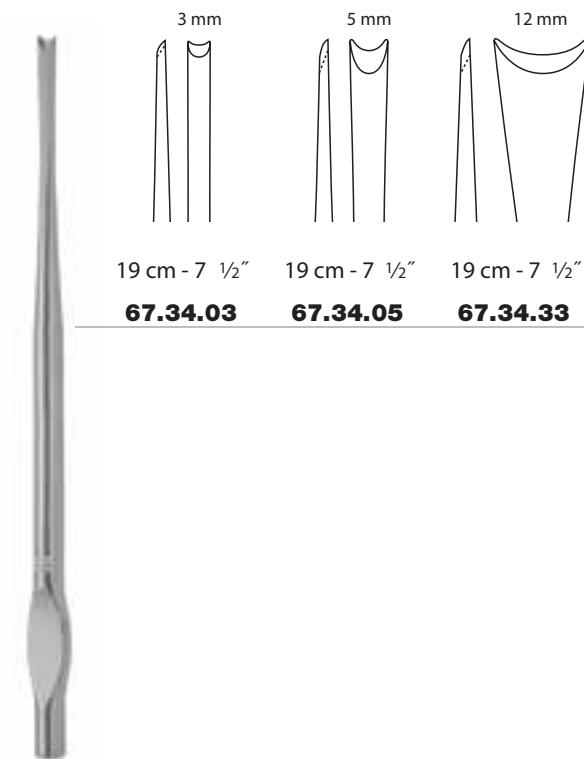

Walter

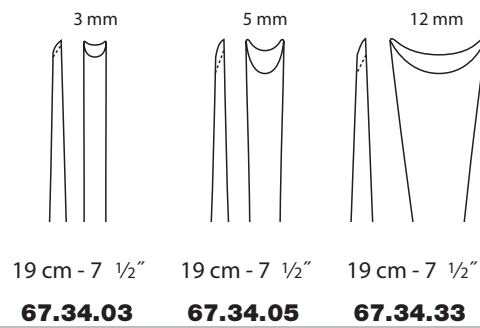

3 mm
5 mm
12 mm
19 cm - 7 1/2"
19 cm - 7 1/2"
19 cm - 7 1/2"
67.34.03 **67.34.05** **67.34.33**



TREVALLi

Osteotome
Osteotomes
Osteotomos
Ostéotomes
Osteotomi

**Osteotome, Flachmeißel
Osteotomes, Chisels
Osteótomos, Cinceles
Ostéotomes, Ciseaux burins
Osteotomi, Scalpelli**



Walter

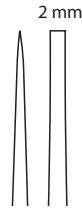

19 cm - 7 1/2"
67.34.22

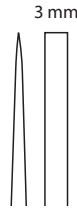

19 cm - 7 1/2"
67.34.23



19 cm - 7 1/2"
67.34.24

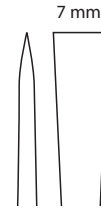

19 cm - 7 1/2"
67.34.27

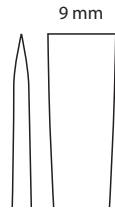

19 cm - 7 1/2"
67.34.29

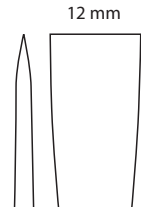

19 cm - 7 1/2"
67.34.32



19 cm - 7 1/2"
67.34.56



McIndoe



16 cm - 6 1/4"
67.36.08



16 cm - 6 1/4"
67.36.10



16 cm - 6 1/4"
67.36.12



16 cm - 6 1/4"
67.36.15



Moberg

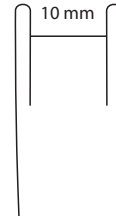

18 cm - 7 1/8"
67.36.30

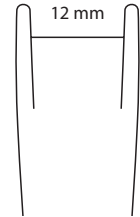

18 cm - 7 1/8"
67.36.32

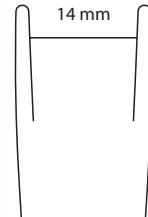

18 cm - 7 1/8"
67.36.34

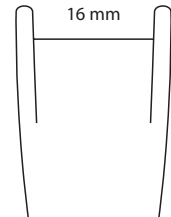

18 cm - 7 1/8"
67.36.36



TREVALLi

**Osteotome
Osteotomes
Osteotomos
Ostéotomes
Osteotomi**

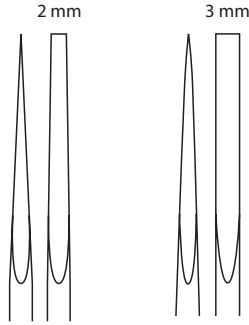

18,5 cm - 7 1/4" 18,5 cm - 7 1/4"

67.30.52 67.30.53

Aluminiumgriff
Aluminium handle
Mango de aluminio
Manche en aluminium
Manico in alluminio



67.30.53

- Ideal für direkte, transversale Osteotomie durch die Haut
- Sicherer Halt und präzise Führung
- Ideal for direct transversal osteotomy
- Reliable grip and precise guidance
- Ideal para osteotomía directa y transversal transcutánea
- Para un manejo seguro y preciso
- Idéal pour l'ostéotomie directe et transversale transcutanée
- Tenue sûre et guidage précis
- Ideale per le osteotomie transcutanee dirette e trasversali
- Permettendo una tenuta stabile e una guida precisa

Gubisch

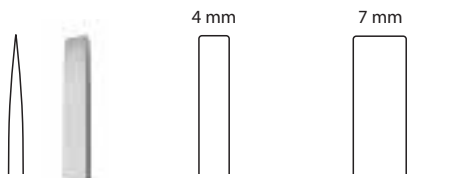

18 cm - 7 1/8" 18 cm - 7 1/8"

67.30.04 67.30.07

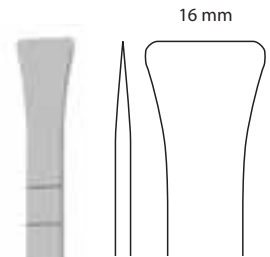

18 cm - 7 1/8"

67.31.16

graduiert
graduated
graduada
graduée
graduata

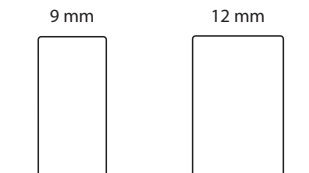

18 cm - 7 1/8" 18 cm - 7 1/8"

67.30.09 67.30.12

graduiert
graduated
graduada
graduée
graduata

Cottle

Cottle



TREVALLi

Osteotome
Osteotomes
Osteotomos
Ostéotomes
Osteotomi

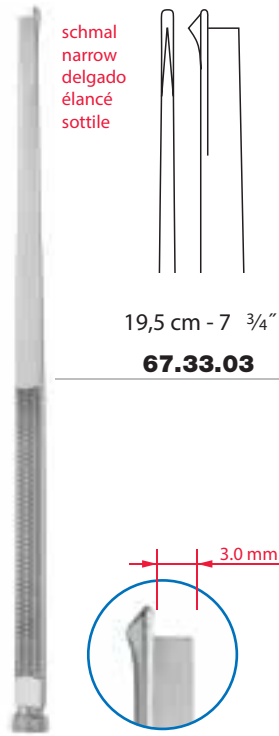

schmal
narrow
delgado
élancé
sottile

19,5 cm - 7 3/4"

67.33.03

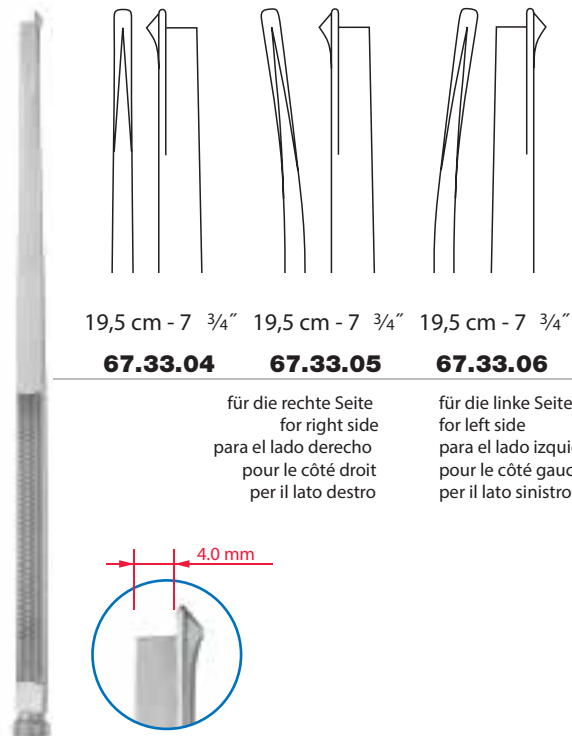

19,5 cm - 7 3/4"

19,5 cm - 7 3/4"

19,5 cm - 7 3/4"

67.33.04

67.33.05

67.33.06

für die rechte Seite
for right side
para el lado derecho
pour le côté droit
per il lato destro

für die linke Seite
for left side
para el lado izquierdo
pour le côté gauche
per il lato sinistro

Fanous-Gubisch

- ▶ Der Operateur orientiert sich mittels des lateralen Führungsdorns über die Meißelposition
- ▶ Minimale Traumatisierung
- ▶ Bevorzugte Anwendung für die laterale Osteotomie bei enoralem und endonasalem Zugang
- ▶ The surgeon orientates himself by means of the lateral guiding thorn about the position of the chisel
- ▶ Minimal traumatization
- ▶ Preferred application for lateral osteotomy with enoral and endonasal access
- ▶ El cirujano se orienta mediante la espina guía lateral para determinar la posición del cincel
- ▶ Traumatización mínima
- ▶ Aplicación preferida para la osteotomía lateral con acceso intraoral y intranasal
- ▶ L'opérateur s'oriente par l'épine latérale de guidage pour déterminer la position du burin
- ▶ Traumatisme minimal
- ▶ S'utilise surtout pour l'ostéotomie latérale sous accès énorale et endonasale
- ▶ Il chirurgo può determinare la posizione dello scalpello attraverso la spina guida
- ▶ Traumatizzazione minimo
- ▶ Applicazione preferita per osteotomia laterale con accesso enorale ed endonasale

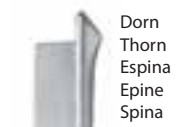

Dorn
Thorn
Espina
Epine
Spina

Fanous

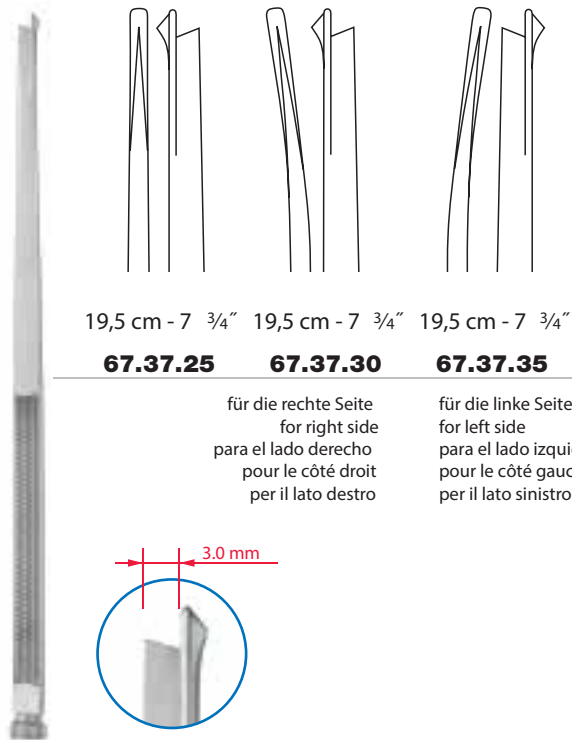

19,5 cm - 7 3/4"

19,5 cm - 7 3/4"

19,5 cm - 7 3/4"

67.37.25

67.37.30

67.37.35

für die rechte Seite
for right side
para el lado derecho
pour le côté droit
per il lato destro

für die linke Seite
for left side
para el lado izquierdo
pour le côté gauche
per il lato sinistro

Schrom



TREVALLi

**Osteotome
Osteotomes
Osteotomos
Ostéotomes
Osteotomi**

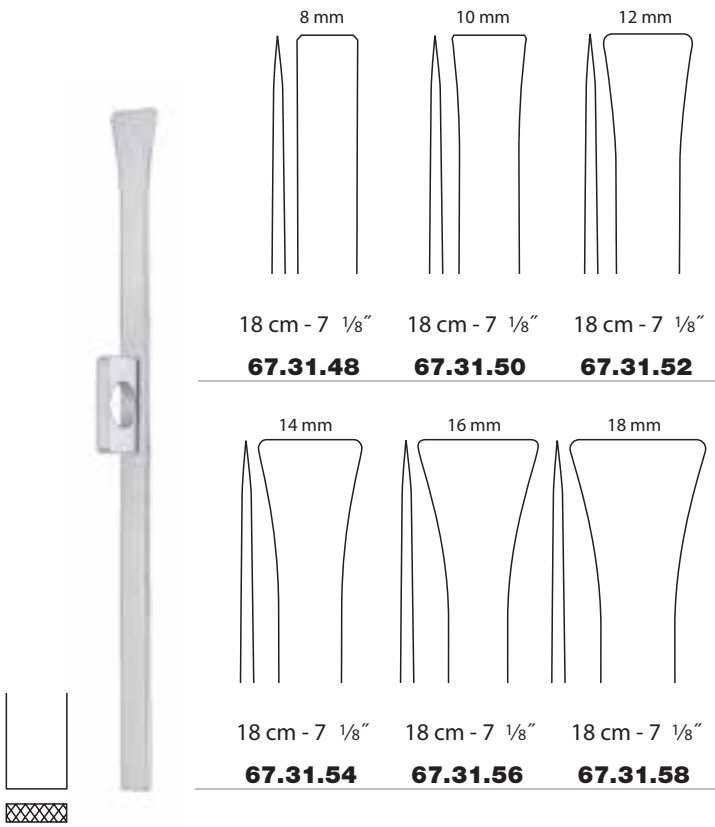

Rubin

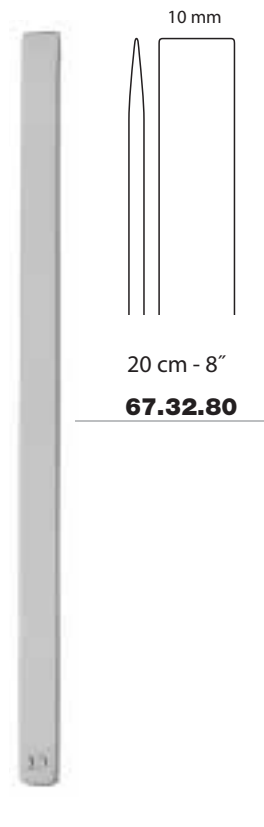

Cottle

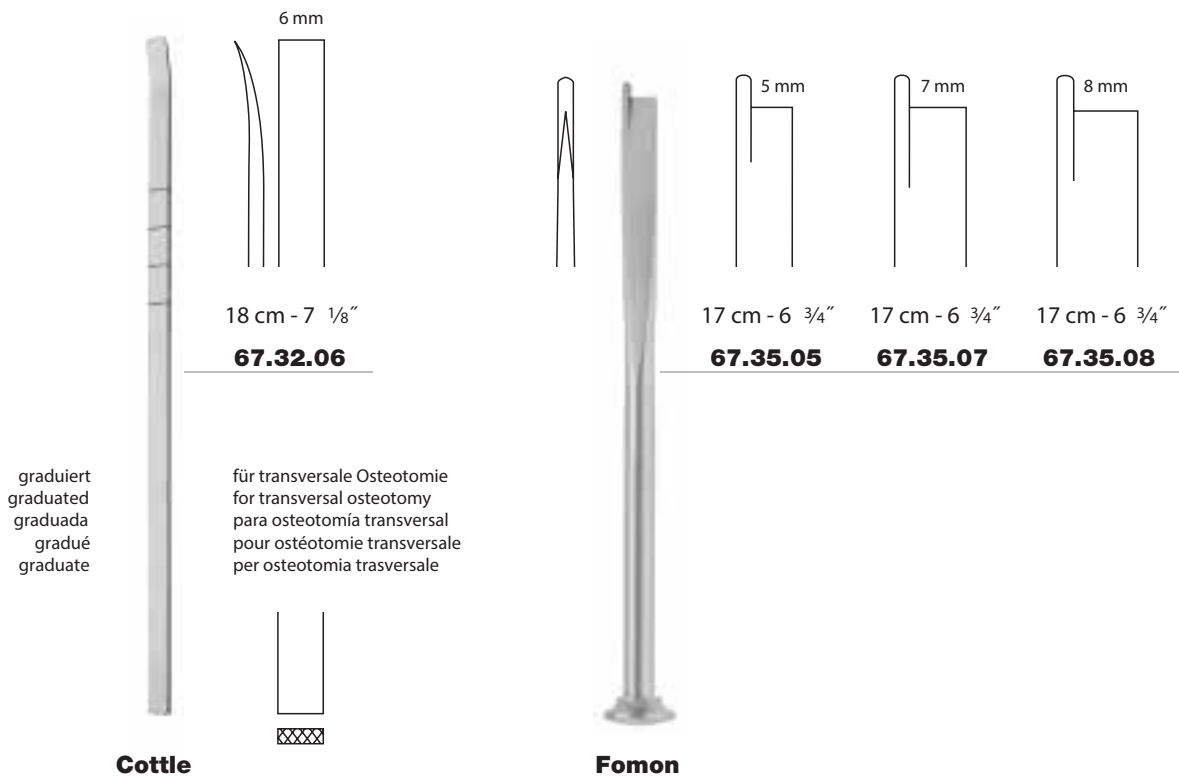

Cottle

Fomon



TREVALLi

**Osteotome
Osteotomes
Osteotomos
Ostéotomes
Osteotomi**

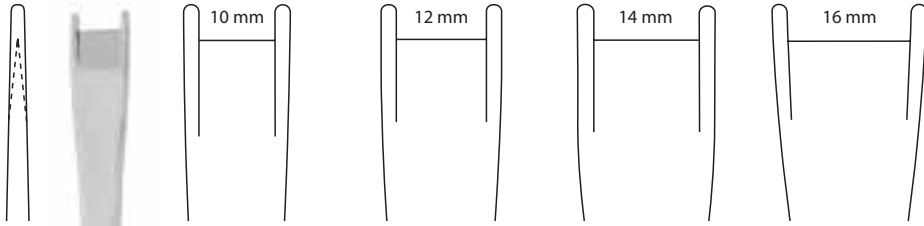

16 cm - 6 1/4"

67.37.10

16 cm - 6 1/4"

67.37.12

16 cm - 6 1/4"

67.37.14

16 cm - 6 1/4"

67.37.16

Cinelli



67.37.20

für die laterale Osteotomie
for lateral osteotomy
para la osteotomía lateral
pour l'ostéotomie latérale
per la osteotomia laterale

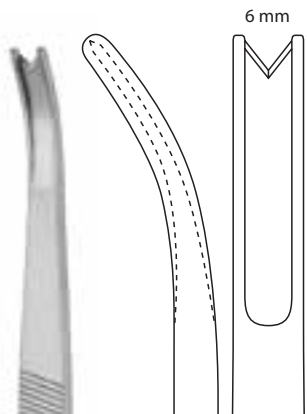

18 cm - 7 1/8"

67.37.20

Blume

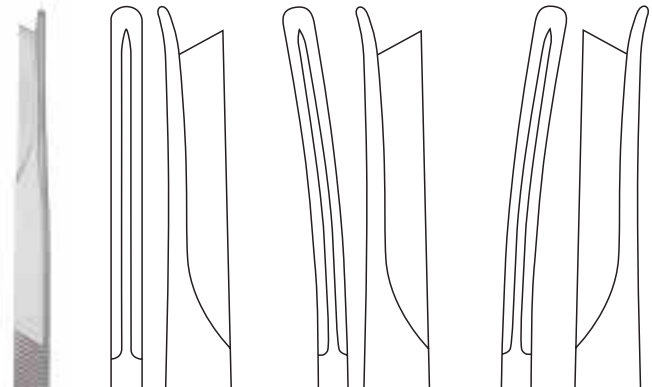

18 cm - 7 1/8"

67.38.10

18 cm - 7 1/8"

67.38.11

18 cm - 7 1/8"

67.38.12

Silver

für die rechte Seite
for right side
para el lado derecho
pour le côté droit
per il lato destro

für die linke Seite
for left side
para el lado izquierdo
pour le côté gauche
per il lato sinistro

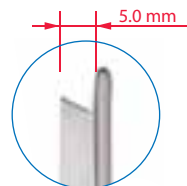



TREVALLi

**Punktionskanülen
Puncture Needles
Cánulas para punción
Canules à ponction
Cannule per puntura**

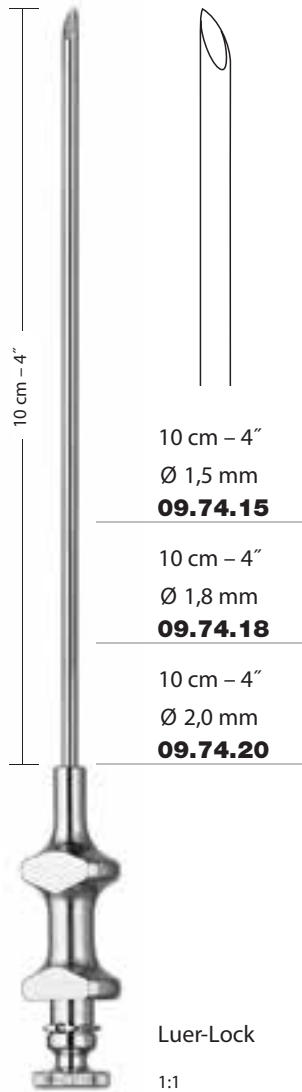

Lichtwitz

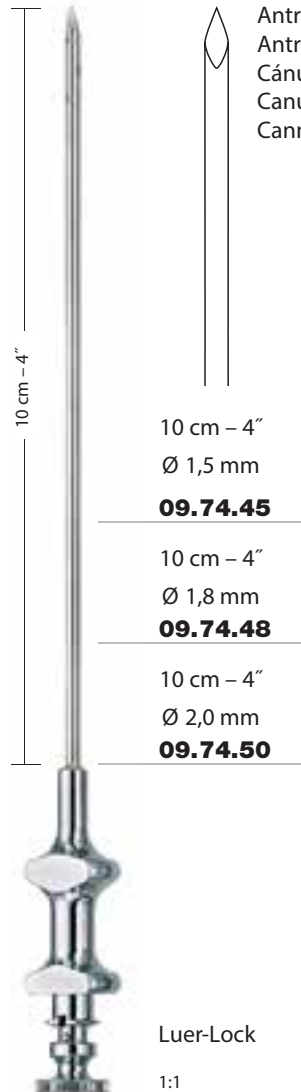

**Lichtwitz-
Eicken**

Antrumkanüle
Antrum cannulas
Cánula para el antro
Canule pour l'antre
Cannula per antro

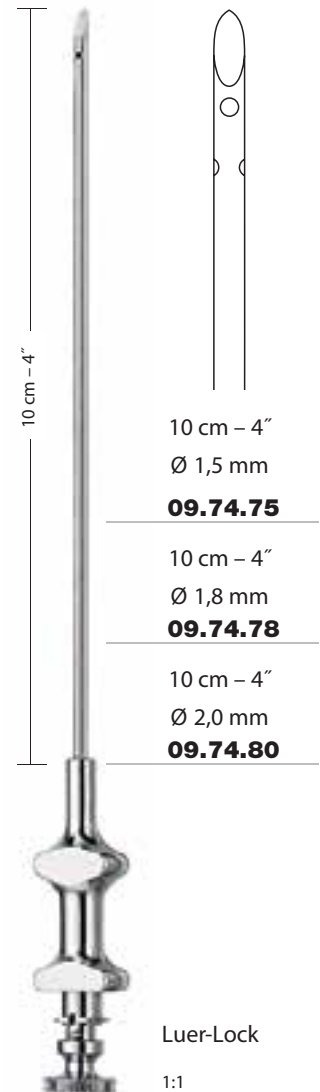

Vogel

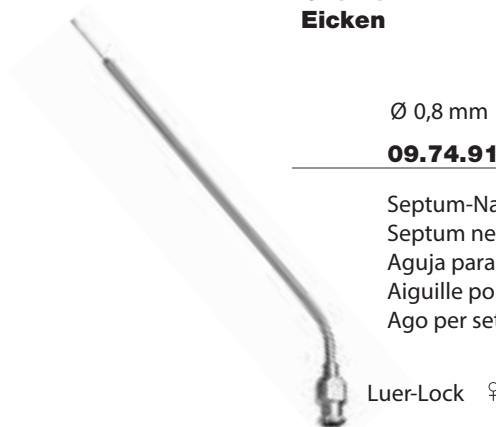

Ø 0,8 mm

09.74.91

Septum-Nadel
Septum needle
Aguja para septum
Aiguille pour cloison nasale
Ago per setto

Luer-Lock ♀



TREVALLi

Saug- und Spülinstrumente
Suction and Irrigating Instruments
Instrumentos de aspiración y de lavado
Instrumenti à aspiration et à irrigation
Strumenti per aspirazione e lavaggio

● 2,5 mm

● 3,0 mm

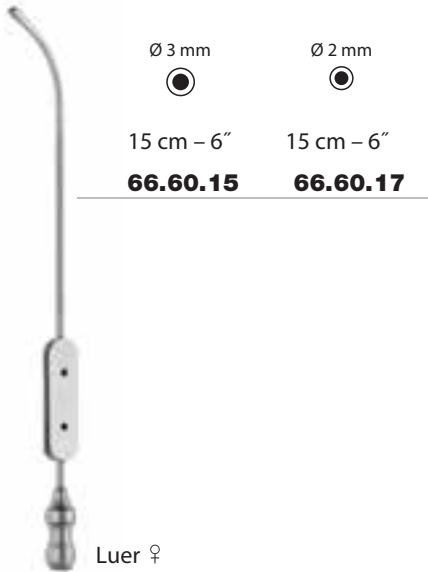

Ø 3 mm

Ø 2 mm

15 cm - 6"

15 cm - 6"

66.60.15

66.60.17

Luer ♀

Eicken

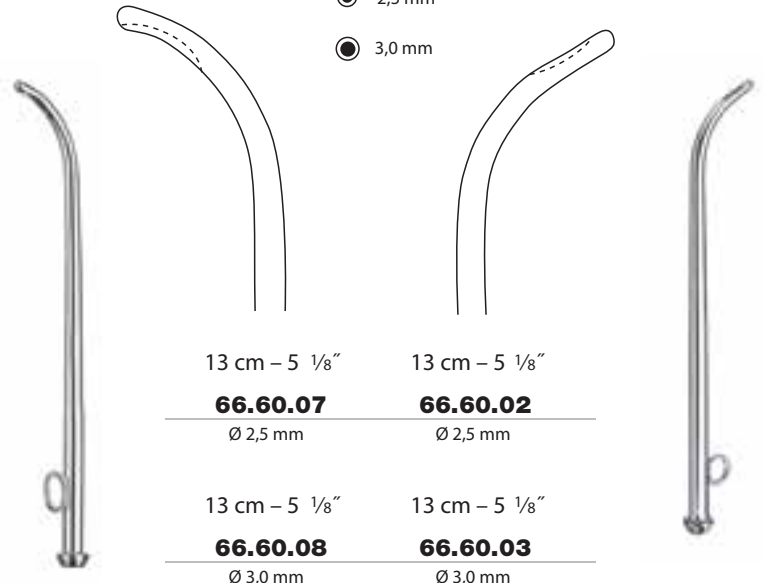

13 cm - 5 1/8"

13 cm - 5 1/8"

66.60.07

66.60.02

Ø 2,5 mm

Ø 2,5 mm

13 cm - 5 1/8"

13 cm - 5 1/8"

66.60.08

66.60.03

Ø 3,0 mm

Ø 3,0 mm

Siebenmann

Siebenmann

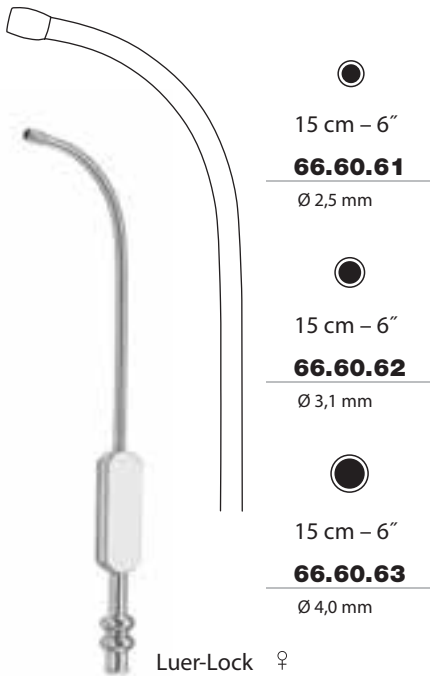

●

15 cm - 6"

66.60.61

Ø 2,5 mm

●

15 cm - 6"

66.60.62

Ø 3,1 mm

●

15 cm - 6"

66.60.63

Ø 4,0 mm

Luer-Lock ♀

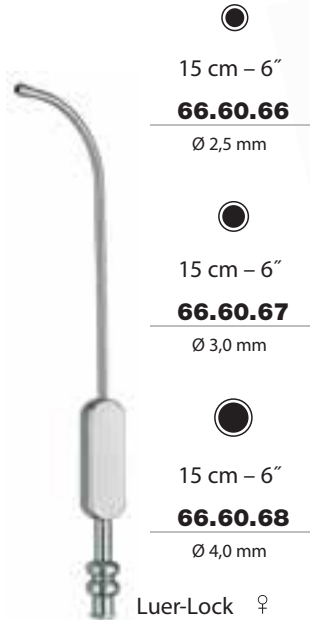

●

15 cm - 6"

66.60.66

Ø 2,5 mm

●

15 cm - 6"

66.60.67

Ø 3,0 mm

●

15 cm - 6"

66.60.68

Ø 4,0 mm

Luer-Lock ♀



Koagulationssaugrohr
Suction tube for coagulation
Tubo de aspiración para coagulación
Tube d'aspiration pour coagulation
Tubo d'aspirazione per coagulazione

66.60.52

Ø 2,5 mm

Nutzlänge 10 cm
Working length 10 cm - 4"
Largo útil 10 cm
Longueur utile 10 cm
Lunghezza utile 10 cm

biegsam
malleable
maleable
malléable
malleabile



TREVALLi

Saug- und Spülinstrumente
Suction and Irrigating Instruments
Instrumentos de aspiración y de lavado
Instrumentes à aspiration et à irrigation
Strumenti per aspirazione e lavaggio



Eicken



Eicken



Killian



Killian



TREVALLi

Saug- und Spülinstrumente
Suction and Irrigating Instruments
Instrumentos de aspiración y de lavado
Instrumenti à aspirazione et à irrigation
Strumenti per aspirazione e lavaggio

Ø 2 mm



18 cm – 7 1/8"

66.60.35

Luer

Killian

Ø 2 mm



15 cm – 6"

66.60.41

Luer

van Alyea

aus Silber
Sterling silver
de plata pura
en argent pur
in argento puro

Ø 2 mm

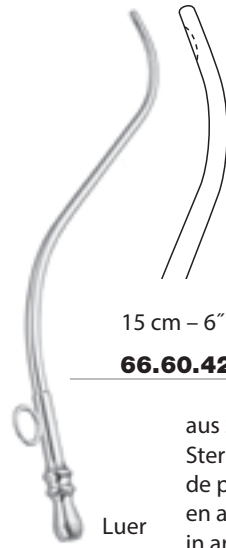

15 cm – 6"

66.60.42

Luer

van Alyea

aus Silber
Sterling silver
de plata pura
en argent pur
in argento puro

Ø 1,5 mm



12 cm – 4 3/4"

66.60.45

Luer-Lock

van Alyea

Ø 1,5 mm



12 cm – 4 3/4"

66.60.46

Luer-Lock

van Alyea

Ø 2 mm



11 cm – 4 3/8"

66.60.50



TREVALLI

Saug- und Spülinstrumente
Suction and Irrigating Instruments
Instrumentos de aspiración y de lavado
Instrumentes à aspiration et à irrigation
Strumenti per aspirazione e lavaggio

Ø 2 mm

12 cm - 4 3/4"
Nutzlänge
Working length
Largo útil
Longueur utile
Lunghezza utile

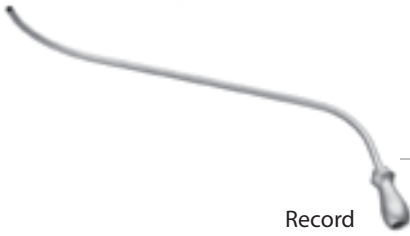

66.60.71

Record
Hartmann

Ø 2 mm

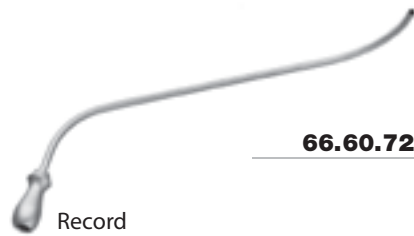

66.60.72

Record
Hartmann



15 cm - 6"
Nutzlänge
Working length
Largo útil
Longueur utile
Lunghezza utile

1

Charr. 10
09.82.21

biegsam
malleable
maleable
malléable
malleabile

Kahn-Frazier



2

Charr. 10
09.82.22

biegsam
malleable
maleable
malléable
malleabile

Kahn-Frazier



5-9 cm
graduirt
graduated
graduación
gradué
graduato

10 cm - 4"
Nutzlänge
Working length
Largo útil
Longueur utile
Lunghezza utile

Charr. 6
09.82.36

Charr. 8
09.82.38

Charr. 10
09.82.40

Frazier



TREVALLi

Saug- und Spülinstrumente
Suction and Irrigating Instruments
Instrumentos de aspiración y de lavado
Instrumentes à aspiration et à irrigation
Strumenti per aspirazione e lavaggio



11 cm - 4 3/8"
Nutzlänge
Working length
Largo útil
Longueur utile
Lunghezza utile

Frazier



Charr. 10
09.82.23



Charr. 10
09.82.24

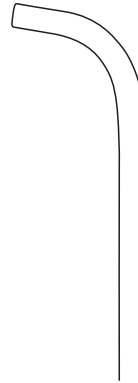

Charr. 10
09.82.26

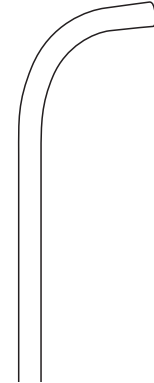

Charr. 10
09.82.25



12 cm - 5"
Nutzlänge
Working length
Largo útil
Longueur utile
Lunghezza utile

Frazier (Fergusson)

Charr. 6
09.83.26

Charr. 8
09.83.28

Charr. 10
09.83.30

Charr. 12
09.83.32

Charr. 15
09.83.34



Schaft isoliert
Insulated shaft
Vástago aislado
Tige isolée
Asta isolata

Fergusson

Charr. 7
09.83.47

Charr. 9
09.83.49

Charr. 11
09.83.51

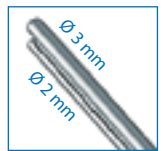

62.23.30



9 cm - 3 1/2"
Nutzlänge
Working length
Largo útil
Longueur utile
Lunghezza utile



TREVALLi

Stablehre, Nadelhalter
Gauge Rod, Needle Holder
Calibre, Porta-aguja
Guide, Porte-aiguille
Calibro, Portaghi



Joseph



graduirt in cm
graduated in cm
graduado en cm
gradu  en cm
graduato in cm

17 cm - 6 3/4"

67.90.05

Schleimhaut-Nadelhalter
Mucosa needle holder
Porta-aguja para mucosa
Porte-aiguille pour muqueuse
Portaghi per mucosa

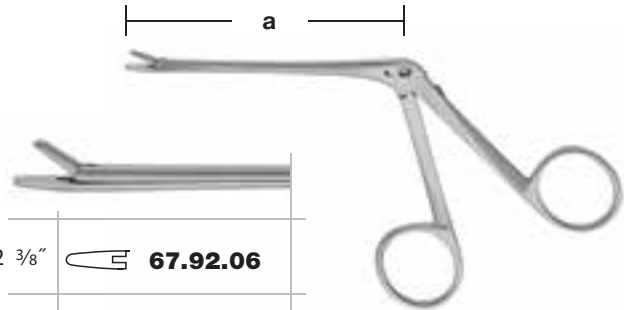

Cottle-Masing

a = 6 cm - 2 3/8"



67.92.06

a = 9 cm - 3 1/2"



67.92.09

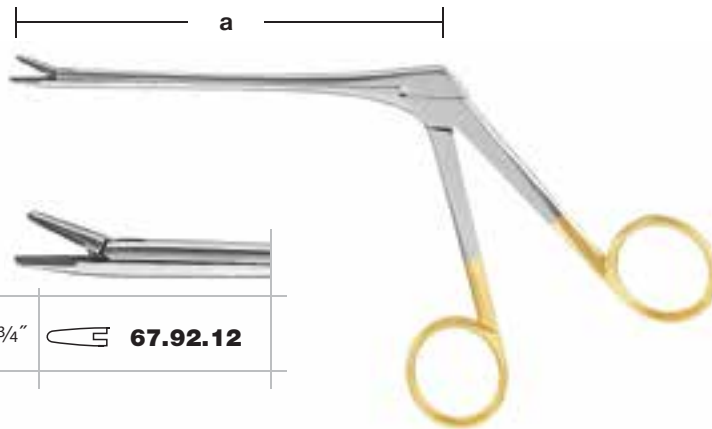

Sulsenti Winter "HM"

a = 12 cm - 4 3/4"



67.92.12

"HM"

Hartmetall
Tungsten carbide
Carburo de tungsteno
Carbure de tungst ne
Carburo di tungsteno



TREVALLi

Sinuskopie-Zubehör
Accessories for Sinuscopy
Accesorios para sinoscopia
Accessoires pour sinuscopie
Accessori per sinoscopia

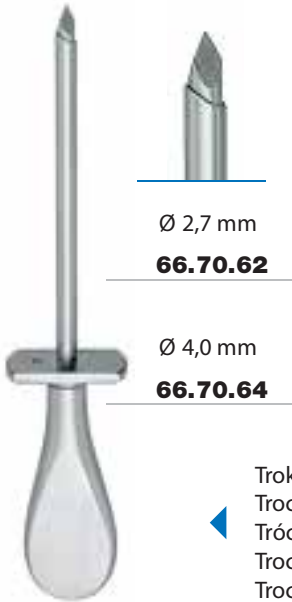

Ø 2,7 mm

66.70.62

Ø 4,0 mm

66.70.64

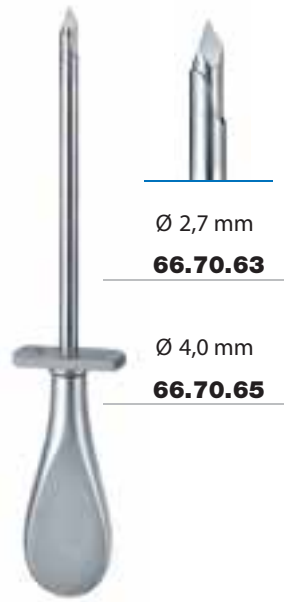

Ø 2,7 mm

66.70.63

Ø 4,0 mm

66.70.65

◀ Trokare
Trocars
Trócares
Trocarts
Trocar ▶

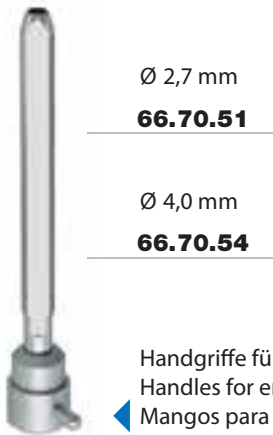

Ø 2,7 mm

66.70.51

Ø 4,0 mm

66.70.54

◀ Handgriffe für Endoskope
Handles for endoscopes
Mangos para endoscopios
Manches pour endoscopes
Manici per endoscopi ▶



Ø 2,7 mm

66.70.52

Ø 4,0 mm

66.70.55

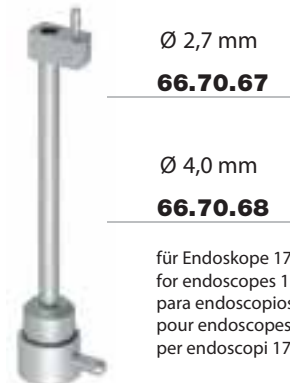

Ø 2,7 mm

66.70.67

Ø 4,0 mm

66.70.68

für Endoskope 175 mm
for endoscopes 175 mm
para endoscopios 175 mm
pour endoscopes 175 mm
per endoscopi 175 mm

Verlängerungen für Trocarhülsen
Extensions for trocar sleeves
Alargamientos para vainas de trocar
Rallonges pour douilles de trocarts
Estensori per guaine di trocar



TREVALLi

ENT INSTRUMENTS

Adenotomie · Tonsillektomie
Adenoidectomy · Tonsillectomy
Adenotomía · Amigdalotomía
Adénotomie · Amygdalectomie
Adenotomia · Tonsillectomia

trevalli@mweb.co.za



TREVALLi

Adenotome
Adenotomes
Adenotomos
Adénotomes
Adenotomi



Lieferumfang: 2 Klängen je Fig.
 Delivery with: 2 blades each size
 Incluido en cada unidad: 2 hojas de cada figura
 Inclus dans la livraison: 2 lames de chaque figure
 Dotazione: 2 lame per figura

23,5 cm – 9 1/4"

# 0	71.11.10
# 1	71.11.11
# 2	71.11.12
# 3	71.11.13

LaForce-Medicon



23,5 cm – 9 1/4"

# 0	71.11.50
# 1	71.11.51
# 2	71.11.52
# 3	71.11.53

Shambaugh

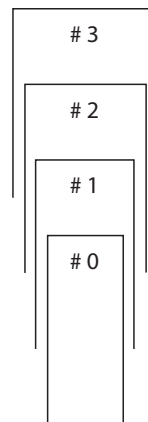

# 0	71.11.90	10 mm
# 1	71.11.91	13 mm
# 2	71.11.92	16 mm
# 3	71.11.93	19 mm

Ersatzklängen allein für LaFORCE-MEDICON und SHAMBAUGH Adenotome

Replacement blades only for LaFORCE-MEDICON and SHAMBAUGH adenotomes

Hojas de repuesto solas para el adenotomo LaFORCE-MEDICON y SHAMBAUGH

Lames de rechange seules pour adénotomes de LaFORCE-MEDICON et de SHAMBAUGH

Lame di ricambio sola per adenotomi LaFORCE-MEDICON e SHAMBAUGH



TREVALLi

Ringmesser
Adenoid Currettes
Cuchillos para vegetaciones adenoideas
Couteaux pour végétations adénoïdes
Coltelli anulari per vegetazioni adenoide



#0
10 mm
22 cm - 8 3/4"
71.36.10

#1
12 mm
22 cm - 8 3/4"
71.36.12

#2
14 mm
22 cm - 8 3/4"
71.36.14

#3
16 mm
22 cm - 8 3/4"
71.36.16

#4
18 mm
22 cm - 8 3/4"
71.36.18

Barnhill



8 mm
21,5 cm - 8 1/2"
71.32.08

Vogel



Shambaugh (Negus)

#0
10 mm
22 cm - 8 3/4"
71.47.10

#2
12 mm
22 cm - 8 3/4"
71.47.12

#3
14 mm
22 cm - 8 3/4"
71.47.14

#4
16 mm
22 cm - 8 3/4"
71.47.16

#5
18 mm
22 cm - 8 3/4"
71.47.18



TREVALLi

**Ringmesser
Adenoid Currettes
Cuchillos para vegetaciones adenoideas
Couteaux pour végétations adénoïdes
Coltelli anulari per vegetazioni adenoide**



Beckmann

mit Fangkorb
with basket
con cesto colector
avec panier
con cestello collettore

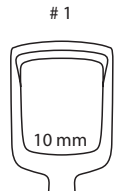

1
21,5 cm – 8 1/2"
71.34.10

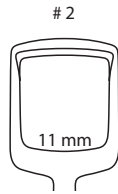

2
21,5 cm – 8 1/2"
71.34.11

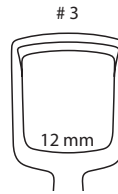

3
21,5 cm – 8 1/2"
71.34.12

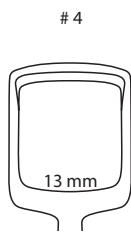

4
21,5 cm – 8 1/2"
71.34.13

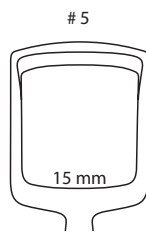

5
21,5 cm – 8 1/2"
71.34.15

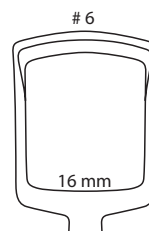

6
21,5 cm – 8 1/2"
71.34.16



Beckmann

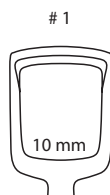

1
21,5 cm – 8 1/2"
71.34.60

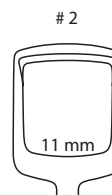

2
21,5 cm – 8 1/2"
71.34.61

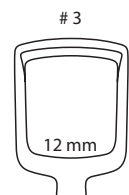

3
21,5 cm – 8 1/2"
71.34.62

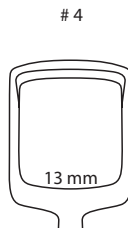

4
21,5 cm – 8 1/2"
71.34.63

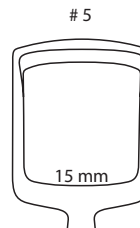

5
21,5 cm – 8 1/2"
71.34.65

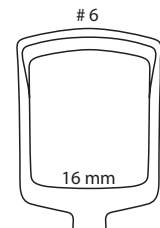

6
21,5 cm – 8 1/2"
71.34.66



TREVALLi



St. Clair-Thomson

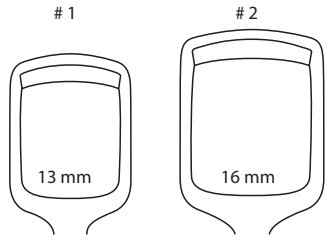

23,5 cm – 9 1/4" 23,5 cm – 9 1/4"

71.48.11 71.48.12

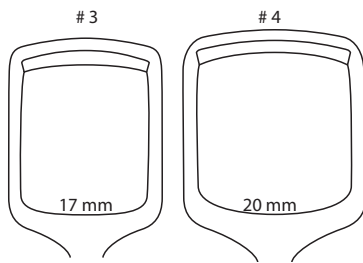

23,5 cm – 9 1/4" 23,5 cm – 9 1/4"

71.48.14 71.48.17

Ringmesser
Adenoid Currettes
Cuchillos para vegetaciones adenoideas
Couteaux pour végétations adénoïdes
Coltelli anulari per vegetazioni adenoide



Katz

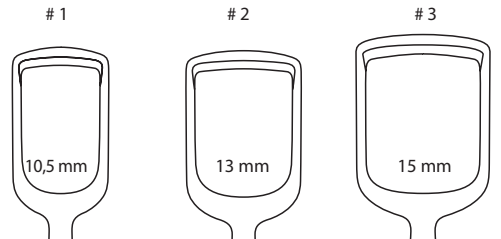

22 cm – 8 3/4" 22 cm – 8 3/4" 22 cm – 8 3/4"

71.45.12 71.45.13 71.45.15

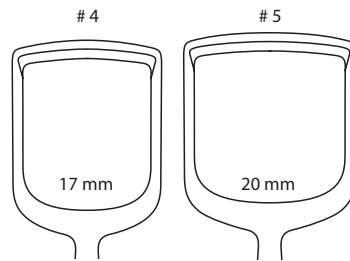

22 cm – 8 3/4" 22 cm – 8 3/4"

71.45.16 71.45.17



TREVALLi

Nasenrachenzangen
Naso-Pharyngeal Forceps
Pinzas naso-faringeas
Pinces rhino-pharyngiennes
Pinze naso-faringe

15 cm – 6"

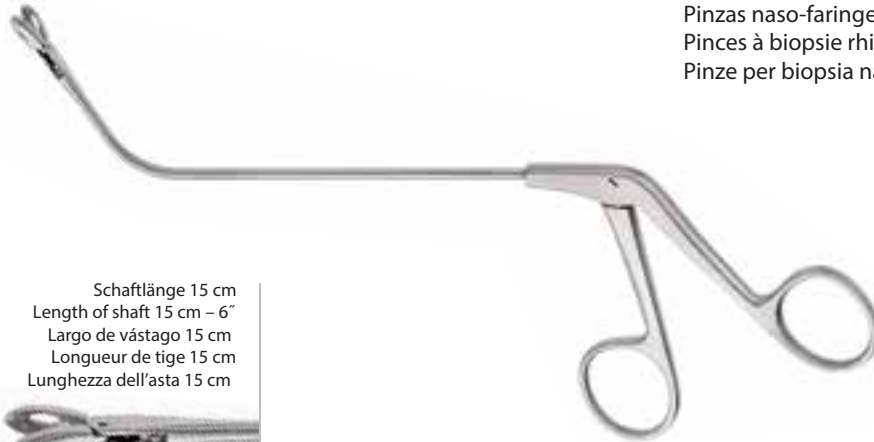

Nasenrachen-Biopsiezangen
Naso-pharyngeal biopsy forceps
Pinzas naso-faringeas para biopsia
Pinces à biopsie rhino-pharyngiennes
Pinze per biopsia naso faringe

Schaftlänge 15 cm
Length of shaft 15 cm – 6"
Largo de vástago 15 cm
Longueur de tige 15 cm
Lunghezza dell'asta 15 cm



71.50.50

Schaft
Shaft
Vástago
Tige
Asta
Ø **3,0 mm**

Jatho

15 cm – 6"

Schaftende biegsam
flexible working end
extremo de vástago maleable
extrémité de tige malléable
terminale dell'asta malleabile



rechts gebogen
right curved
curva derecha
courbe à droite
curva destra

links gebogen
left curved
curva izquierda
courbe à gauche
curva sinistra



71.50.62



71.50.63

Schaft
Shaft
Vástago
Tige
Asta
Ø **4,7 mm**



TREVALLi



Nasenrachenzangen
Naso-Pharyngeal Forceps
Pinzas naso-faringeas
Pinces rhino-pharyngiennes
Pinze naso-faringe

16,5 cm - 6 1/2"

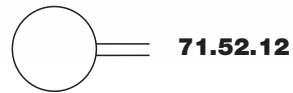

71.52.12

Hartmann

16,5 cm - 6 1/2"

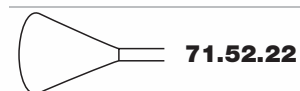

71.52.22

Meltzer



TREVALLI

**Nasenrachenzangen
Naso-Pharyngeal Forceps
Pinzas naso-faringeas
Pinces rhino-pharyngiennes
Pinze naso-faringe**



scharf
sharp
cortante
tranchant
tagliente

18 cm – 7 1/8"

71.50.18

St. Clair-Thomson



scharf
sharp
cortante
tranchant
tagliente

19 cm – 7 1/2"

71.50.19

Jurasz



TREVALLi



Uvula-Haken
Uvula retractors
Separadores uvulares
Ecarteurs uvulaires
Divaricatori per ugola

15 cm - 6"

71.63.18

a = 18 mm

15 cm - 6"

71.63.20

a = 20 mm

15 cm - 6"

71.63.22

a = 22 mm

Love

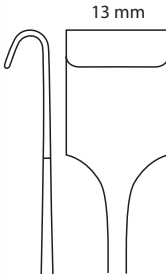

22 cm - 8 3/4"

71.64.23

Gaumensegelhalter
Soft palate retractors
Separadores del velo palatino
Releveurs du voile du palais
Retrattori per velo palatino

Nager

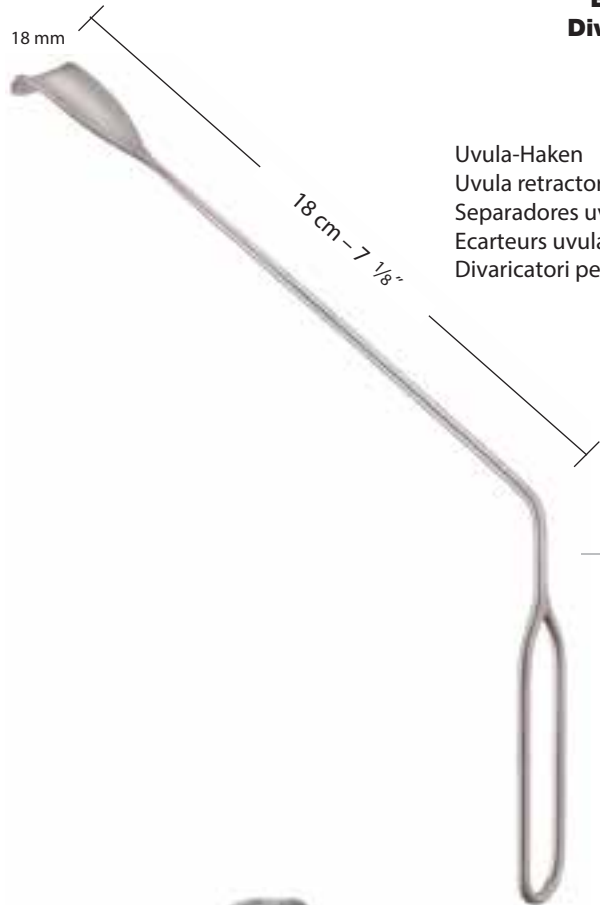

**Haken
Retractors
Separadores
Ecarteurs
Divaricatori**

Uvula-Haken
Uvula retractors
Separadores uvulares
Ecarteurs uvulaires
Divaricatori per ugola

18 cm - 7 1/8"

71.63.60

Lothrop



Gaumensegelhalter
Soft palate retractors
Separadores del velo palatino
Releveurs du voile du palais
Retrattori per velo palatino

17 cm - 6 3/4"

71.65.20

Haslinger



TREVALLI

Zungenspatel
Tongue Spatulas
Espátulas bucales
Spatules à langue
Spatole per lingua

20 mm



16 cm – 6 ¼"

72.00.01



Holz
Wood
Madera
Bois
Legno

18 mm



14,5 cm – 5 ¾"

72.00.10

20 mm



14 cm – 5 ½"

72.00.15

23 mm

18 mm



18 cm – 7 ⅛"

72.00.18

23 mm

Buchwald

22 mm



12 cm – 4 ¾"

72.00.27

29 mm

Doyen

30 mm



16 cm – 6 ¼"

72.00.28

33 mm

Doyen

23 mm



16,5 cm – 6 ½"

72.00.35

13 mm

Frenzel

14 mm



19 cm – 7 ½"

72.00.50

18 mm

Brünings



Verpackungseinheit "X" Stück
Packing unit "X" pieces
Paquete de "X" unidades
Emballage de "X" pièces
Confezione da "X" pezzi



TREVALLI

Zungenspatel, Fingerschützer, Zungendrucker
Tongue Spatulas, Finger Guard, Tongue Depressors
Espátulas bucales, Dedaleras, Bajalenguas
Spatules à langue, Protège-doigt, Abaisse-langue
Spatole per lingua, Proteggi dita, Abbassalingua

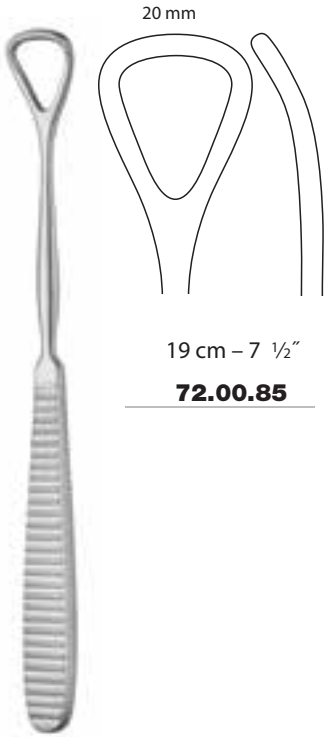

19 cm – 7 1/2"
72.00.85

Moritz-Schmidt



21 cm – 8 1/4"
72.00.95

LeMee

Fingerschützer
 Finger guard
 Dedaleras
 Protège-doigt
 Proteggi dita



Ø 17 – 21 mm

72.01.01
 # 1

Ø 19 – 24 mm

72.01.02
 # 2

Ø 21 – 26 mm

72.01.03
 # 3



72.01.15

Tobold

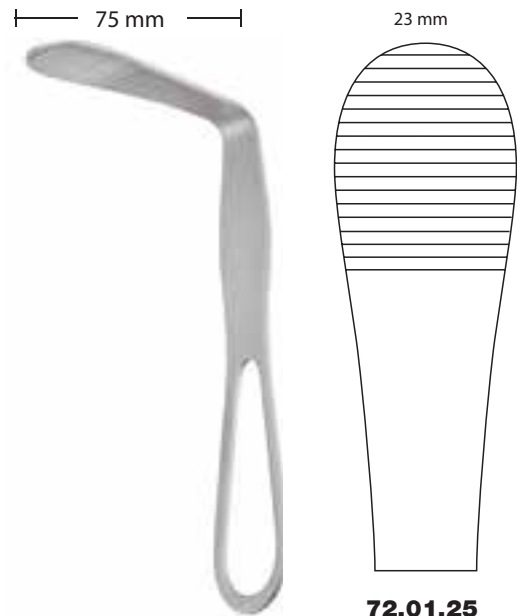

72.01.25

Hartmann



TREVALLi

**Zungendrucker, Lippen- und Wangenhalter
Tongue Depressors, Lip and Cheek Retractors
Bajalengua, Separadores de labios y mejillas
Abaisse-langues, Ecarteurs de lèvres et de joues
Abbassalingua, Divaricatori per labbra e guancie**



Andrews

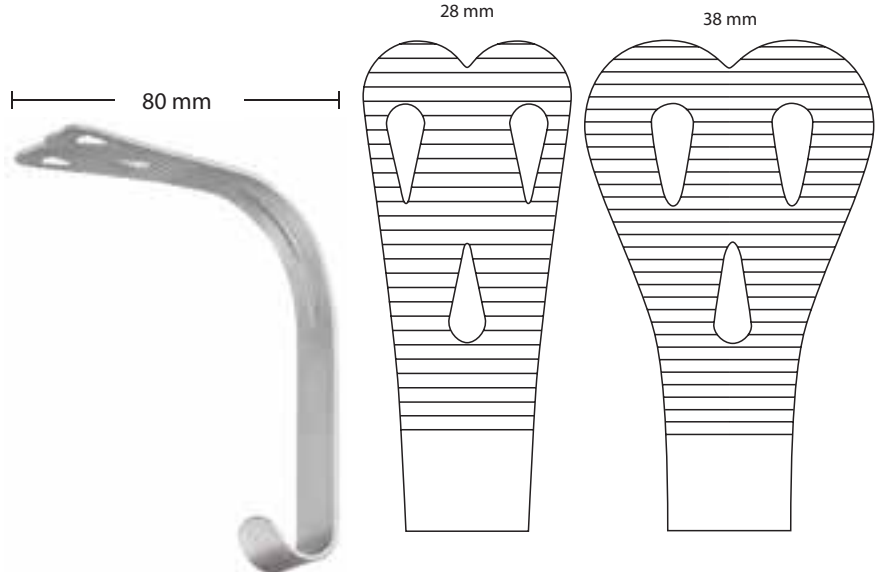

Wieder

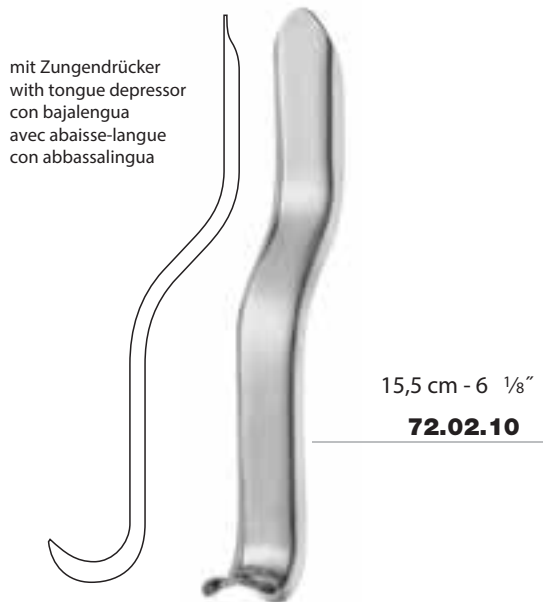

mit Zungendrucker
with tongue depressor
con bajalengua
avec abaisse-langue
con abbassalingua

Univ. Minnesota Cawood



mit Zungendrucker
with tongue depressor
con bajalengua
avec abaisse-langue
con abbassalingua

Sternberg



TREVALLi

**Mundsperrer
Mouth Gags
Abrebocas
Ouvre-bouches
Apribocca**



Ø 40 mm

72.04.10

Holz
Wood
Madera
Bois
Legno



Ø 40 mm

72.04.20

Hartgummi
Hard rubber
Ebonita
Ebonite
Ebanite

Mundkeile
Mouth gags
Abrebocas
Baillons
Apribocca



1:1

McKesson

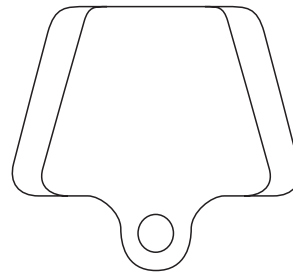

72.10.01 P₂

für Kleinkinder
for infants
para niños pequeños
pour petits enfants
per bambini piccoli

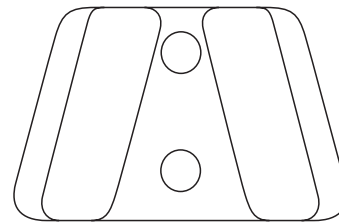

72.10.02 P₂

für Kinder
for children
para niños
pour enfants
per bambini

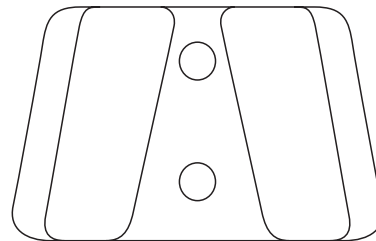

72.10.03 P₂

für Erwachsene
for adults
para adultos
pour adultes
per adulti



13 cm – 5 1/8"

72.05.05

Heister



Verpackungseinheit "X" Stück
Packing unit "X" pieces
Paquete de "X" unidades
Emballage de "X" pièces
Confezione da "X" pezzi



TREVALLi

**Mundsperrer
Mouth Gags
Abrebocas
Ouvre-bouches
Apribocca**



10 cm - 4"

72.05.10

für Kinder
for children
para niños
pour enfants
per bambini

15 cm - 6"

72.05.15

für Erwachsene
for adults
para adultos
pour adultes
per adulti

Molt



16 cm - 6 1/4"

72.05.45

Roser König



907.20.20

Silikonschutz allein, Paar
Silicone guard only, pair
Goma de silicona sola, par
Protection en silicone seule, paire
Protezione di silicone sola, paio



13 cm - 5 1/8"

72.05.60

Denhart



12,5 cm - 5"

72.05.61

Denhart



TREVALLI

**Mundsperrer, Zungenspatel
Mouth Gags, Tongue Spatulas
Abrebocas, Espátulas bucales
Ouvre-bouches, Spatules à langue
Apribocca, Spatole per lingua**



12,5 cm – 5"

72.05.63

Denhart-Hoefert

Bewegliche Auflagen
Movable supports
Soportes móviles
Support mobiles
Supporti mobili



Hanna

20 cm – 8"

72.00.52

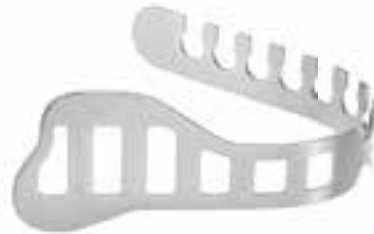

Claudinha

21 cm – 8 1/4"

72.00.56



14 cm - 5 1/2"

72.05.80

für Kinder
for children
para niños
pour enfants
per bambini

20 cm – 8"

72.05.81

für Erwachsene
for adults
para adultos
pour adultes
per adulti

Mason-Ackland

Zungenspatel verwendbar mit Mundsperrer:
Tongue spatulas for use with mouth gag:
Espátulas bucales aplicable con el abrebooca:
Spatules à langue à utiliser avec l'ouvre-bouche:
Spatole per lingua utilizzabile con l'apribocca:

Denhart-Hoefert
72.05.60
72.05.61
72.05.63



TREVALLi

**Mundsperrer
Mouth Gags
Abrebocas
Ouvre-bouches
Apribocca**



Jennings

9 cm – 3 1/2"	72.07.09
11 cm – 4 3/8"	72.07.11
13 cm – 5 1/8"	72.07.13
15 cm – 6"	72.07.15



Whitehead

9 cm – 3 1/2"	72.07.29
11 cm – 4 3/8"	72.07.31
13 cm – 5 1/8"	72.07.33
15 cm – 6"	72.07.35

automatisch nachstellende Sperre
automatically adjusting ratchet
cremallera de ajuste automático
crémaillère se réajustant automatiquement
cremagliera ad aggiustamento automatico

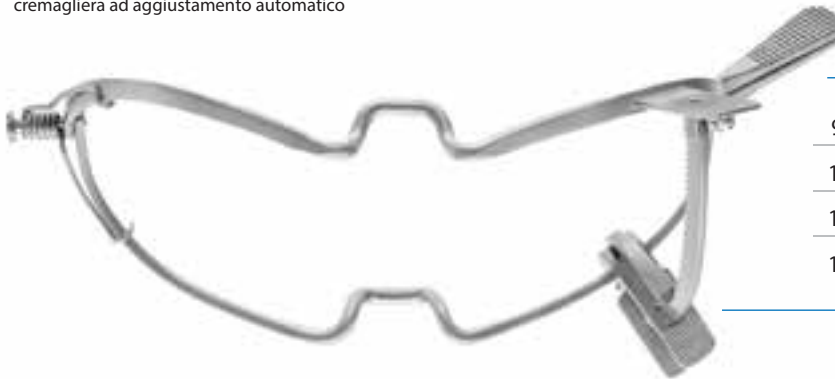

Medicon

9 cm – 3 1/2"	72.07.49
11 cm – 4 3/8"	72.07.51
13 cm – 5 1/8"	72.07.53
15 cm – 6"	72.07.55



TREVALLi

Mundsperrer
Mouth Gag
Abreboca
Ouvre-bouche
Apribocca

72.08.20

Rahmen allein, mit Zahn- und Wangenhaken
Frame only, with tooth hooks and cheek retractors
Bastidor solo, con ganchos dentales y separadores de mejillas
Cadre seul, avec crochets à dents et écarteurs pour joues
Telaio solo, con ganci dentali e divaricatori per guancia



72.08.00

Dingman

1
55 × 25 mm
72.08.11

2
60 × 27 mm
72.08.12

3
70 × 30 mm
72.08.13

Zungendrucker allein
Tongue depressors only
Bajalenguas sola
Abaisse-langue seule
Abbassalingua solo

komplett, bestehend aus:
complete, consisting of:
completo, compuesto de:
complet, se composant de:
completo, composto da:

1	Rahmen Frame Bastidor Cadre Telaio	1 × 72.08.20
2	Zahnhaken Tooth hooks Ganchos dentales Crochets à dents Ganci dentali	
2	Wangenhaken Cheek retractors Separadores de mejillas Ecarteurs pour joues Divaricatori per guancia	
3	Zungendrucker Tongue depressors Bajalenguas Abaisse-langue Abbassalingua	1 × 72.08.11 1 × 72.08.12 1 × 72.08.13



TREVALLI

**Mundsperrer
Mouth Gags
Abrebocas
Ouvre-bouches
Apribocca**

45.54.03

Rahmen allein, mit Zahn- und Wangenhaken
Frame only, with tooth hooks and cheek retractors
Bastidor solo, con ganchos dentales y separadores de mejillas
Cadre seul, avec crochets à dents et écarteurs pour joues
Telaio solo, con ganci dentali e divaricatori per guancia



45.54.02

Wang

1
55 x 32 mm
45.54.05

2
65 x 35 mm
45.54.06

3
75 x 38 mm
45.54.07

Zungendrucker allein
Tongue depressors only
Bajalenguas sola
Abaisse-langue seule
Abbassalingua solo

komplett, bestehend aus:
complete, consisting of:
completo, compuesto de:
complet, se composant de:
completo, composto da:

1	Rahmen Frame Bastidor Cadre Telaio	1x45.54.03
2	Zahnhaken Tooth hooks Ganchos dentales Crochets à dents Ganci dentali	
2	Wangenhaken Cheek retractors Separadores de mejillas Ecarteurs pour joues Divaricatori per guancia	
3	Zungendrucker Tongue depressors Bajalengua Abaisse-langue Abbassalingua	1x 45.54.05 1x 45.54.06 1x 45.54.07



TREVALLI

Mundsperrer
Mouth Gag
Abreboca
Ouvre-bouche
Apribocca



45.51.21

45.51.22

Standardgröße
Standard size
Tamaño estándar
Taille standard
Modello standard



45.51.27

für Kinder
for children
para niños
pour enfants
per bambini

45.51.02
Davis-Boyle

komplett, bestehend aus:
complete, consisting of:
completo, compuesto de:
complet, se composant de:
completo, composto da:

1	Rahmen Frame Bastidor Cadre Telaio	1x 45.51.22
5	Zungendrücker Tongue depressors Bajalengua Abaisse-langue Abbassalingua	1x 45.51.11 1x 45.51.12 1x 45.51.13 1x 45.51.14 1x 45.51.15



1
20 × 25 mm
45.51.11

2
22 × 65 mm
45.51.12

3
24 × 75 mm
45.51.13

4
25 × 90 mm
45.51.14

5
26 × 110 mm
45.51.15

904.50.02

Ersatz-Silikoneinlage für Gebissplatten
Spare silicone insert for bite plate
Plantilla de silicona de repuesto para placas de dentadura
Plaque de rechange en silicone pour plaques à denture
Piastra di ricambio in silicone per placche dentarie

Alle Rahmen und Zungendrücker der abgebildeten Mundsperrer sind untereinander austauschbar.
All frames and tongue blades for the mouth gags illustrated are interchangeable.
Todos los bastidores y bajalenguas de los abre bocas ilustrados son intercambiables entre ellos.
Tous les cadres et abaisse-langues faisant partie des ouvre-bouches illustrés ci-dessus sont interchangeables.
Tutti i telai ed abbassalingua degli apribocca illustrati sono intercambiabili tra loro e possono essere combinati facoltativamente.



TREVALLi

**Mundsperrer
Mouth Gags
Abrebocas
Ouvre-bouches
Apribocca**



45.52.22

Rahmen allein
Frame only
Bastidor solo
Cadre seul
Telaio solo

45.52.23

für Kinder
for children
para niños
pour enfants
per bambini

Davis-Mayer



1
29 × 70 mm
45.52.11

2
30,5 × 75 mm
45.52.12

3
31,5 × 80 mm
45.52.13

4
32,5 × 85 mm
45.52.14

5
33,5 × 95 mm
45.52.15

6
33,8 × 100 mm
45.52.16

7
34 × 105 mm
45.52.17



45.52.19

Gaumenplatte
Palate plate
Placa paladinal
Plaque palatine
Placca palatina

**45.52.02
Davis-Mayer**

komplett, bestehend aus:
complete, consisting of:
completo, compuesto de:
complet, se composant de:
completo, composto da:

1	Rahmen Frame Bastidor Cadre Telaio	1 × 45.52.22
7	Zungendrücker Tongue depressors Bajalenguas Abaisse-langues Abbassalingua	1 × 45.52.11 1 × 45.52.12 1 × 45.52.13 1 × 45.52.14 1 × 45.52.15 1 × 45.52.16 1 × 45.52.17

904.50.41

Ersatz-Silikoneinlage für Gebissplatten
Spare silicone insert for bite plate
Plantilla de silicona de repuesto para placas de dentadura
Plaque de rechange en silicone pour plaques à denture
Piastra di ricambio in silicone per placche dentarie



TREVALLi

Mundsperrer
Mouth Gag
Abreboca
Ouvre-bouche
Apribocca



45.53.20

Rahmen allein
Frame only
Bastidor solo
Cadre seul
Telaio solo

Mclvor



1
23 × 70 mm
45.53.11

2
25 × 86 mm
45.53.12

3
26 × 100 mm
45.53.13

45.53.00
Mclvor

komplett, bestehend aus:
complete, consisting of:
completo, compuesto de:
complet, se composant de:
completo, composto da:

1	Rahmen Frame Bastidor Cadre Telaio	1 × 45.53.20
3	Zungendrucker Tongue depressors Bajalenguas Abaisse-langues Abbassalingua	1 × 45.53.11 1 × 45.53.12 1 × 45.53.13



TREVALLi

**Mundsperrer
Mouth Gags
Abrebocas
Ouvre-bouches
Apribocca**



45.52.31

Rahmen allein
Frame only
Bastidor solo
Cadre seul
Telaio solo



1
55 x 25 mm
72.08.11

2
60 x 27 mm
72.08.12

3
70 x 30 mm
72.08.13



65 x 28 mm
45.57.11

**45.52.30
Köln**

komplett, bestehend aus:
complete, consisting of:
completo, compuesto de:
complet, se composant de:
completo, composto da:

1	Rahmen Frame Bastidor Cadre Telaio	1x 45.52.31
4	Zungendrücker Tongue depressors Bajalenguas Abaisse-langues Abbassalingua	1x 45.57.11 1x 72.08.11 1x 72.08.12 1x 72.08.13



TREVALLi

Mundsperrer
Mouth Gag
Abreboca
Ouvre-bouche
Apribocca



45.57.22

Rahmen allein
Frame only
Bastidor solo
Cadre seul
Telaio solo

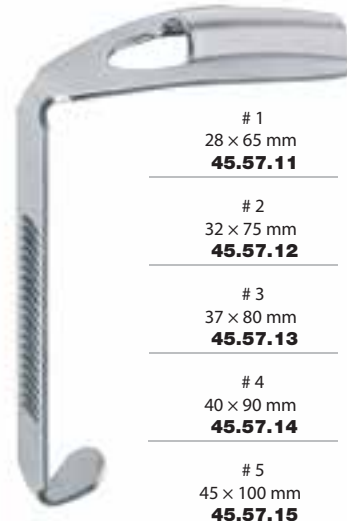

1
28 × 65 mm
45.57.11 ①

2
32 × 75 mm
45.57.12 ②

3
37 × 80 mm
45.57.13 ③

4
40 × 90 mm
45.57.14

5
45 × 100 mm
45.57.15

Kilner-Doughty

45.57.02
Kilner-Doughty

komplett, bestehend aus:
complete, consisting of:
completo, compuesto de:
complet, se composant de:
completo, composto da:

1	Rahmen Frame Bastidor Cadre Telaio	1 × 45.57.22
3	Zungendrücker Tongue depressors	1 × 45.57.11 ①
	Bajalenguas	1 × 45.57.12 ②
	Abaisse-langues Abbassalingua	1 × 45.57.13 ③
1	Gaumenplatte Palate plate Placa palatinal Plaque palatine Placca palatina	1 × 45.57.19



45.57.19

Gaumenplatte
Palate plate
Placa palatinal
Plaque palatine
Placca palatina

45.59.90

Bruststütze für alle Mundsperrer
Chest support for all mouth gags
Soporte de pecho para todos los abre bocas
Support de poitrine pour tous les ouvre-bouches
Supporto sternale per tutti gli apribocca



Negus



TREVALLi

Tonsillennmesser, Tonsillenschraube
Tonsil Knives, Tonsil Screw
Bisturías para amígdalas, Tornillo para amígdalas
Bistouris à amygdales, Vis à amygdales
Bisturi per tonsille, Vite per tonsille

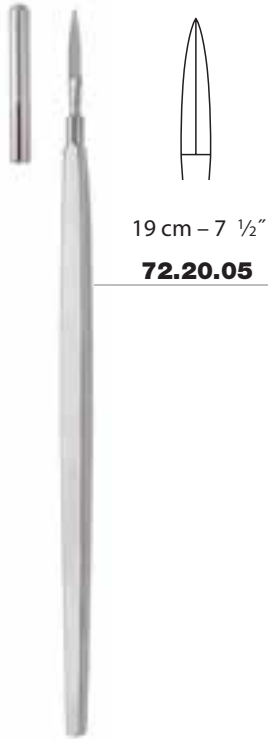

19 cm – 7 1/2"

72.20.05



21 cm – 8 1/4"

72.20.35

Abraham



Ø 7 mm

20 cm – 8"

72.20.85



23 cm – 9"

72.20.40

Brünings

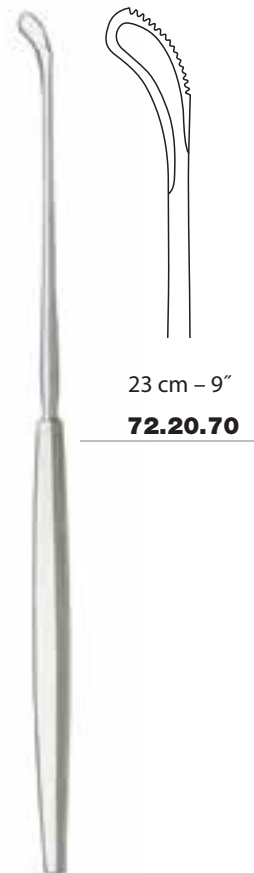

23 cm – 9"

72.20.70

Fisher



TREVALLi

Tonsillendissektoren, Speichelgangsonde
Tonsil Dissectors, Salivary Duct Probe
Disectores para amígdalas, Sonda para canal de saliva
Dissecteurs à amygdales, Sonde pour conduit salivaire
Dissettori tonsillari, Sonda per canale salivale



22 cm - 8 3/4"

72.25.15

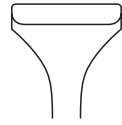

22 cm - 8 3/4"

72.25.20



22 cm - 8 3/4"

72.25.30

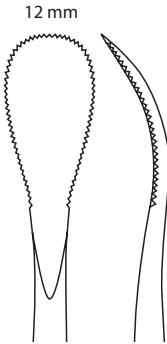

12 mm

24 cm - 9 1/2"

72.25.35

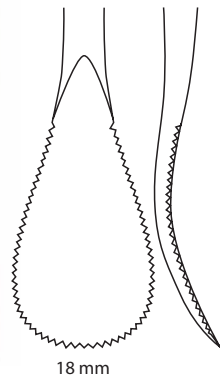

18 mm

Henke



6 mm

Hurd



10 mm

Alderdice

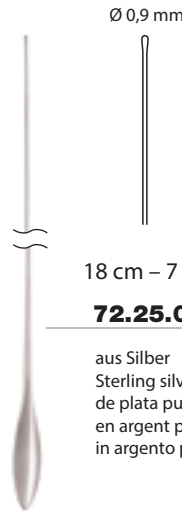

Ø 0,9 mm

18 cm - 7 1/8"

72.25.01

aus Silber
Sterling silver
de plata pura
en argent pur
in argento puro

Seiffert



TREVALLi

Tonsillendissektoren
Tonsil Dissectors
Disectores para amígdalas
Dissecteurs à amygdales
Dissettori tonsillari

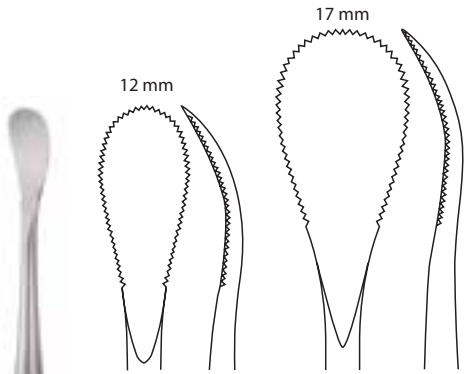

24 cm - 9 1/2"

72.25.37

24 cm - 9 1/2"

72.25.38

Henke

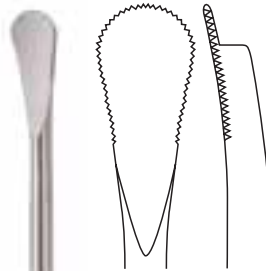

23 cm - 9"

72.25.40

mit Absaugvorrichtung
with suction device
con aspiración
avec aspiration
con aspiratore

Lopez-Reinke

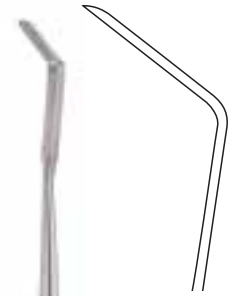

27 cm - 10 3/4"

72.25.45

Enukleator
Enucleator
Enucleador
Enucléateur
Enucleatore

Carpenter





TREVALLi

Tonsillentamponstopfer, Tonsillenfasspinzette, Tonsillenklemme
Tonsil Gauze Packer, Tonsil Seizing Forceps, Tonsil Forceps
Tamponador tonsilar, Pinza prensora de amígdalas, Pinza-clamp de amígdalas
Tamponneur à amygdales, Pince pour saisir amygdales, Pince-clamp amygdales
Tamponatore tonsillare, Pinza da presa per tonsille, Pinza per tonsille

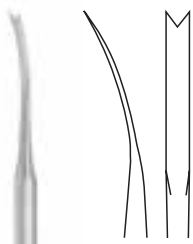

18 cm – 7 1/8"

330.01.80

scharf
sharp
cortante
tranchant
tagliente



Luniatschek



22 cm – 8 3/4"

72.40.05



Marschik



18 cm – 7 1/8"

72.40.15

Mikulicz



TREVALLi

Tonsillenfasszangen
Tonsil Seizing Forceps
Pinzas prensora de amígdalas
Pinces pour saisir amygdales
Pinze da presa tonsillari



18 cm - 7 1/8"

72.40.18

White



19 cm - 7 1/2"

72.40.19

Colver



20 cm - 8"

72.40.20

Marschik-Krone



21 cm - 8 1/4"

72.40.21

Blohmke



TREVALLi

Tonsillenfasszangen/-abszeßzange
Tonsil Seizing/-Abscess Forceps
Pinzas prensoras/ Pinza para abscesos en amígdalas
Pinces pour saisir/ pince pour abcès amygdales
Pinze da presa/ pinza per accessi tonsillari



20,5 cm - 8"

72.40.22



23 cm - 9"

72.40.23

Abraham



21 cm - 8 1/4"

72.40.50

Tyding



20 cm - 8"

72.40.90

Thilenius

White



TREVALLi

**Tonsillenklemmen
Tonsil Forceps
Pinza-clamp de amígdalas
Pincas amygdales
Pinze per tonsille**



19 cm - 7 1/2"

72.42.21

1

Negus

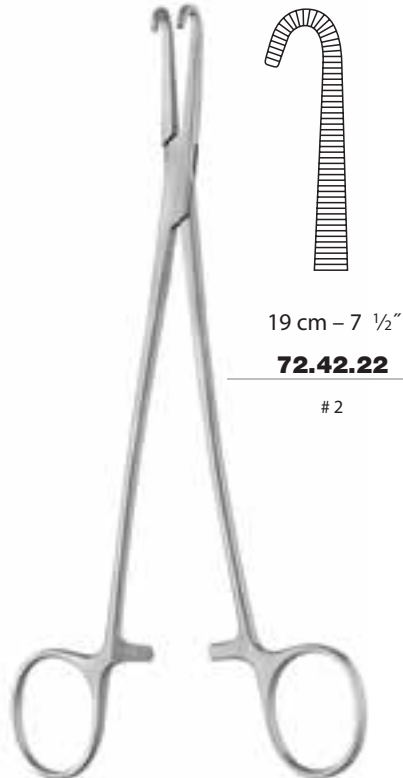

19 cm - 7 1/2"

72.42.22

2

Negus



18,5 cm - 7 1/4"

72.42.90

McWorther-Lothrop

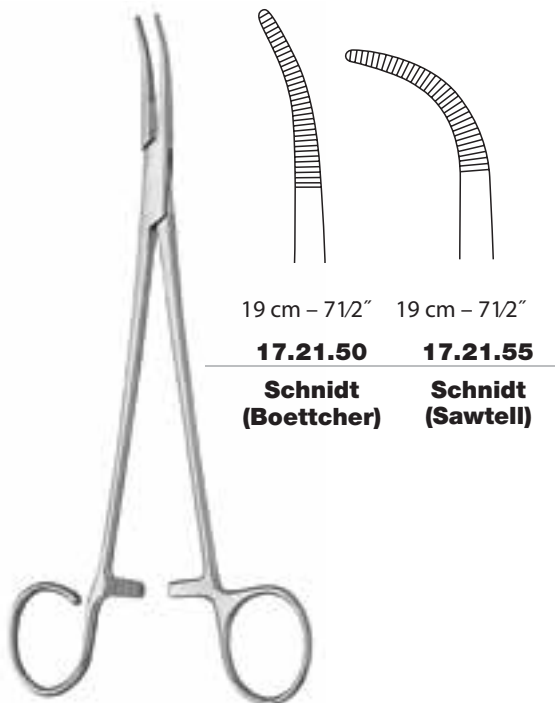

19 cm - 7 1/2"

17.21.50
Schnidt
(Boettcher)

19 cm - 7 1/2"

17.21.55
Schnidt
(Sawtell)

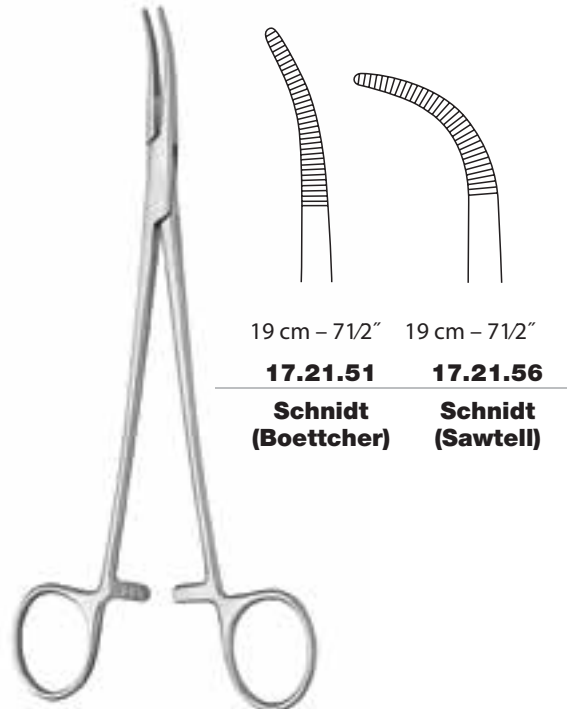

19 cm - 7 1/2"

17.21.51
Schnidt
(Boettcher)

19 cm - 7 1/2"

17.21.56
Schnidt
(Sawtell)



TREVALLi

**Tonsillenscheren
Tonsil Scissors
Tijeras para amígdalas
Ciseaux à amygdales
Forbici per tonsille**

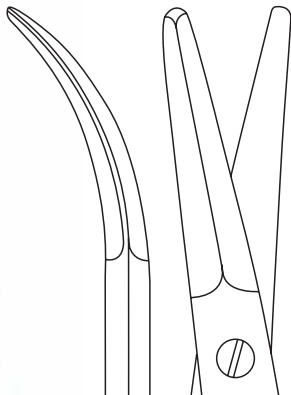

18 cm - 7 1/8"

72.45.20 standard

Prince

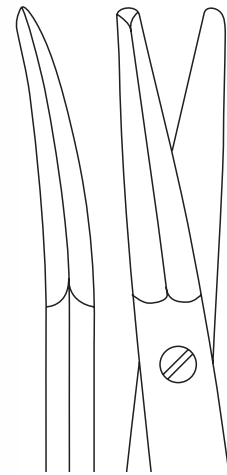

18 cm - 7 1/8"

72.45.25 standard

Boettcher

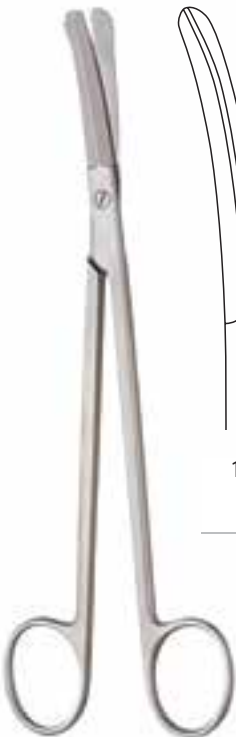

19 cm - 7 1/2"

72.45.30 standard

Good



Gezahnte Schneiden
Serrated cutting edges
Hojas dentadas
Lames dentelées
Lame dentellate

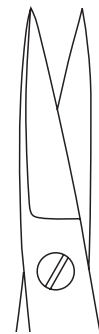
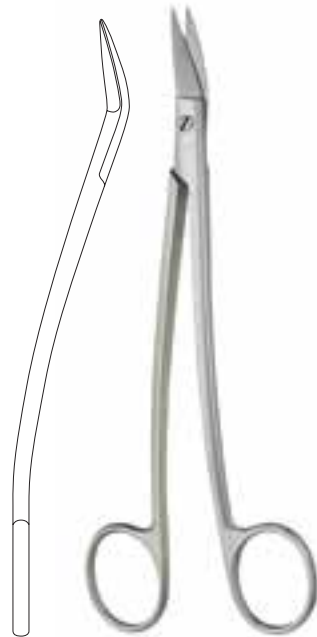

17 cm - 6 3/4"

72.45.50 standard

272.45.50 supercut

282.45.50 black line

Dean



TREVALLI

Tonsillenschnürer
Tonsil Snares
Amigdalótomos
Serre-nœuds amygdaliens
Serranodi per tonsille

Lieferung mit 3 Drahtschlingen
Delivery with 3 wire loops
Suministro con 3 lazos de alambre
La livraison comprend 3 anses en fil
Consegna con 3 anse di filo

Lieferung mit 3 vorgeformten Schnürerdrähten
Delivery with 3 preshaped snare wires
Suministro con 3 alambres para cierranudos, preformados
La livraison comprend 3 fils pour serre-nœud, pré coupés
Consegna con 3 fili per serranodi, preformati



29 cm – 11 $\frac{3}{8}$ "

72.50.05

mit Sperre
with catch
con cremallera
avec crémaillère
con cremagliera

Brünings



27 cm – 10 $\frac{3}{4}$ "

72.50.10

Eves



27 cm – 10 $\frac{3}{4}$ "

72.50.11

mit Sperre
with catch
con cremallera
avec crémaillère
con cremagliera

Eves



TREVALLI

**Tonsillenschnürer
Tonsil Snares
Amigdalótomos
Serre-noeuds amygdaliens
Serranodi per tonsille**

Tonsillenschnürer mit geradem Aufsatz
Tonsil snare with straight tip
Amigdalótomos con terminal recto
Serre-noeud amygdaliens avec embout droit
Serranodo per tonsille con terminale retto



Lieferung mit 3 vorgeformten Schnürerdrähten
Delivery with 3 preshaped snare wires
Suministro con 3 alambres para cierranudos, preformados
La livraison comprend 3 fils pour serre-noeud, précoupés
Consegna con 3 fili per serranodi, preformati

72.50.51



Tyding

27 cm – 10 3/4"

72.50.25

für Kunststoff-Faden
for synthetic stitch
para hilo sintético
pour fibre synthétique
per filo di plastica



Roeder Mod. E



72.50.53

gerader Aufsatz allein
straight tip only
Terminal recto solo
Embout droit seul
Terminale retto solo



TREVALLi



Rolle zu 10 m
Coil 10 m (33.3 ft.)
Rollo de 10 m
Rouleau de 10 m
Rotolo da 10 m

Ø 0,35 mm	Ø 0,40 mm	Ø 0,45 mm
66.15.43	66.15.44	66.15.45

Standardgröße
Standard size
Espesor estándar
Epaisseur standard
Spessore standard



für Tonsillenschnürer:
for tonsil snares:
para amigdalótomos de amígdalas:
pour serre-nœud amygdaliens:
per serranodi per tonsille:



Schnürerdrähte, Drahtschlingen
Snare Wires, Wire Loops
Alambres para amigdalótomos, Lazos de alambre
Fils pour serre-nœud, Anses en fil
Fili per serranodi, Anse di filo

Schnürerdrähte
Snare wires
Alambres para amigdalótomos
Fils pour serre-nœud
Fili per serranodi

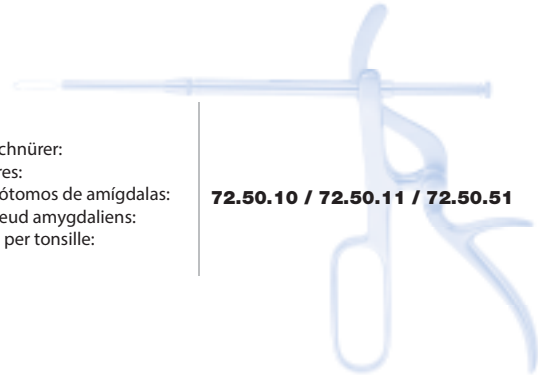

72.50.10 / 72.50.11 / 72.50.51



Ø 0,35 mm	Ø 0,40 mm	Ø 0,45 mm	Ø 0,50 mm
72.50.96	72.50.97	72.50.98	72.50.99



Standardgröße
Standard size
Espesor estándar
Epaisseur standard
Spessore standard

Schnürerdrähte, vorgeformt
Snare wires, preshaped
Alambres para amigdalótomos, preformados
Fils pour serre-nœud, pré coupés
Fili per serranodi, preformati

Ø 0,4 mm

72.50.95



Drahtschlingen, gelötet
Wire loops, soldered
Lazos de alambre, soldados
Anses en fil, soudées
Anse di filo, saldati

für Tonsillenschnürer:
for tonsil snares:
para amigdalótomos de amígdalas:
pour serre-nœud amygdaliens:
per serranodi per tonsille:

72.50.05

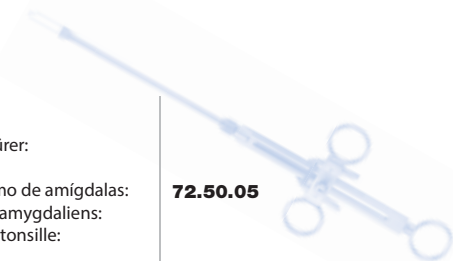

Verpackungseinheit "X" Stück
Packing unit "X" pieces
Paquete de "X" unidades
Emballage de "X" pièces
Confezione da "X" pezzi



TREVALLi

**Tonsillotom
Tonsillectome
Amigdalótomo
Amygdalotome
Tonsillotomo**

bestehend aus:	1 Griff und je 1 Aufsatz Fig. 1-3
consisting of:	1 handle and 1 blade each fig. 1-3
ompuesto de:	1 mango y 1 cuchillo de cada una de las fig. 1-3
se composant de:	1 manche et 1 embout de chaque des fig. 1-3
omposto da:	1 manico e 1 lame di ogni fig. 1-3

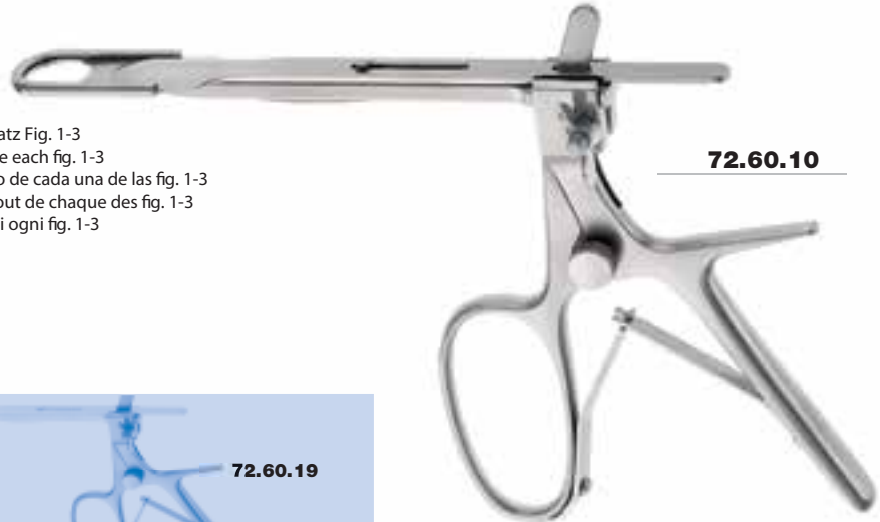

72.60.10

Sluder-Ballenger

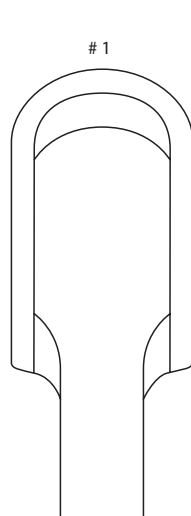

18 mm

72.60.21

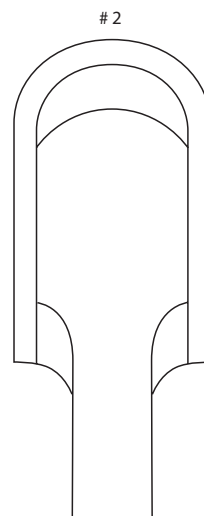

20 mm

72.60.22

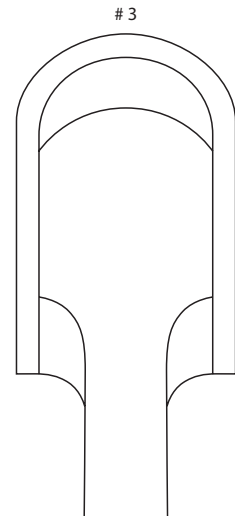

23 mm

72.60.23

Sluder-Ballenger



TREVALLi

Tonsillenzangen
Tonsil Punches
Pinzas para amígdalas
Pinces amygdaliennes
Pinze tonsillari

12 cm - 4 3/4"



scharf
sharp
cortante
tranchant
tagliente



Ø 13 mm

72.65.13



Ø 15 mm

72.65.15

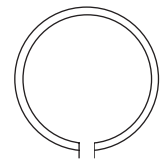

Ø 17 mm

72.65.17

Hartmann



TREVALLi

**Tonsillenkanülen, Spritzen
Tonsil Cannulas, Syringes
Cánulas tonsilares, Jeringas
Canules amygdaliennes, Seringues
Cannule tonsillari, Siringhe**

Ø 0,8 mm



Luer-Lock



12 cm - 4 3/4"

72.95.10



45°

12 cm - 4 3/4"

72.95.14



90°

12 cm - 4 3/4"

72.95.19

Luer-Lock

2 ml

09.78.52

5 ml

09.78.53

09.78.54

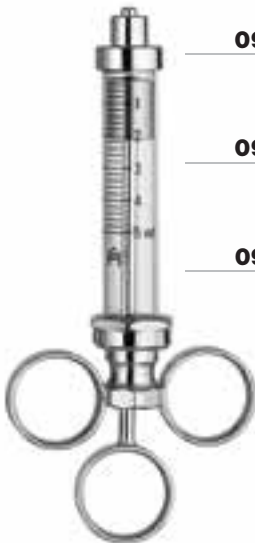

Luer-Lock

1 ml

09.78.31

2 ml

09.78.32

5 ml

09.78.33

10 ml

09.78.34



Luer-Lock

1 ml

09.78.41

2 ml

09.78.42

5 ml

09.78.43

10 ml

09.78.44



Ersatzzylinder
Spare barrels
Cilindros de repuesto
Cylindres de rechange
Cilindri di ricambio



TREVALLi

ENT INSTRUMENTS

Laryngoskopie · Bronchoskopie
Laryngology · Bronchoscopy
Laringoscopía · Broncoscopía
Laryngoscopie · Bronchoscopie
Laringoscopia · Broncoscopia

trevalli@mweb.co.za



TREVALLI

Laryngo-Bronchoskopiezangen
Laryngeal and Bronchoscopic Forceps
Pinzas laringo-broncoscópicas
Pinces laryngo-bronchoscopiques
Pinze per laringo-broncoscopia



schlankes Modell
 delicate model
 modelo delicado
 modèle élancé
 modello delicato

	a	28 cm – 11"	35 cm – 13 3/4"	
	73.11.04	73.12.04		
	73.11.12	73.12.12	Ø 2 mm	
	73.11.17	73.12.17	Ø 2 mm	



Jackson

	a	28 cm – 11"	35 cm – 13 3/4"	
	73.11.20	73.12.20		Patterson
	73.11.31	73.12.31		
	73.11.35	73.12.35		



Biopsiezange, fein
 Biopsy forceps, delicate
 Pinza para biopsia, fina
 Pince à biopsie, fine
 Pinza per biopsia, fina

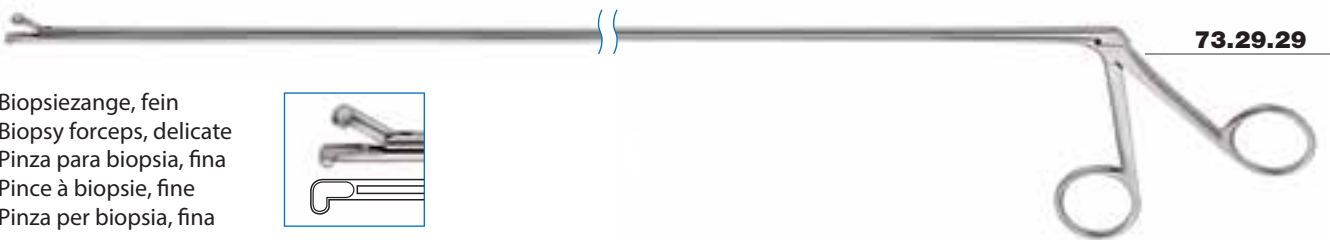

Mayerson



TREVALLi

Broncho-Oesophagoskopiezangen
Bronchial-Esophageal Forceps
Pinzas bronco-esofagoscópicas
Pinces broncho-oesophagiennes
Pinze per bronco-esofagoscopia

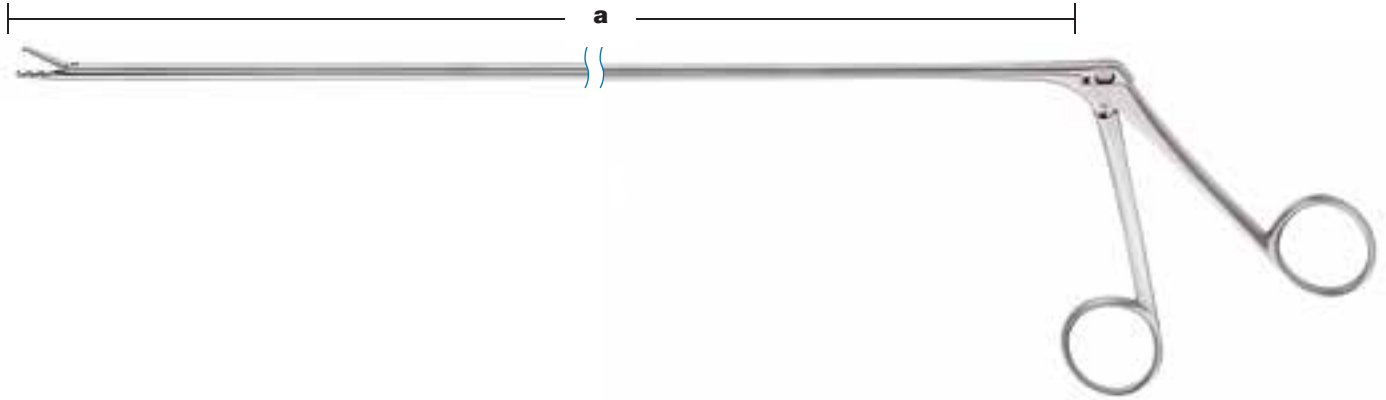

Jackson

	a	30 cm – 11 3/4"	40 cm – 15 3/4"	50 cm – 19 3/4"	60 cm – 23 3/4"	
	73.13.04	73.14.04	73.15.04	73.16.04		
	73.13.05	73.14.05	73.15.05	73.16.05		
	73.13.06	73.14.06	73.15.06	73.16.06		
	73.13.12	73.14.12	73.15.12	73.16.12	Ø 2 mm	
	73.13.14	73.14.14	73.15.14	73.16.14	Ø 4 mm	
	73.13.17	73.14.17	73.15.17	73.16.17	Ø 2 mm	
	73.13.19	73.14.19	73.15.19	73.16.19	Ø 4 mm	
	73.13.20	73.14.20	73.15.20	73.16.20	Patterson	
	73.13.31	73.14.31	73.15.31	73.16.31		
	73.13.35	73.14.35	73.15.35	73.16.35		



TREVALLi

Broncho-Oesophagoskopiezangen
Bronchial-Esophageal Forceps
Pinzas bronco-esofagoscópicas
Pinces broncho-oesophagiennes
Pinze per bronco-esofagoscopia

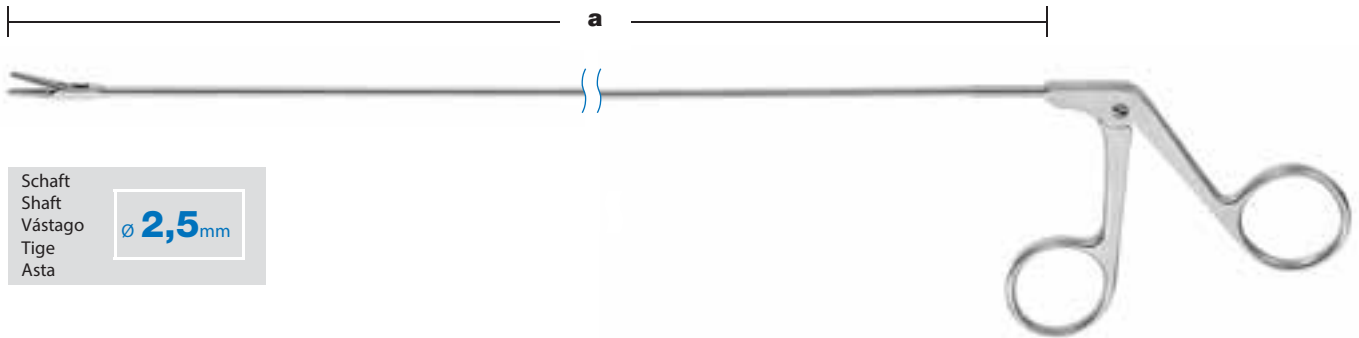

Schaft
 Shaft
 Vástago
 Tige
 Asta

Ø **2,5**mm

	a	40 cm – 15 3/4"	50 cm – 19 3/4"	60 cm – 23 3/4"	
	73.19.00	73.20.00	73.21.00		
	73.19.01	73.20.01	73.21.01		
	73.19.02	73.20.02	73.21.02		
	73.19.03	73.20.03	73.21.03		
	73.19.04	73.20.04	73.21.04		
	73.19.05	73.20.05	73.21.05		
	73.19.06	73.20.06	73.21.06		

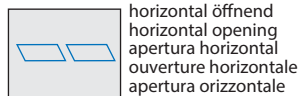
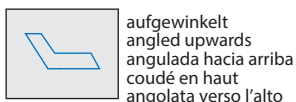
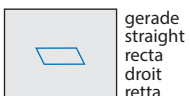



TREVALLi

Broncho-Oesophagoskopiezangen
Bronchial-Esophageal Forceps
Pinzas bronco-esofagoscópicas
Pinces broncho-oesophagiennes
Pinze per bronco-esofagoscopia

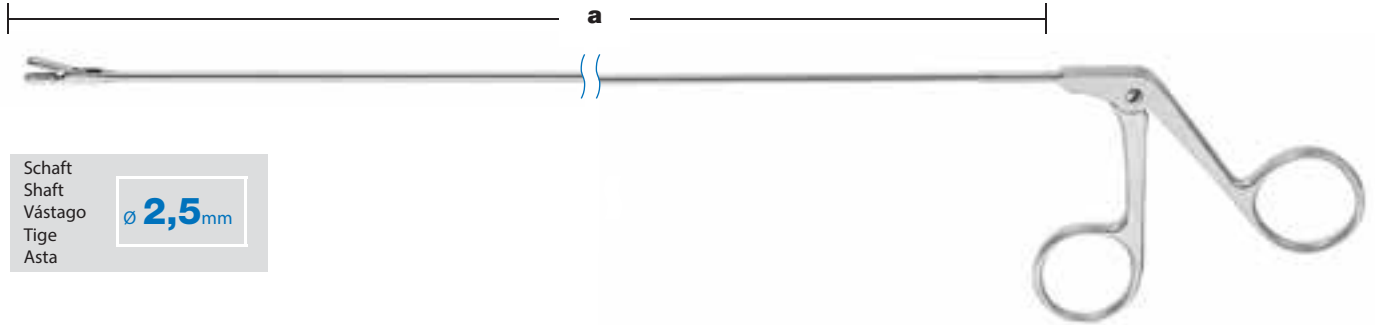

Schaft
 Shaft
 Vástago
 Tige
 Asta

Ø **2,5**mm

	a	40 cm – 15 3/4"	50 cm – 19 3/4"	60 cm – 23 3/4"	
	73.19.07	73.20.07	73.21.07		rechts gebogen curved right curva derecha courbé à droite curva a destro
	73.19.08	73.20.08	73.21.08		links gebogen curved left curva izquierda courbé à gauche curva a sinistro
	73.19.09	73.20.09	73.21.09		
	73.19.10	73.20.10	73.21.10		
	73.19.11	73.20.11	73.21.11		
	73.19.12	73.20.12	73.21.12		



TREVALLi

Laryngo- und Kinder-Bronchoskopiezangen
Laryngeal and Pediatric Bronchoscopy Forceps
Pinzas laringo y bronoscópicas para niños
Pinces laryngo et bronoscopiques pour enfants
Pinze per laringo e bronoscopia per bambini

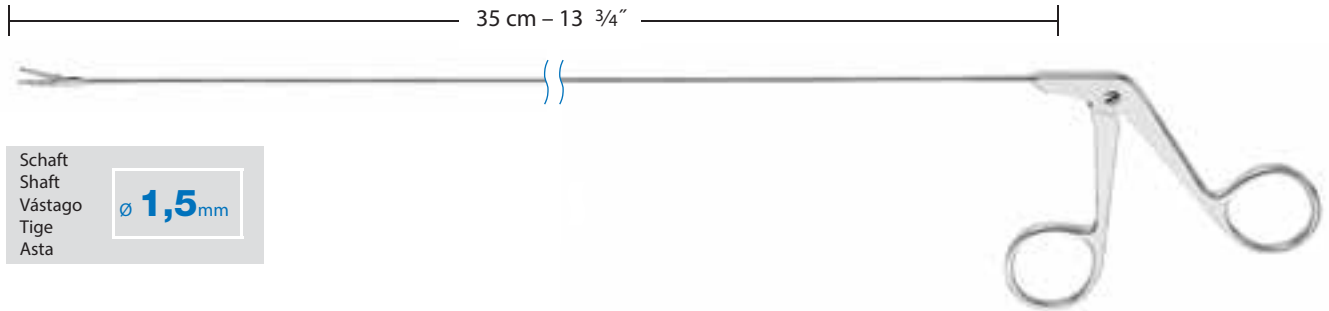

	73.22.00			73.22.06	rechts gebogen curved right curva derecho courbé à droite curva a destro
	73.22.01			73.22.07	links gebogen curved left curva izquierdo courbé à gauche curva a sinistro
	73.22.02			73.22.08	
	73.22.03			73.22.09	
	73.22.04			73.22.10	
	73.22.05				

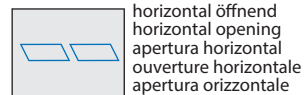
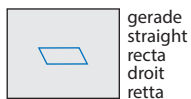



TREVALLi

**Bronchoskopiezangen
Bronchoscopy Forceps
Pinzas bronoscópicas
Pinces bronoscopiques
Pinze per bronoscopia**

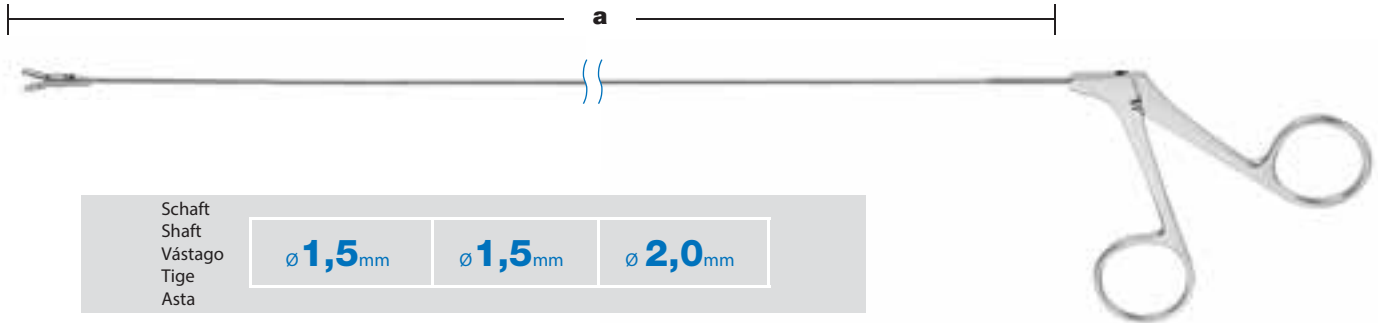

Schaft Shaft Vástago Tige Asta	Ø 1,5 mm	Ø 1,5 mm	Ø 2,0 mm
--	-----------------	-----------------	-----------------

	a	25 cm – 10"	35 cm – 13 ¾"	35 cm – 13 ¾"	
	73.22.30	73.22.31	73.22.32		
	73.22.40	73.22.41	73.22.42		
	73.22.50	73.22.51	73.22.52		
	73.22.60	73.22.61	73.22.62		

Schaft Shaft Vástago Tige Asta	Ø 2,5 mm
--	-----------------

	a	55 cm – 21 ¾"	
	73.22.33		
	73.22.43		
	73.22.53		
	73.22.63		



TREVALLi

Endolaryngeale Mikrochirurgie
Endolaryngeal Micro Surgery
Microcirugía endolaríngea
Microchirurgie endolaryngienne
Microchirurgia endolaríngea

23 cm – 9"

konisch zulaufender Schaft
 conical shaft
 vástago cónico
 tige conique
 asta conica

Ø 2,0-3,0 mm



	Ø 2 mm	Ø 4 mm	
	 73.17.01	 73.17.10	gerade straight recta droit retta
	 73.17.02	 73.17.11	aufgewinkelt angled upwards angulada hacia arriba coudé en haut angolata verso l'alto
	 73.17.03	 73.17.12	rechts gebogen curved right curva derecha courbé à droite curva a destro
	 73.17.04	 73.17.13	links gebogen curved left curva izquierda courbé à gauche curva a sinistro
	 73.17.05		rechts aufgebogen curved right upwards curva derecha hacia arriba courbé à droite en haut curva destro verso l'alto
	 73.17.06		links aufgebogen curved left upwards curva izquierda hacia arriba courbé à gauche en haut curva sinistro verso l'alto
	 73.17.07		rechts gebogen, horizontal öffnend curved right, horizontal opening curva derecha, apertura horizontal courbé à droite, ouverture horizontale curva a destro, apertura orizzontale
	 73.17.08		links gebogen, horizontal öffnend curved left, horizontal opening curva izquierda, apertura horizontal courbées à gauche, ouverture horizontale curva a sinistro, apertura orizzontale
	 73.17.09		gerade straight recta droit retta
	 73.17.16		aufgewinkelt angled upwards angulada hacia arriba coudées en haut angolata verso l'alto
	 73.17.17		aufgebogen, rechts öffnend curved upwards, right opening curva hacia arriba, apertura derecha courbées en haut, ouverture à droite curva verso l'alto, apertura destro
	 73.17.18		aufgebogen, links öffnend curved upwards, left opening curva hacia arriba, apertura izquierda courbées en haut, ouverture à gauche curva verso l'alto, apertura sinistra



TREVALLi

Endolaryngeale Mikrochirurgie
Endolaryngeal Micro Surgery
Microcirugia endolaringeal
Microchirurgie endolaryngienne
Microchirurgia endolaringeale

23 cm – 9"

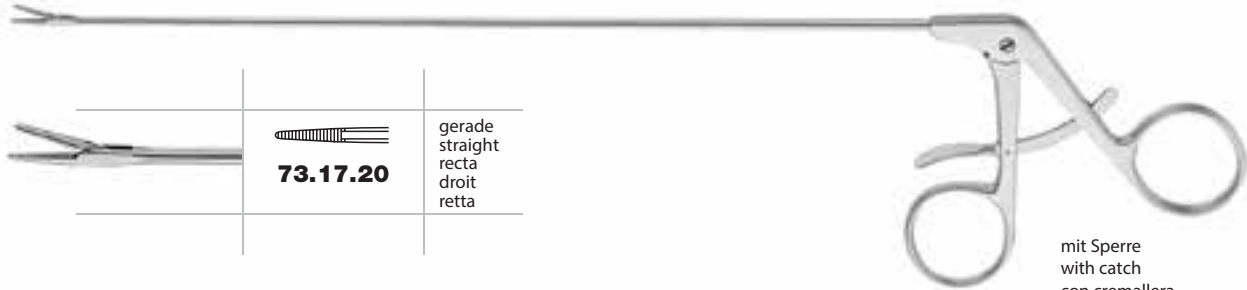

	73.17.20	gerade straight recta droit retta
--	-----------------	---

mit Sperre
with catch
con cremallera
avec crémaillère
con cremagliera

konisch zulaufender Schaft
conical shaft
vástago cónico
tige conique
asta conica

Ø 2,0-3,0mm

23 cm – 9"

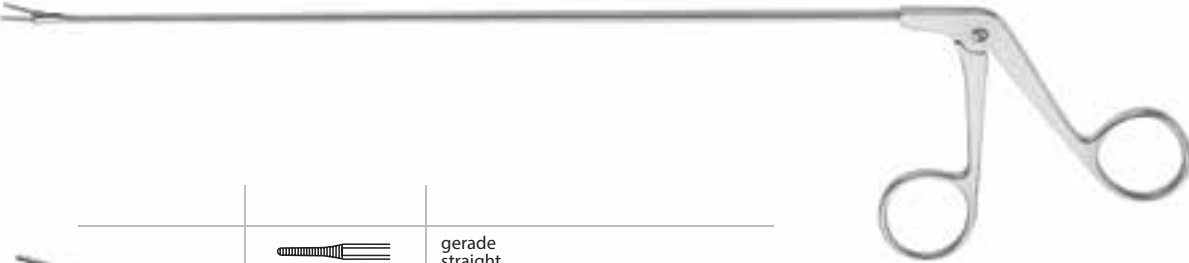

	73.17.21	gerade straight recta droit retta
	73.17.24	gerade, horizontal öffnend straight, horizontal opening recta, apertura horizontal droit, ouverture horizontale retta, apertura orizzontale
	73.17.22	rechts gebogen curved right curva derecha courbé à droite curva a destro
	73.17.23	links gebogen curved left curva izquierda courbé à gauche curva a sinistro
	73.17.25	aufgewinkelt angled upwards angulada hacia arriba coudé en haut angolata verso l'alto
	73.17.26	aufgebogen, horizontal öffnend curved upwards, horizontal opening curva hacia arriba, apertura horizontal courbé en haut, ouverture horizontale curva verso l'alto, apertura orizzontale



TREVALLi

Endolaryngeale Mikrochirurgie
Endolaryngeal Micro Surgery
Microcirugía endolaríngeal
Microchirurgie endolaryngienne
Microchirurgia endolaríngeale

23 cm – 9"

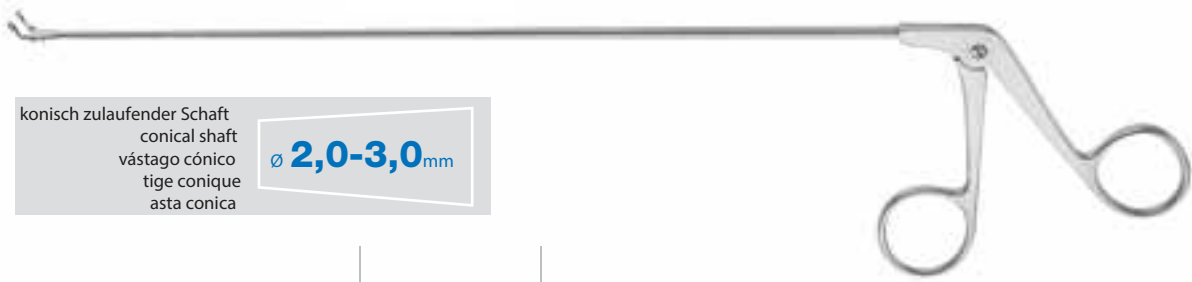

konisch zulaufender Schaft
 conical shaft
 vástago cónico
 tige conique
 asta conica

∅ 2,0-3,0_{mm}

		aufgebogen, rechts öffnend curved upwards, right opening curva hacia arriba, apertura derecha courbé en haut, ouverture à droite curva verso l'alto, apertura destra
		aufgebogen, links öffnend curved upwards, left opening curva hacia arriba, apertura izquierda courbé en haut, ouverture à gauche curva verso l'alto, apertura sinistrae
		gerade straight recta droit retta
		aufgewinkelt angled upwards angulada hacia arriba coudé en haut angolata verso l'alto

23 cm – 9"



konisch zulaufender Schaft
 conical shaft
 vástago cónico
 tige conique
 asta conica

∅ 2,0-3,0_{mm}

Stimmbandhaltezaugen
 Vocal cord holding forceps
 Pinzas para agarrar cuerdas vocales
 Pinces à fixer les cordes vocales
 Pinze per tenere le corde vocali

Arnold

		rechts gebogen curved right curva derecha courbé à droite curva a destro
		links gebogen curved left curva izquierda courbé à gauche curva a sinistro



TREVALLi

Endolaryngeale Mikrochirurgie
Endolaryngeal Micro Surgery
Microcirugía endolaringeal
Microchirurgie endolaryngienne
Microchirurgia endolaringeale

23 cm – 9"

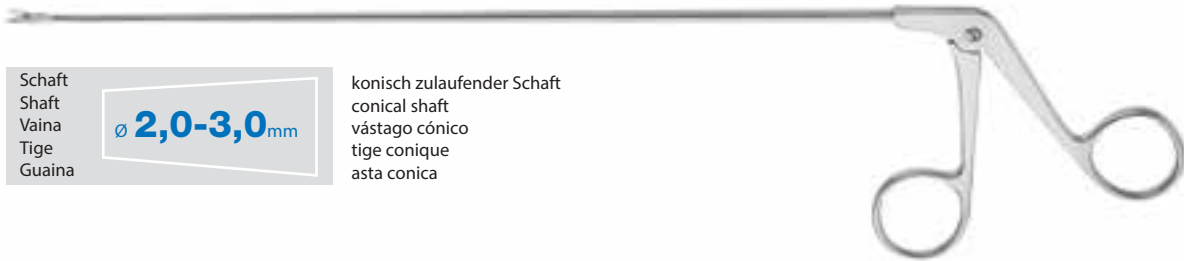

Schaft
Shaft
Vaina
Tige
Guaina

Ø **2,0-3,0**mm

konisch zulaufender Schaft
conical shaft
vástago cónico
tige conique
asta conica

	 73.17.34	gerade, horizontal schneidend straight, horizontal cutting recta, corte horizontal droit, à coupe horizontale retta, taglio orizzontale
	 73.17.35	gerade straight recta droit retta
	 73.17.36	aufgewinkelt angled upwards angulada hacia arriba coudé en haut angolata verso l'alto
	 73.17.37	aufgewinkelt angled upwards angulada hacia arriba coudé en haut angolata verso l'alto
	 73.17.38	rechts gebogen curved right curva derecha courbé à droite curva a destro
	 73.17.33	links gebogen curved left curva izquierda courbé à gauche curva a sinistro



TREVALLi

Endolaryngeale Mikrochirurgie
Endolaryngeal Micro Surgery
Microcirugia endolaringeal
Microchirurgie endolaryngienne
Microchirurgia endolaringeale

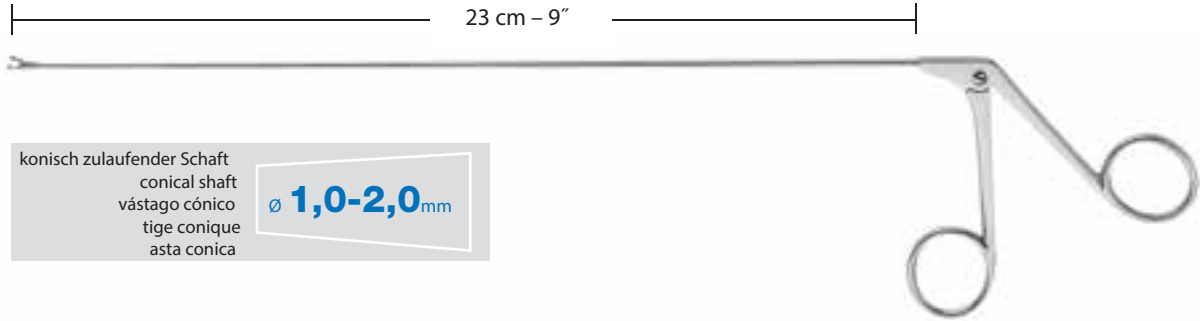

konisch zulaufender Schaft
 conical shaft
 vástago cónico
 tige conique
 asta conica

Ø 1,0-2,0mm

	Ø 1 mm	
	 73.17.40	gerade straight recta droit retta
	 73.17.41	aufgebogen curved upwards curva hacia arriba courbé en haut curva verso l'alto
	 73.17.42	rechts gebogen curved right curva derecha courbé à droite curva a destro
	 73.17.43	links gebogen curved left curva izquierda courbé à gauche curva a sinistro
	 73.17.44	aufgebogen, 45° rechts curved upwards, 45° right curva hacia arriba, 45° derecha courbé en haut, 45° à droite curva verso l'alto, 45° destro
	 73.17.45	aufgebogen, 45° links curved upwards, 45° left curva hacia arriba, 45° izquierda courbé en haut, 45° à gauche curva verso l'alto, 45° sinistro



TREVALLi

Endolaryngeale Mikrochirurgie
Endolaryngeal Micro Surgery
Microcirugía endolaríngica
Microchirurgie endolaryngienne
Microchirurgia endolaríngica

23 cm – 9"

		gerade straight recta droit retta
		aufgebogen curved upwards curva hacia arriba courbé en haut curva verso l'alto
		rechts gebogen curved right curva derecha courbé à droite curva a destro
		links gebogen curved left curva izquierda courbé à gauche curva a sinistro
		aufgebogen, 45° rechts curved upwards, 45° right curva hacia arriba, 45° derecha courbé en haut, 45° à droite curva verso l'alto, 45° destro
		aufgebogen, 45° links curved upwards, 45° left curva hacia arriba, 45° izquierda courbé en haut, 45° à gauche curva verso l'alto, 45° sinistro

konisch zulaufender Schaft
 conical shaft
 vástago cónico
 tige conique
 asta conica

∅ 1,0-2,0 mm

23 cm – 9"

		gerade straight recta droit retta
		aufgebogen curved upwards curva hacia arriba courbé en haut curva verso l'alto
		rechts gebogen curved right curva derecha courbé à droite curva a destro
		links gebogen curved left curva izquierda courbé à gauche curva a sinistro



TREVALLi

Endolaryngeale Mikrochirurgie
Endolaryngeal Micro Surgery
Microcirugia endolaringeal
Microchirurgie endolaryngienne
Microchirurgia endolaringeale

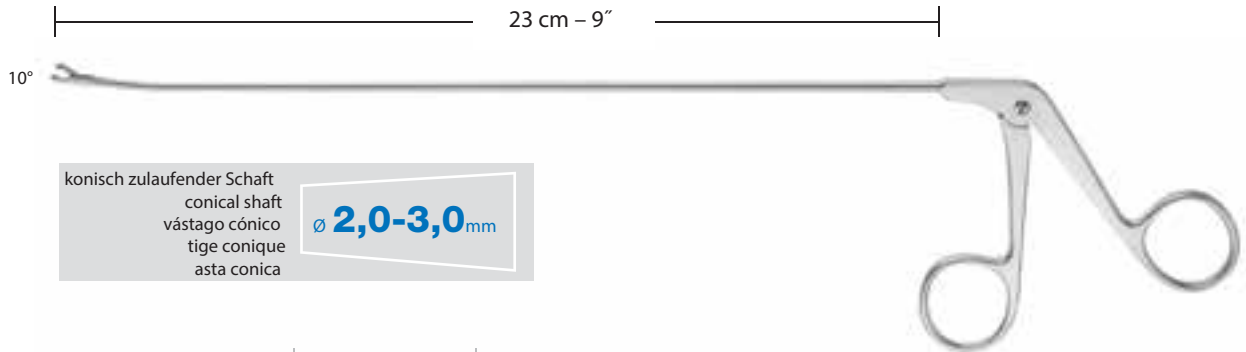

konisch zulaufender Schaft
 conical shaft
 vástago cónico
 tige conique
 asta conica

Ø **2,0-3,0mm**

	Ø 2 mm 73.17.70	gerade straight recta droit retta
	 73.17.71	aufgebogen curved upwards curva hacia arriba courbé en haut curva verso l'alto
	 73.17.72	rechts gebogen curved right curva derecha courbé à droite curva a destro
	 73.17.73	links gebogen curved left curva izquierda courbé à gauche curva a sinistro
	 73.17.74	gerade straight recta droit retta
	 73.17.75	aufgebogen curved upwards curva hacia arriba courbé en haut curva verso l'alto
	 73.17.76	rechts gebogen curved right curva derecha courbé à droite curva a destro
	 73.17.77	links gebogen curved left curva izquierda courbé à gauche curva a sinistro



TREVALLi

Endolaryngeale Mikrochirurgie
Endolaryngeal Micro Surgery
Microcirugía endolaringeal
Microchirurgie endolaryngienne
Microchirurgia endolaringeale

Laryngoskopiezangen für Kinder
 Laryngoscopy forceps for children
 Pinzas laringoscópicas para niños
 Pinces laryngoscopiques pour enfants
 Pinze per laryngoscopia per bambini

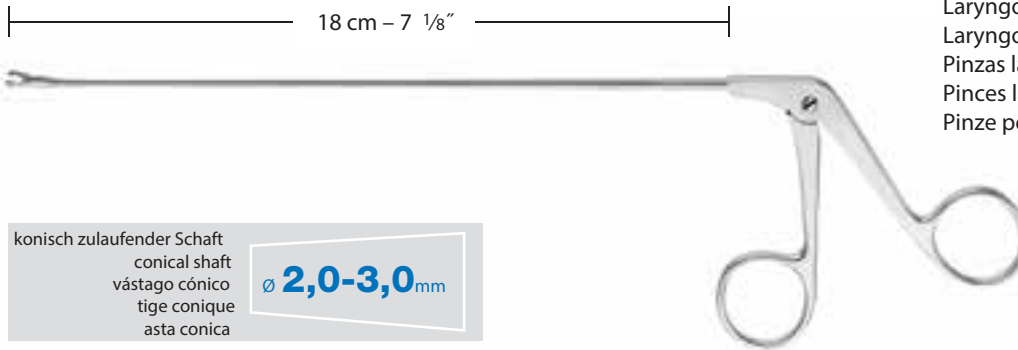

konisch zulaufender Schaft
 conical shaft
 vástago cónico
 tige conique
 asta conica

Ø 2,0-3,0mm

	Ø 1 mm	Ø 2 mm	Ø 3 mm	
	 73.18.04	 73.18.00	 73.18.02	gerade straight recta droit retta
	 73.18.05	 73.18.01	 73.18.03	aufgebogen curved upwards curva hacia arriba courbé en haut curva verso l'alto

	 73.18.07	gerade straight recta droit retta
	 73.18.08	aufgebogen curved upwards curva hacia arriba courbé en haut curva verso l'alto
	 73.18.09	rechts gebogen curva derecha curved right courbé à droite curva a destro
	 73.18.10	links gebogen curved left curva izquierda courbé à gauche curva a sinistro
	 Ø 4 mm 73.18.11	horizontal öffnend horizontal opening apertura horizontal ouverture horizontale apertura orizzontale
	 73.18.06	gerade straight recta droit retta



TREVALLi

**Endolaryngeale Mikrochirurgie
Endolaryngeal Micro Surgery
Microcirugía endolaringeal
Microchirurgie endolaryngienne
Microchirurgia endolaringeale**

24 cm – 9 1/2"

Schaft
Shaft
Vástago
Tige
Asta

Ø 2,0mm



	 73.30.00	
	 73.30.02	rechts gebogen curved right curva derecha courbé à droite curva a destro
	 73.30.03	links gebogen curved left curva izquierda courbé à gauche curva a sinistro
	 73.30.10	
	 73.30.11	
	 73.30.12	rechts gebogen curved right curva derecha courbé à droite curva a destro
	 73.30.13	links gebogen curved left curva izquierda courbé à gauche curva a sinistro
	 73.30.20	
	 73.30.21	
	 73.30.22	rechts gebogen curved right curva derecha courbé à droite curva a destro
	 73.30.23	links gebogen curved left curva izquierda courbé à gauche curva a sinistro
	 73.30.25	
	 73.30.65	Maulteile gefenstert jaw fenestrated boca fenestrada mors fenêtré morso finestrato

 gerade
straight
recta
droit
retta

 aufgewinkelt
angled upwards
angulada hacia arriba
coudé en haut
angolata verso l'alto







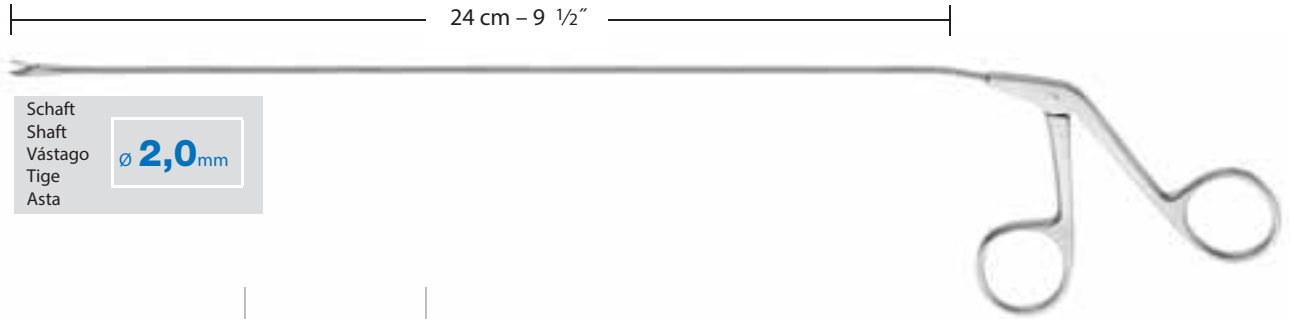

TREVALLi

Endolaryngeale Mikrochirurgie
Endolaryngeal Micro Surgery
Microcirugía endolaringeal
Microchirurgie endolaryngienne
Microchirurgia endolaringeale



Schaft
Shaft
Vástago
Tige
Asta

Ø **2,0**mm

	73.30.40	gerade straight recta droit retta
	73.30.41	aufgewinkelt angled upwards angulada hacia arriba coudé en haut angolata verso l'alto
	73.30.42	rechts gebogen curved right curva derecha courbé à droite curva a destro
	73.30.43	links gebogen curved left curva izquierda courbé à gauche curva a sinistro
	73.30.44	abgewinkelt angled downwards angulada hacia abajo coudé en bas angolata verso il basso
	73.30.45	gerade, horizontal schneidend straight, horizontal cutting recta, corte horizontal droit, à coupe horizontale retta, taglio orizzontale

23 cm – 9"

Nadelhalter
Needle holder
Porta-aguja
Porte-aiguille
Portaghi



konisch zulaufender Schaft
conical shaft
vástago cónico
tige conique
asta conica

Ø **2,0-3,0**mm



73.30.80



TREVALLI

Endolaryngeale Mikrochirurgie
Endolaryngeal Micro Surgery
Microcirugía endolaringeal
Microchirurgie endolaryngienne
Microchirurgia endolaringeale

Nadelhalter
Needle holder
Porta-aguja
Porte-aiguille
Portaghi

23 cm - 9"

Schaft
Shaft
Vástago
Tige
Asta

Ø 2,0mm

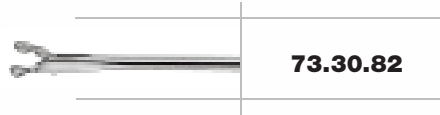

73.30.82



Stimmbandspreizer
Vocal cord retractor
Separador cuerdas vocales
Ecarteur cordes vocales
Divaricatore per corde vocali

27 cm - 10 3/4"

Schaft
Shaft
Vástago
Tige
Asta

Ø 2,0mm

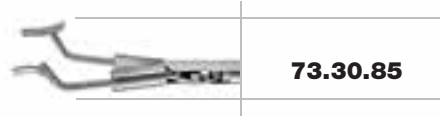

73.30.85



Saugkanülen
Suction cannulas
Cánulas de aspiración
Canules à aspiration
Cannule per aspirazione

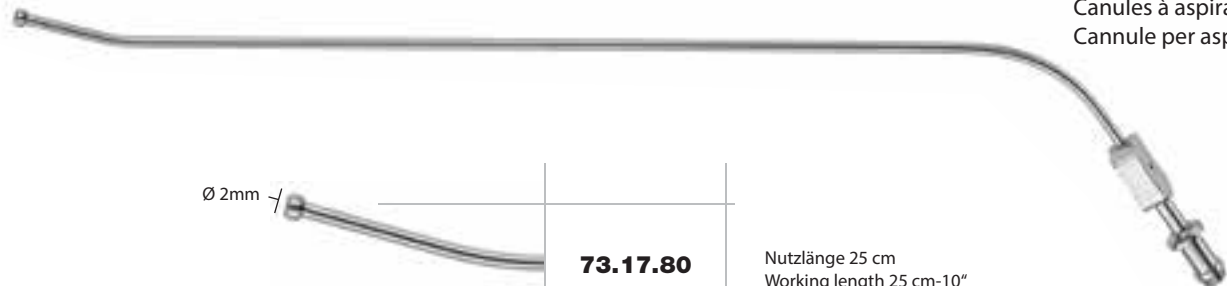

Ø 2mm		73.17.80
Ø 3mm		73.17.81

Nutzlänge 25 cm
Working length 25 cm-10"
Largo útil 25 cm
Longueur utile 25 cm
Lunghezza utile 25 cm



TREVALLi

Operations-Laryngoskope mit auswechselbarem Fiberglas-Lichtträger
Operating Laryngoscopes with exchangeable Fiber Optic Light Carrier
Laringoscopios para operaciones con portador de luz fibra óptica cambiabile
Laryngoscopes opératoires avec support de lumière en fibre de verre échangeable
Laringoscopi a sospensione con conduttore d'illuminazione fibra a ottica, cambiabile

für die vordere Kommissur
 for the anterior commissure
 para la comisura anterior
 pour la commissure antérieure
 per la commisura anteriore

Lichtträger mit Adapter **MEDICON/STORZ**
 Light carriers with adapter **WOLF**
 Portadores de luz con adaptador **ACMI**
 Supports de lumière avec adaptateur **ACMI**
 Conduttore d'illuminazione con connessione



erweitertes distales Ende, extrabreite proximale Öffnung
 extended distal tip, extra wide proximal opening
 extremo distal ensanchado, apertura proximal extra ancha
 extrémité distale élargie, ouverture proximale extra large
 estremita distale allargata, apertura prossimale extra larga

Holinger



Jackson



Ersatz-Lichtträger
 Spare light carriers
 Portadores de luz de repuesto
 Supports de lumière de rechange
 Supporti per illuminazione di ricambio

<p>74.00.20 L = 180 mm Holinger</p> <p>für Erwachsene for adults para adultos pour adultes per adulti</p>	74.01.12
<p>74.00.12 L = 120 mm Jackson</p> <p>für Säuglinge for babies para bebés pour nourissons per neonatali</p>	74.01.10
<p>74.00.17 L = 170 mm Jackson</p> <p>für Kinder for children para niños pour enfants per bambini</p>	74.01.11
<p>74.00.18 L = 180 mm Jackson</p> <p>für Erwachsene for adults para adultos pour adultes per adulti</p>	74.01.12



TREVALLI

Zubehör für Operations-Laryngoskope
Accessories for Operating Laryngoscopes
Accesorios para laringoscopios para operaciones
Accessoires pour laryngoscopes opératoires
Accessori per laringoscopi a sospensione

Laryngoskophalter mit Bruststütze für
 HOLINGER und JACKSON Laryngoskope

Laryngoscope holder with chest support for
 HOLINGER and JACKSON laryngoscopes

Porta-laringoscopio con soporte de pecho para
 laringoscopios de HOLINGER y JACKSON

Porte-laryngoscope avec support de
 poitrine pour laryngoscopes HOLINGER et JACKSON

Portalaringscopio con supporto sternale per
 laringoscopi HOLINGER e JACKSON

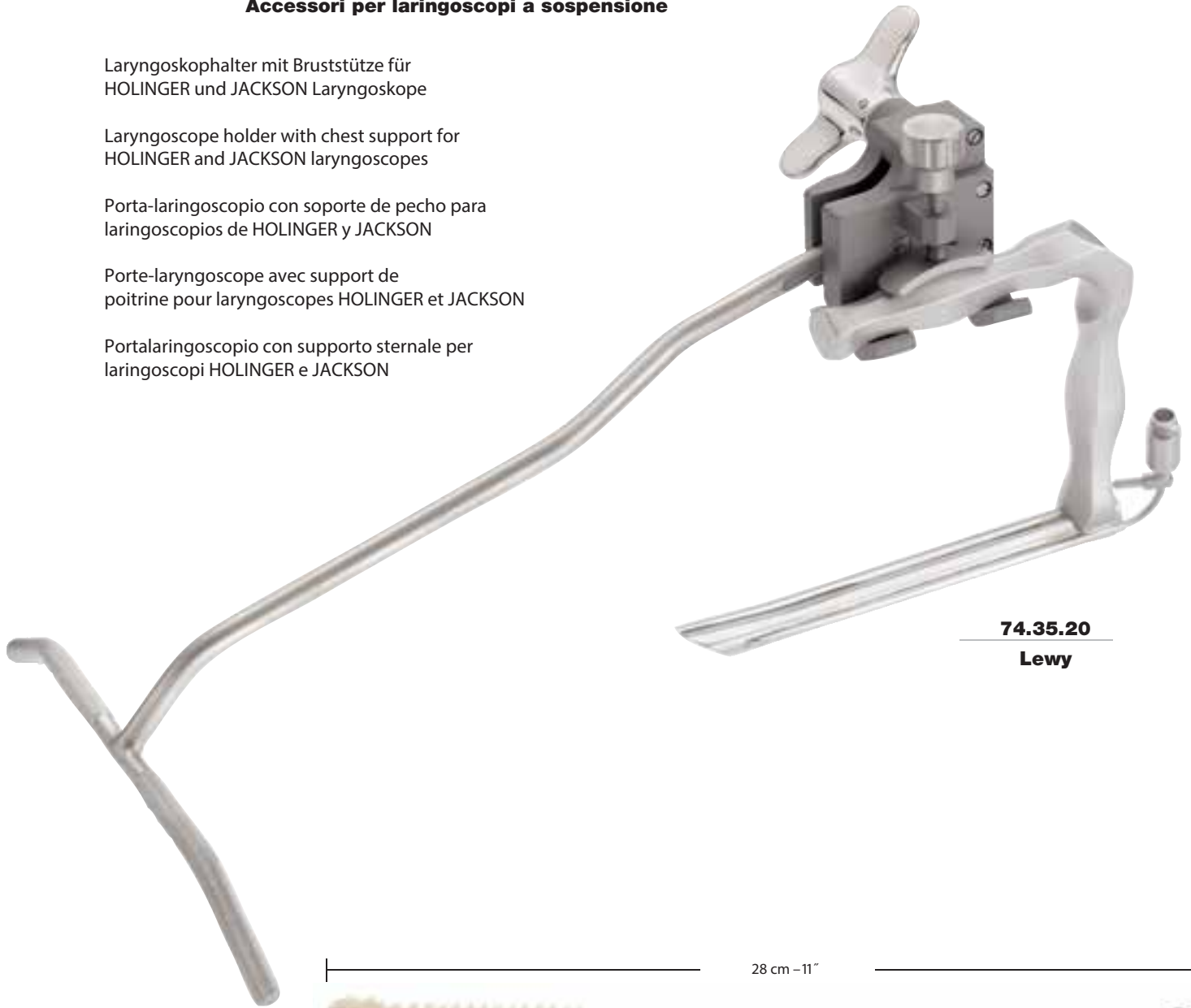

74.35.20
Lewy

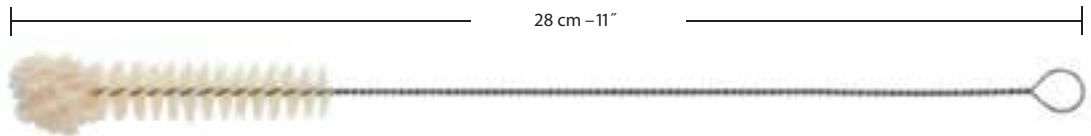

Reinigungsbürsten für Laryngoskope
 Cleaning brushes for laryngoscopes
 Cepillos de limpieza para laringoscopios
 Brosses de nettoyage pour laryngoscopes
 Spazzolini per pulire i laringoscopi

	Ø 14 mm	Ø 30 mm
	1 74.69.72	2 74.69.73
	mittel medium medio moyennes medio	groß large grande grandes grande



TREVALLi

Operations-Laryngoskope mit auswechselbarem Fiberglas-Lichtträger
Operating Laryngoscopes with exchangeable Fiber Optic Light Carrier
Laringoscopios para operaciones con portador de luz fibra óptica cambiabile
Laryngoscopes opératoires avec support de lumière en fibre de verre échangeable
Laringoscopi a sospensione con conduttore d'illuminazione fibra a ottica, cambiabile



Lichtträger mit Adapter
Light carriers with adapter
Portadores de luz con adaptador
Supports de lumière avec adaptateur
Conduttore d'illuminazione con connessione

MEDICON/STORZ

WOLF

ACMI



spreizbar
spreadable
para separar
à écarter
divaricabile



TREVALLi

#1 für Kleinkinder
for infants
para niños pequeños
pour petits enfants
per bambini in età da allattamento

#2 für Kinder
for children
para niños
pour enfants
per bambini

#3-7 für Erwachsene
for adults
para adultos
pour adultes
per adulti

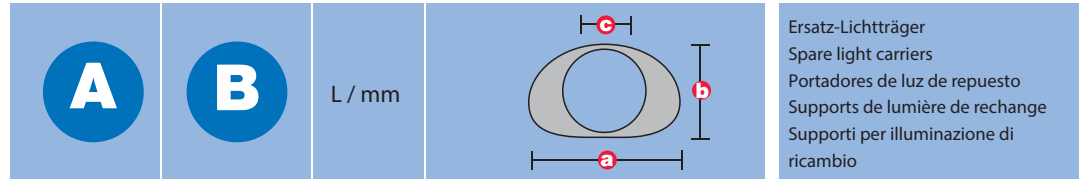

Ersatz-Lichtträger
Spare light carriers
Portadores de luz de repuesto
Supports de lumière de rechange
Supporti per illuminazione di ricambio

a/mm **b**mm **c**mm

	1	#1 74.00.01	#1 74.00.31	135	20	12	11	74.01.03
	1	#2 74.00.02	#2 74.00.32	152	21	13	11	74.01.03
	2	#3 74.00.03	#3 74.00.33	182	21	13	12	74.01.04
	2	#4 74.00.04	#4 74.00.34	172	27	15	14,5	74.01.04
	2	#5 74.00.05	#5 74.00.35	172	29	19	16	74.01.04
	2	#6 74.00.06	#6 74.00.36	182	26	17	13 × 19	74.01.04
	2	#7 74.00.07	#7 74.00.37	222	26	17	13 × 19	74.01.05



1 = 74.69.72

2 = 74.69.73

siehe Reinigungsbürsten, Seite 472
see cleaning brushes, page 472
véase cepillos de limpieza, página 472
voir brosses de nettoyage page 472
vedete spazzolini per pulire pagina 472

Zubehör Seite 475
Accessories page 475
Accesorios página 475
Accessoires page 475
Accessori pagina 475



TREVALLI

Zubehör für Operations-Laryngoskope
Accessories for Operating Laryngoscopes
Accesorios para laringoscopios para operaciones
Accessoires pour laryngoscopes opératoires
Accessori per laringoscopi a sospensione

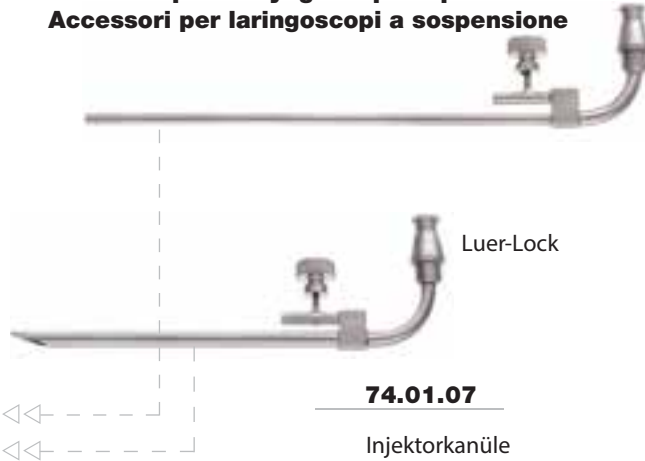

Luer-Lock

74.01.06

Rauchabsaugrohr
 Smoke suction tube
 Tubo extractor de humo
 Tube d'aspiration pour fumée
 Tubo d'aspirazione per fumo

für, for, para, pour, per
 74.00.01 - .07 + 74.00.31 - .37

74.01.07

Injektorkanüle
 Cannula injector
 Inyector para cánulas
 Moule à injection de canules
 Iniettore per cannule

für, for, para, pour, per
 74.00.01 - .07 + 74.00.31 - .37

für Kinder
 for children
 para niños
 pour enfants
 per bambini

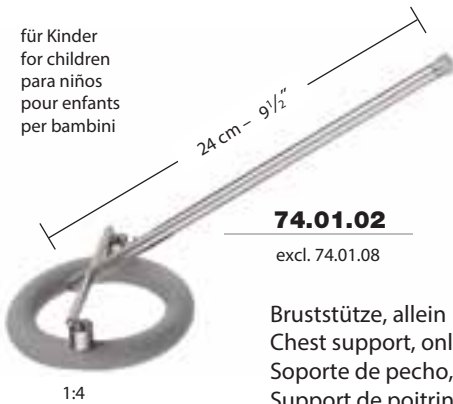

24 cm - 9 1/2"

74.01.02

excl. 74.01.08

Bruststütze, allein
 Chest support, only
 Soporte de pecho, solo
 Support de poitrine, seule
 Supporto sternale, solo

für, for, para, pour, per
 74.00.01 - .07 + 74.00.31 - .37

Laryngoskophalter mit Bruststütze
 Laryngoscope holder with chest support
 Porta-laringoscopio con soporte de pecho
 Porte-laryngoscope avec support de poitrine
 Portalaringscopio con supporto sternale

für, for, para, pour, per
 74.00.01 - .07 + 74.00.31 - .37

74.01.01

incl. 74.01.08



34 cm - 13 3/8"

1:4

für Erwachsene
 for adults
 para adultos
 pour adultes
 per adulti

74.01.08

Laryngoskophalter, allein
 Laryngoscope holder, only
 Porta-laringoscopio, solo
 Porte-laryngoscope, seul
 Portalaringscopio, solo





TREVALLi

**Instrumentarium zur oralen Endoskopie
Instruments for Oral Endoscopy
Instrumental para la endoscopia oral
Instruments pour l'endoscopie orale
Strumentario per endoscopia orale**

Endolaryngeale Mikrochirurgie
Endolaryngeal microsurgery
Microcirugia endolaringeal
Microchirurgie endolaryngienne
Microchirurgia endolaringea



1:1



24 cm – 9 1/2"

74.47.10

Sichelmesser
Sickle knife
Bisturí falciforme
Bistouri en forme de serpette
Bisturi a falce



24 cm – 9 1/2"

74.47.11

Larynxmesser
Laryngeal knife
Bisturí laringeal
Bistouri laringeal
Bisturi per laringe



24 cm – 9 1/2"

74.47.12

Rundmesser
Round edge knife
Cuchillo redondo
Bistouri à tranchant rond
Bisturi rotondo



24 cm – 9 1/2"

74.47.13

Messer Golfstockform
Knife golf club design
Cuchillo en forma de palo de golf
Couteau à forme de club
Coltello a forma di mazza da golf



24 cm – 9 1/2"

74.47.14

Rundmesser
Round edge knife
Cuchillo redondo
Bistouri à tranchant rond
Bisturi rotondo



24 cm – 9 1/2"

74.47.15

Rundmesser
Round edge knife
Cuchillo redondo
Bistouri à tranchant rond
Bisturi rotondo



24 cm – 9 1/2"

74.47.20

Larynxsonde
Laryngeal probe
Sonda laringeal
Sonda laryngienne
Sonda per laringe

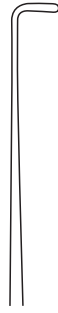

24 cm – 9 1/2"

74.47.21

Larynxhaken
Laryngeal hook
Gancho laringeal
Crochet laryngien
Uncino per laringe



24 cm – 9 1/2"

74.47.25

Larynxhaken
Laryngeal hook
Gancho laringeal
Crochet laryngien
Uncino per laringe

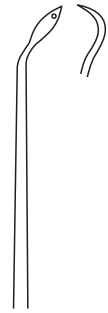

24 cm – 9 1/2"

74.47.27

Umstechungsnadel rechts gebogen
Needle curved right
Aguja curva derecha
Aiguille courbée à droite
Ago curva a destra



TREVALLi

**Instrumentarium zur oralen Endoskopie
Instruments for Oral Endoscopy
Instrumental para la endoscopia oral
Instruments pour l'endoscopie orale
Strumentario per endoscopia orale**

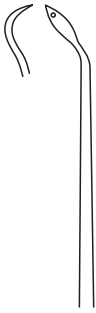

24 cm – 9 1/2"

74.47.28

Umstechungsnadel links gebogen
Needle curved left
Aguja curva izquierda
Aiguille courbée à gauche
Ago curva a sinistra

70°



24 cm – 9 1/2"

74.47.30

Larynxhaken
Laryngeal hook
Gancho laringeal
Crochet laryngien
Uncino per laringe



24 cm – 9 1/2"

74.47.35

Larynxhaken
Laryngeal hook
Gancho laringeal
Crochet laryngien
Uncino per laringe



24 cm – 9 1/2"

74.47.40

Elevatorium
Elevator
Elevador
Élévateur
Elevatore



24 cm – 9 1/2"

74.47.42

Knotenführer
Knot guide
Traslador de nudos
Guide-nœuds
Guida-nodi

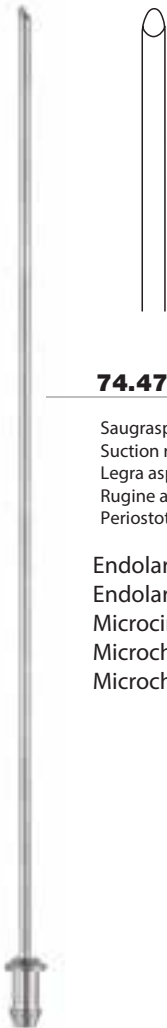

74.47.37

Saugraspatorium
Suction raspatory
Legra aspiradora
Rugine aspirateur
Periostotomo d'aspirazione

Endolaryngeale Mikrochirurgie
Endolaryngeal microsurgery
Microcirugía endolaringeal
Microchirurgie endolaryngienne
Microchirurgia endolaringea

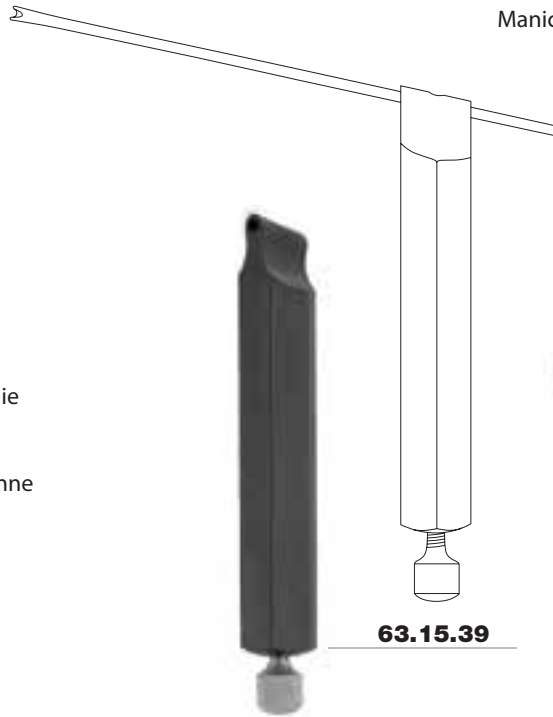

63.15.39

Heermann

Handgriffe für Stabinstrumente
Handles for use with instruments
Mangos para fijar instrumentos
Manches pour la fixation des instruments
Manici per strumenti



74.47.90



TREVALLI

Endolaryngeale Mikrochirurgie
Endolaryngeal microsurgery
Microcirugía endolaringeal
Microchirurgie endolaryngienne
Microchirurgia endolaringea

Instrumentarium zur oralen Endoskopie
Instruments for Oral Endoscopy
Instrumental para la endoscopia oral
Instrumentes pour l'endoscopie orale
Strumentario per endoscopia orale



Jako



31 cm – 12 1/8"

74.45.10

Sichelmesser
Sickle knife
Bisturi falciforme
Bistouri en forme de serpette
Bisturi a falce



31 cm – 12 1/8"

74.45.11

Larynxmesser
Laryngeal knife
Bisturi laringeal
Bistouri laryngien
Bisturi per laringe



31 cm – 12 1/8"

74.45.20

Larynxsonde
Laryngeal probe
Sonda laringeal
Sonde laryngienne
Sonda per laringe



31 cm – 12 1/8"

74.45.21

Larynxhaken
Laryngeal hook
Gancho laringeal
Crochet laryngien
Uncino per laringe



stumpf
blunt
romo
mousse
smussa

31 cm – 12 1/8"

74.45.40

Dissektor
Dissector
Disector
Dissecteur
Dissettore



22 cm – 8 3/4"

74.46.10

Sichelmesser
Sickle knife
Bisturi falciforme
Bistouri en forme de serpette
Bisturi a falce



Jako



24 cm – 9 1/2"

74.46.21

Larynxhaken
Laryngeal hook
Gancho laringeal
Crochet laryngien
Uncino per laringe



Jako



TREVALLi

Kehlkopf-Polypenzangen
Laryngeal Polypus Forceps
Pinzas para pólipos laringeales
Pinces pour polypes laryngiens
Pinze per polipi laringei

17 cm - 6¾"



Jurasz



73.46.01	▲
73.46.02	▼
73.46.03	▶
73.46.04	◀

Schaft
Shaft
Västago
Tige
Asta

Ø **3,0mm**

17 cm - 6¾"

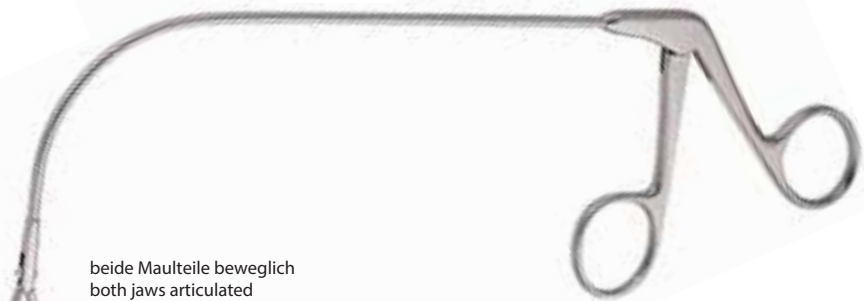

Fränkel

beide Maulteile beweglich
both jaws articulated
las dos bocas son móviles
à deux mâchoires mobiles
ambedue i morsi mobili



73.46.15

Schaft
Shaft
Västago
Tige
Asta

Ø **3,0mm**

17 cm - 6¾"

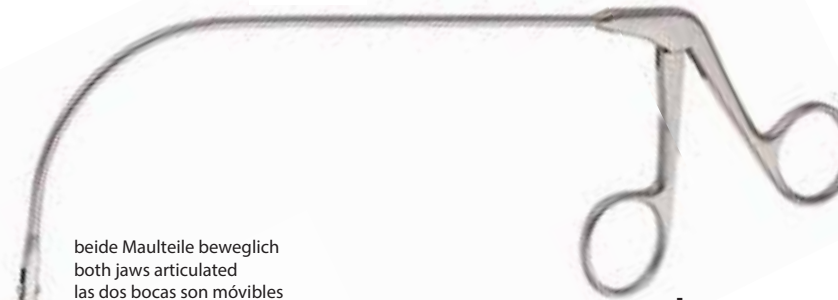

Lange

beide Maulteile beweglich
both jaws articulated
las dos bocas son móviles
à deux mâchoires mobiles
ambedue i morsi mobili



73.46.16

Schaft
Shaft
Västago
Tige
Asta

Ø **3,0mm**

▲ nach oben öffnend
opening upward
abriendo hacia arriba
ouvrant en haut
apertura verso l'alto

▼ nach unten öffnend
opening downward
abriendo hacia abajo
ouvrant en bas
apertura verso il basso

▶ nach rechts öffnend
opening right
abriendo hacia derecha
ouvrant à droite
apertura a destra

◀ nach links öffnend
opening left
abriendo hacia izquierda
ouvrant à gauche
apertura a sinistra



TREVALLi

Kehlkopf-Polypenzange, Kehlkopfpinzette
Laryngeal Polypus Forceps, Laryngeal Forceps
Pinza para pólipos laringeales, Pinza laringeal
Pince pour polypes laryngiens, Pince laryngiens
Pinza per polipi laringei, Pinza laringea

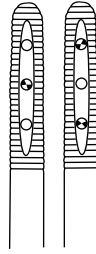

27 cm – 10 3/4"

73.46.57

Kehlkopfpinzette
Laryngeal forceps
Pinza laringeal
Pince laryngienne
Pinza laringea

Jackson

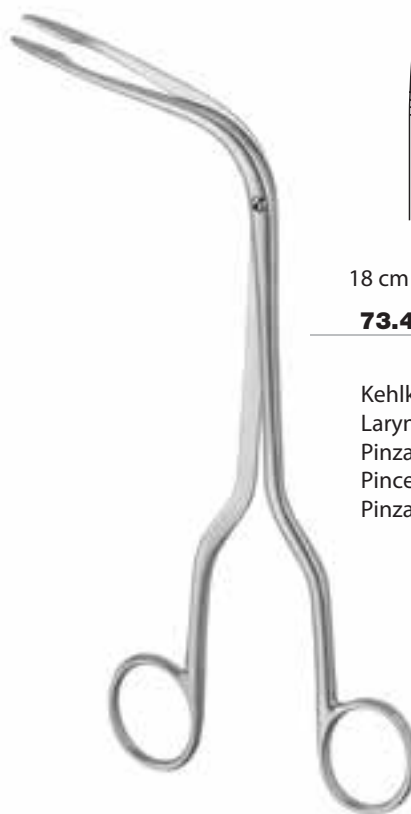

18 cm – 7 1/8"

73.46.18

Kehlkopf-Polypenzange
Laryngeal polypus forceps
Pinza para pólipos laringeales
Pince pour polypes laryngiens
Pinza per polipi laringei

Fränkel



TREVALLi

**Kehlkopfschere, Kehlkopf-Polypenschnürer
Laryngeal Scissors, Laryngeal Polypus Snare
Tijera laringeal, Cierranudo para pólipos
Ciseaux laryngiens, Serre-noeud pour polypes
Forbice laringea, Serranodo per polipi**

Schnürerdraht
Snare wire
Alambre de acero para polipotomo
Fil d'acier pour serre-noeud
Filo d'acciaio per serranodi

Ø 0,4 mm

72.50.97



20 cm – 8"

73.46.60

Kehlkopfschere
Laryngeal scissors
Tijera laringeal
Ciseaux laryngiens
Forbice laringea

Killian



73.46.70

Nutzlänge 24 cm
Working length 24 cm – 9½"
Largo útil 24 cm
Longueur utile 24 cm
Lunghezza utile 24 cm



TREVALLi

Kehlkopfspiegel und -griffe
Laryngeal Mirrors and Handles
Espejos y mangos laringeales
Miroirs et manches laryngiens
Specchietti e manici laringei

ohne Griff
without handle
sin mango
sans manche
senza manico



11,5 cm - 4 1/2"

73.47.55

mit Spannfutter
with chuck
con mandril de sujeción
avec mandrin de serrage
con mandrino

11 cm - 4 3/8"

73.47.50

mit Stellschraube
with adjusting screw
con tornillo de ajuste
avec vis de fixation
con vite di fissazione

000



Ø 6 mm

73.47.06 P₅

00



Ø 8 mm

73.47.08 P₅

0



Ø 10 mm

73.47.10 P₅

1



Ø 12 mm

73.47.12 P₅

2

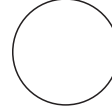

Ø 14 mm

73.47.14 P₅

3

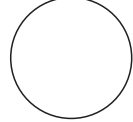

Ø 16 mm

73.47.16 P₅

4

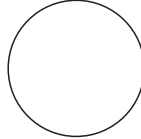

Ø 18 mm

73.47.18 P₅

5

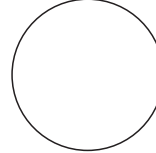

Ø 20 mm

73.47.20 P₅

6

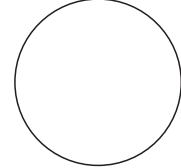

Ø 22 mm

73.47.22 P₅

7

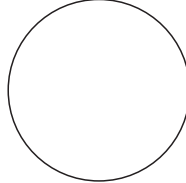

Ø 24 mm

73.47.24 P₅

8

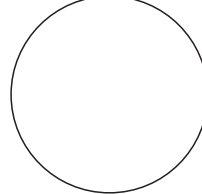

Ø 26 mm

73.47.26 P₅

9

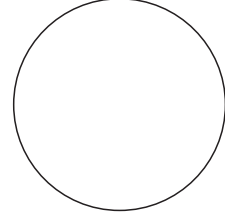

Ø 28 mm

73.47.28 P₅

10

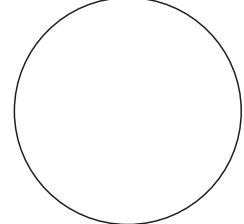

Ø 30 mm

73.47.30 P₅



Verpackungseinheit "X" Stück
Packing unit "X" pieces
Paquete de "X" unidades
Emballage de "X" pièces
Confezione da "X" pezzi



TREVALLi



22 cm - 8 3/4"

#000 Ø 6 mm 73.48.06	#00 Ø 8 mm 73.48.08	#0 Ø 10 mm 73.48.10
#1 Ø 12 mm 73.48.12	#2 Ø 14 mm 73.48.14	#3 Ø 16 mm 73.48.16
#4 Ø 18 mm 73.48.18	#5 Ø 20 mm 73.48.20	#6 Ø 22 mm 73.48.22
#7 Ø 24 mm 73.48.24	#8 Ø 26 mm 73.48.26	#9 Ø 28 mm 73.48.28
		#10 Ø 30 mm 73.48.30

**Kehlkopfspiegel
Laryngeal Mirrors
Espejos laringeales
Miroirs laryngiens
Specchietti laringei**



27 cm - 10 3/4"

10 cm - 4"

Ø 12 mm 73.48.92
Ø 14 mm 73.48.94
Ø 16 mm 73.48.96
Ø 18 mm 73.48.98

Michel

Rhinoskopiepiegel, beweglich
Rhinoscopic mirrors, movable
Espejos rinoscópicos, movable
Miroirs pour rhinoscopie, mobiles
Specchi per rinoscopia, mobile



TREVALLI

Kehlkopfwatteträger, Kehldeckelhalter
Laryngeal Cotton carriers, Epiglottis Retractor
Porta- algodones laringeales, Depresor para epiglotis
Portes-coton laryngiens, Dépresseur de l'épiglotte
Portacotone per laringe, Abbassa epiglottide



25 cm - 10"
73.49.25

Killian

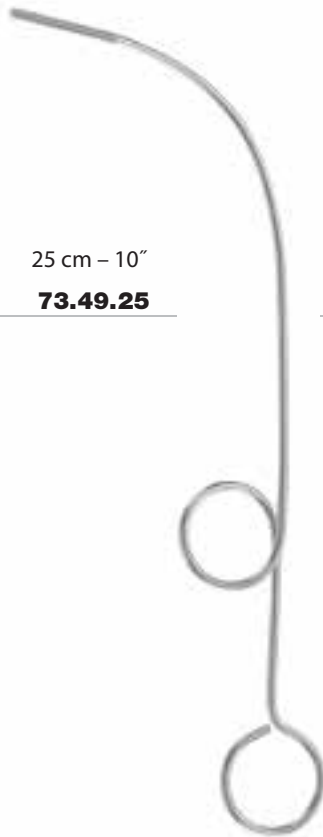

22,5 cm - 9"
73.49.30

Pelteson

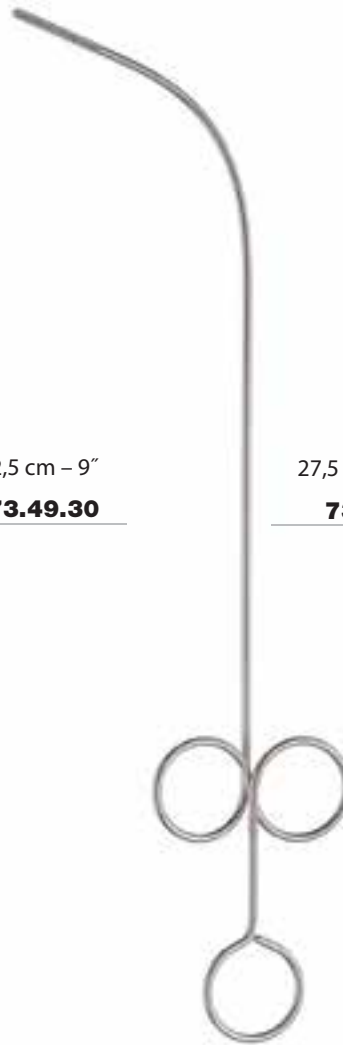

27,5 cm - 10 ³/₄"
73.49.35

Fein

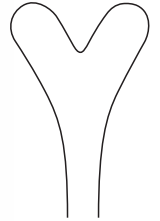

23 cm - 9"
73.49.45

Reichert



TREVALLi

**Kehlkopfkanülen, Spritzen
Laryngeal Cannulas, Syringes
Cánulas laringeal, Jeringas
Canules laryngiennes, Seringues
Cannule laringea, Siringhe**

Luer-Lock



5 ml

09.78.53

10 ml

09.78.54

Luer-Lock

Ersatzzylinder
Spare barrels
Cilindros de repuesto
Cylindres de rechange
Cilindri di ricambio



5 ml

09.78.43

10 ml

09.78.44

Kehlkopfkanüle
Laryngeal cannula
Cánula laringeal
Canule laryngienne
Cannula laringea



Ø 2,5 mm

73.49.71

Luer-Lock



Luer-Lock



27 cm – 10 3/4"

73.49.75



27,5 cm – 10 3/4"

73.49.77

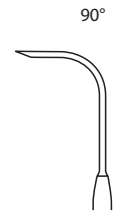

90°

26,5 cm – 10 1/2"

73.49.79

Kehlkopf-Injektionsnadeln
Laryngeal injection needles
Agujas de inyección laringeal
Aiguilles à injections pour larynx
Aghi per iniezioni laringee



TREVALLi

ENT INSTRUMENTS

Tracheotomie · Strumektomie
Tracheotomy · Thyroidectomy
Traqueotomía · Tiroidectomia
Trachéotomie · Thyroidectomie
Tracheotomia · Tiroidectomia

trevalli@mweb.co.za



TREVALLi

Trachealkanülen
Tracheal Tubes
Cánulas traqueales
Canules trachéales
Cannule tracheali

Internationale Größenskala für Trachealkanülen
 International scale of tracheal tube sizes
 Escala internacional de los tamaños de cánulas traqueales
 Echelle internationale des tailles de canules trachéales
 Scala internazionale per cannule tracheali

Fig.	0	1	2	3	4	5	6	7	8	9
mm Ø	4	5	6	7	8	9	10	11	12	13
Charr.	12	15	18	21	24	27	30	33	36	39
Länge mm length mm longitud en mm longueur en mm lunghezza mm.	45	50	55	60	65	70	75	80	85	90

Trachealkanülen, Standardmodell
 Tracheal tubes, standard pattern
 Cánulas traqueales, modelo estándar
 Canules trachéales, modèle standard
 Cannule tracheali, modello standard



Luer

Silber
 Sterling silver
 plata pura
 argent
 argento

73.50.54	Fig. 0	Ø 4 mm
73.50.55	Fig. 1	Ø 5 mm
73.50.56	Fig. 2	Ø 6 mm
73.50.57	Fig. 3	Ø 7 mm
73.50.58	Fig. 4	Ø 8 mm
73.50.59	Fig. 5	Ø 9 mm
73.50.60	Fig. 6	Ø 10 mm
73.50.61	Fig. 7	Ø 11 mm
73.50.62	Fig. 8	Ø 12 mm
73.50.63	Fig. 9	Ø 13 mm



TREVALLi

**Trachealkanülen
Tracheal Tubes
Cánulas traqueales
Canules trachéales
Cannule tracheali**



Chevalier-Jackson

Silber
Sterling silver
plata pura
argent
argento

73.57.54	Fig. 0	Ø 4 mm
73.57.55	Fig. 1	Ø 5 mm
73.57.56	Fig. 2	Ø 6 mm
73.57.57	Fig. 3	Ø 7 mm
73.57.58	Fig. 4	Ø 8 mm
73.57.59	Fig. 5	Ø 9 mm
73.57.60	Fig. 6	Ø 10 mm
73.57.61	Fig. 7	Ø 11 mm
73.57.62	Fig. 8	Ø 12 mm
73.57.63	Fig. 9	Ø 13 mm

Trachealkanülen mit Sprechventil
Speaking tubes
Cánulas traqueales con valvula para hablar
Canules trachéales pour parler
Cannule tracheali con valvola per parlare



Reinigungsbürste für Trachealkanülen
Cleaning brush for tracheal tubes
Cepillo para limpiar cánulas traqueales
Brosse de nettoyage pour canules trachéales
Spazzolino per pulire le cannule tracheali

19,5 cm – 7 3/4"

73.64.70

Ø 11 mm



Luer

Silber
Sterling silver
plata pura
argent
argento

73.60.58	Fig. 4	Ø 8 mm
73.60.59	Fig. 5	Ø 9 mm
73.60.60	Fig. 6	Ø 10 mm
73.60.61	Fig. 7	Ø 11 mm
73.60.62	Fig. 8	Ø 12 mm
73.60.63	Fig. 9	Ø 13 mm



TREVALLi

Tracheotomie Instrumente
Tracheotomy Instruments
Instrumentos para traqueotomía
Instruments pour trachéotomie
Strumenti per tracheotomia



Ø 3 mm

16 cm – 6 1/4"

73.65.15

für Säuglinge
for babies
para bebés
pour nourissons
per neonati

Tracheotomietrokar
Tracheotomy trocar
Trócar traqueal
Trocart pour trachéotomie
Trequarti per tracheotomia



scharf
sharp
agudo
tranchant
tagliente

16 cm – 6 1/4"

16 cm – 6 1/4"

73.65.32

73.65.33

Bose

Tracheotomiehäkchen
Tracheal hooks
Ganchitos para traqueotomía
Crochets trachéaux
Uncinetti tracheali



TREVALLi

**Tracheotomie Instrumente
Tracheotomy Instruments
Instrumentos para traqueotomía
Instruments pour trachéotomie
Strumenti per tracheotomia**

Trachealklemme
Tracheal artery forceps
Pinza-clamp traqueal
Pince-clamp trachéale
Pinza tracheale



Bose

7 cm – 2 3/4"

73.65.40

Tracheal-Wundspreizer
Tracheal retractor
Separador traqueal
Ecarteur trachéal
Divaricatore tracheale



Jackson

14,5 cm – 5 3/4"

73.65.64



Trousseau

12 cm – 4 3/4"

73.66.01

für Kinder
for children
para niños
pour enfants
per bambini

14 cm – 5 1/2"

73.66.02

für Erwachsene
for adults
para adultos
pour adultes
per adulti

Trachealdilatatoren
Tracheal dilators
Dilatadores traqueales
Dilatateurs trachéaux
Dilatatori tracheali



Laborde

13 cm – 5 1/8"

73.66.04

für Kinder
for children
para niños
pour enfants
per bambini

15 cm – 6"

73.66.03

für Erwachsene
for adults
para adultos
pour adultes
per adulti



TREVALLI

Tracheotomie Instrumente
 Tracheotomy Instruments
 Instrumentos para traqueotomía
 Instruments pour trachéotomie
 Strumenti per tracheotomia

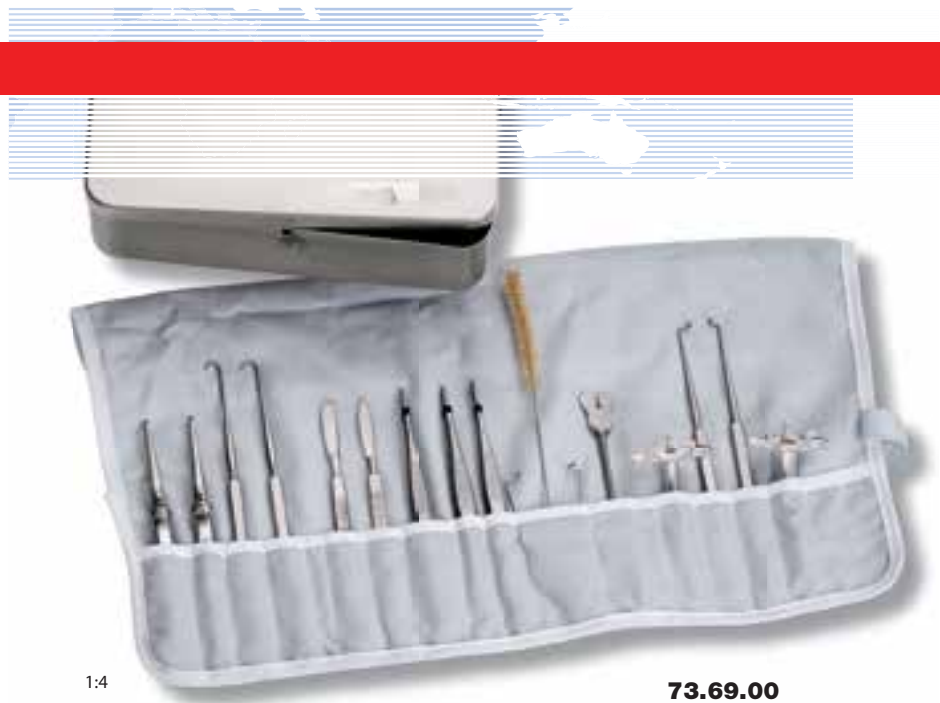

1:4

73.69.00

Tracheotomiebesteck I, bestehend aus:
Tracheotomy set no. I, consisting of:
Estuche para traqueotomía no. I, compuesto de:
Trousse pour trachéotomie no. I, se composant de:
Astuccio per tracheotomia no. I, composto da:

1	BERGMANN Skalpell BERGMANN Scalpel BERGMANN Bisturí BERGMANN Bistouri BERGMANN Bisturi	1 each	01.56.01 01.56.02	1	Anatomische Pinzette, 13 cm Dressing forceps, 13 cm – 5 1/8” Pinza anatómica, 13 cm Pince anatomique, 13 cm Pinza anatomica, 13 cm	06.00.13
1	BOSE Trachealhäkchen BOSE Tracheal hook BOSE Ganchito traqueal BOSE Crochet trachéal BOSE Uncinnetto tracheale	1 each	73.65.32 73.65.33	2	Chirurgische Pinzetten, 13 cm Tissue forceps, 13 cm – 5 1/8” Pinzas quirúrgicas, 13 cm Pinces chirurgicale, 13 cm Pinze chirurgiche, 13 cm	06.05.13
2	Trachealhäkchen, stumpf Tracheal hooks, blunt Ganchitos traqueales, romos Crochets trachéaux, mousses Uncinetti tracheali, smussi		20.65.01	2	FRICKE Unterbindungspinzetten mit Schiebeschloss FRICKE Ligature forceps with sliding lock FRICKE Pinzas para ligaduras con cierre corredizo FRICKE Pinces à ligatures avec fermeture à coulisse FRICKE Pinze per legatura con chiusura scorrevole	15.05.13
1	BOSE Tracheal-Wundspreizer BOSE Tracheal retractor BOSE Separador traqueal BOSE Ecarteur trachéal BOSE Divaricatore tracheale		73.65.40	1	Hohlsonde, 14,5 cm Grooved director, 14,5 cm – 5 3/4” Sonda acanalada, 14,5 cm Sonde boutonnée, 14,5 cm Sonda scanalata, 14,5 cm	09.15.14
1	LUER Trachealkanüle, Fig. 2 – Ø 6 mm, Silber LUER Tracheal tube, fig. 2 – Ø 6 mm, sterling silver LUER Cánula traqueal, fig. 2 – Ø 6 mm, plata pura LUER Canule trachéale, fig. 2 – Ø 6 mm, argent LUER Cannula tracheale, fig. 2 – Ø 6 mm, argento		73.50.56	1	Reinigungsbürste Cleaning brush Cepillo para limpiar Brosse de nettoyage Spazzolino per pulire	73.64.70
1	LUER Trachealkanüle, Fig. 4 – Ø 8 mm, Silber LUER Tracheal tube, fig. 4 – Ø 8 mm, sterling silver LUER Cánula traqueal, fig. 4 – Ø 8 mm, plata pura LUER Canule trachéale, fig. 4 – Ø 8 mm, argent LUER Cannula tracheale, fig. 4 – Ø 8 mm, argento		73.50.58		in sterilisierbarer Leinentasche in sterilizable canvas roll en bolsillo de tela esterilizabile le tout dans une trousse de toile stérilisable in borsa di tela sterilizzabile	996.00.08
					eingelegt in Metalletui placed in metal case alojado en caja de metal placé en boîte métallique alloggiata in scatola metallica	200 × 100 × 40 mm 46.52.40



TREVALLi

Tracheotomie Instrumente
Tracheotomy Instruments
Instrumentos para traqueotomía
Instrumentos pour trachéotomie
Strumenti per tracheotomia



1:4

73.69.50

Tracheotomiebesteck II, bestehend aus:
Tracheotomy set no. II, consisting of:
Estuche para traqueotomía no. II, compuesto de:
Trousse pour trachéotomie no. II, se composant de:
Astuccio per tracheotomia no. II, composto di:

1	BERGMANN Skalpell BERGMANN Scalpel BERGMANN Bisturí BERGMANN Bistouri BERGMANN Bisturi	01.56.01
1	Trachealhäkchen, scharf Tracheal hook, sharp Ganchito traqueal, agudo Crochet trachéal, pointu Uncinetto tracheale, acuto	20.64.01
1	TROUSSEAU Trachealdilatator TROUSSEAU Tracheal dilator TROUSSEAU Dilatador traqueal TROUSSEAU Dilatateur trachéal TROUSSEAU Dilatatore tracheale	73.66.02
1	LUER Trachealkanüle, Fig. 2 – Ø 6 mm, Silber LUER Tracheal tube, fig. 2 – Ø 6 mm, Sterling silver LUER Cánula traqueal, fig. 2 – Ø 6 mm, plata pura LUER Canule trachéale, fig. 2 – Ø 6 mm, argent LUER Cannula tracheale, fig. 2 – Ø 6 mm, argento	73.50.56

1	LUER Trachealkanüle, Fig. 4 – Ø 8 mm, Silber LUER Tracheal tube, fig. 4 – Ø 8 mm, Sterling silver LUER cánula traqueal, fig. 4 – Ø 8 mm, plata pura LUER Canule trachéale, fig. 4 – Ø 8 mm, argent LUER Cannula tracheale, fig. 4 – Ø 8 mm, argento	73.50.58
---	---	----------

in sterilisierbarer Leinentasche
in sterilizable canvas roll
en bolsillo de tela esterilizable
le tout dans une trousse de toile stérilisable
in borsa di tela sterilizzabile

996.00.08

ingelegt in Metalletui
placed in metal case
alojado en caja de metal
placé en boîte métallique
alloggiata in scatola metallica

200 × 100 × 40 mm
46.52.40



TREVALLI

Kropfsonden
Thyroid dissectors
Sondas para bocio
Sondes à goitre
Sonde per gozzo

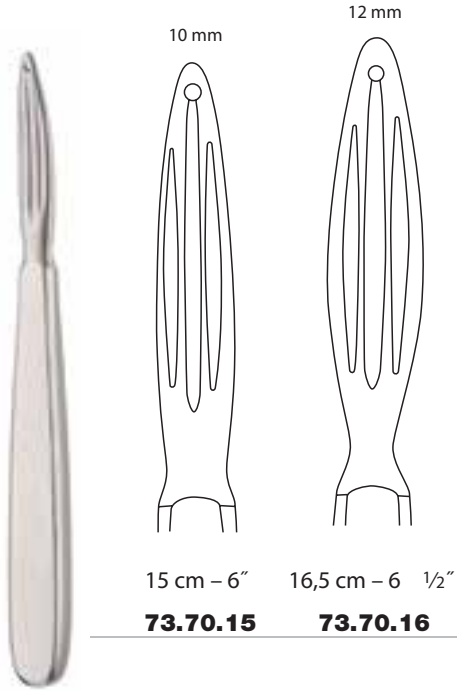

15 cm – 6" **73.70.15** 16,5 cm – 6 1/2" **73.70.16**

Kocher

**Strumektomie Instrumente
Thyroidectomy Instruments
Instrumentos para estrumectomía
Instruments pour thyroïdectomie
Strumenti per strumatomia**

Kropfsondenschere
Thyroid dissecting scissors
Tijera-exploradora para bocio
Ciseaux à goitre
Forbice esploratrici per gozzo



15 cm – 6" **73.71.15**

Schoemaker



15 cm – 6" **73.72.32**

Lovelace

Kropffasszangen
Goiter forceps
Pinzas prensoras de bocio
Pincas à préhension pour goitre
Pinza da presa per gozzo



15 cm – 6" **73.72.33**

Lahey



TREVALLi

ENT INSTRUMENTS

Hochfrequenz-Chirurgie
High Frequency Surgery
Cirurgía de alta frecuencia
Chirurgie à haute fréquence
Chirurgia ad alta frequenza

trevalli@mweb.co.za



TREVALLi

Elektrodenhandgriffe
Electrode Handles
Mangos porta electrodos
Manches pour électrodes
Manipoli per elettrodi

Elektrodenhandgriffe mit fest verbundenem Kabel
 Electrode handles with fixed cable
 Mangos porta electrodos con cable fijo
 Manches pour électrodes avec câble fixe
 Manipoli per elettrodi con cavo fisso

Erbe ACC

Ø 5 mm



Valleylab
 Martin
 Erbe ICC International



Ø 4 mm



4,5 m
87.33.70

3 m
87.33.71

4,5 m
87.33.72

Ø 2,4 mm



4,5 m
87.33.75

4,5 m
87.33.77

Martin
 Berchtold

Ø 12,5 mm



3 m
87.33.80

Ø 4 mm



3 m
87.33.81

Dental-Elektrodenhandgriffe mit fest verbundenem Kabel
 Dental electrode handles with fixed cable
 Mangos porta electrodos dentales con cable fijo
 Manches pour électrodes dentaires avec câble fixe
 Manipoli per elettrodi dentali con cavo fisso

Ø 1,6 mm





TREVALLi

Elektroden, monopolar
Electrodes, monopolar
Electrodos, monopolares
Electrodes, monopolaires
Elettrodi, monopolari



Drahtschlingenelektroden Wire loop electrodes Electrodo de lazo de alambre Electrodes à anse en fil Elettrodi ad ansa di filo	87.30.45 87.30.50	\varnothing 4 mm \varnothing 5 mm \varnothing 10 mm	
Bandschlingenelektroden Ribbon loop electrodes Electrodo de lazo de cinta Electrodes à anse de ruban Elettrodi ad ansa a nastro	87.30.60 87.30.65 87.30.70	\varnothing 10 mm \varnothing 15 mm \varnothing 20 mm	
Kugelelektroden Ball electrodes Electrodo de bola Electrodes à boule Elettrodi a sfera	87.30.72 87.30.74 87.30.76	\varnothing 2,5 mm \varnothing 4 mm \varnothing 6 mm	
Lanzettenelektrode Lancet electrode Electrodo de lanceta Electrodes à lancette Elettrodo a lancetta	87.30.12		
Lanzettenelektrode Lancet electrode Electrodo de lanceta Electrodes à lancette Elettrodo a lancetta	87.30.17		
Messerelektroden Knife electrodes Electrodo de cuchillo Electrodes à couteau Elettrodi a bisturi	87.30.20 87.30.25	a = 20 mm a = 25 mm	
Nadelelektroden Needle electrodes Electrodo de aguja Electrodes à aiguille Elettrodi ad ago	87.30.35 87.30.38	\varnothing 0,5 mm \varnothing 0,8 mm	

Abbildungen 1:1
 Illustrations 1:1
 Ilustraciones 1:1
 Illustrations 1:1
 Illustrazioni 1:1



TREVALLi

Elektroden, monopolar
Electrodes, monopolar
Electrodos, monopolares
Electrodes, monopolaires
Elettrodi, monopolari

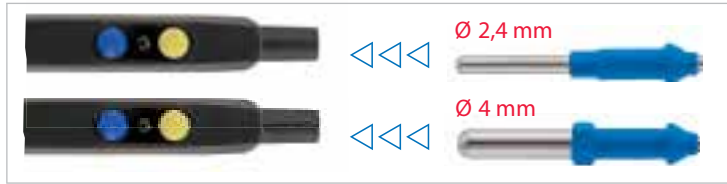

	Ø 4 mm	Ø 2,4 mm	
Messerelektroden Knife electrodes Electrodos de cuchillo Electrodes à couteau Elettrodi a bisturi	87.32.00	87.33.00	
Messerelektroden Knife electrodes Electrodos de cuchillo Electrodes à couteau Elettrodi a bisturi	87.32.02	87.33.02	
Spatuelektroden Spatula electrodes Electrodos de espátula Electrodes à spatule Elettrodi a spatola	87.32.04	87.33.04	
Spatuelektroden Spatula electrodes Electrodos de espátula Electrodes à spatule Elettrodi a spatola	87.32.06	87.33.06	
Lanzettenelektroden Lancet electrodes Electrodos de lanceta Electrodes à lancette Elettrodi a lancetta	87.32.08	87.33.08	
Lanzettenelektrode Lancet electrode Electrodo de lanceta Electrodes à lancette Elettrodo a lancetta	87.32.10	87.33.10	
Nadelelektroden Needle electrodes Electrodos de aguja Electrodes à aiguille Elettrodi ad ago	87.32.12	87.33.12	
Nadelelektroden Needle electrodes Electrodos de aguja Electrodes à aiguille Elettrodi ad ago	87.32.14	87.33.14	

Abbildungen 1:1
 Illustrations 1:1
 Ilustraciones 1:1
 Illustrations 1:1
 Illustrazioni 1:1



TREVALLi

Elektroden, monopolar
Electrodes, monopolar
Electrodos, monopolares
Electrodes, monopolaires
Elettrodi, monopolari

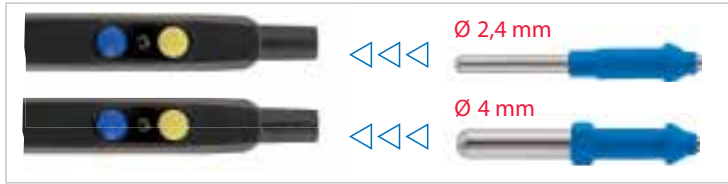

	Ø 4 mm	Ø 2,4 mm	
Drahtschlingenelektroden Wire loop electrodes Electrodos de lazo de alambre Electrodes à anse en fil Elettrodi ad ansa di filo	Ø 14 mm 87.32.16	Ø 14 mm 87.33.16	
Drahtschlingenelektroden Wire loop electrodes Electrodos de lazo de alambre Electrodes à anse en fil Elettrodi ad ansa di filo	Ø 10 mm 87.32.18	Ø 10 mm 87.33.18	
Drahtschlingenelektroden Wire loop electrodes Electrodos de lazo de alambre Electrodes à anse en fil Elettrodi ad ansa di filo	Ø 5 mm 87.32.20	Ø 5 mm 87.33.20	
Bandschlingenelektroden Ribbon loop electrodes Electrodos de lazo de cinta Electrodes à anse de ruban Elettrodi ad ansa a nastro	Ø 17 mm 87.32.22		
Bandschlingenelektroden Ribbon loop electrodes Electrodos de lazo de cinta Electrodes à anse de ruban Elettrodi ad ansa a nastro	Ø 10 mm 87.32.24	Ø 10 mm 87.33.24	
Kugelelektroden Ball electrodes Electrodos de bola Electrodes à boule Elettrodi a sfera	Ø 6 mm 87.32.26	Ø 6 mm 87.33.26	
Kugelelektroden Ball electrodes Electrodos de bola Electrodes à boule Elettrodi a sfera	Ø 4 mm 87.32.28	Ø 4 mm 87.33.28	
Kugelelektroden Ball electrodes Electrodos de bola Electrodes à boule Elettrodi a sfera	Ø 4 mm 87.32.30	Ø 4 mm 87.33.30	





Abbildungen 1:1
 Illustrations 1:1
 Ilustraciones 1:1
 Illustrations 1:1
 Illustrazioni 1:1

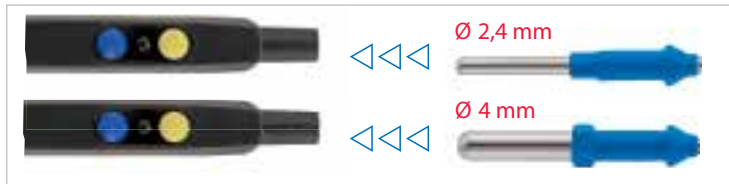

TREVALLi

Elektroden, monopolar
Electrodes, monopolar
Electrodos, monopolares
Electrodes, monopolaires
Elettrodi, monopolari



	Ø 4 mm	Ø 2,4 mm	
Kugelelektroden Ball electrodes Electrodos de bola Electrodes à boule Elettrodi a sfera	Ø 2 mm 87.32.32	Ø 2 mm 87.33.32	
Kugelelektroden Ball electrodes Electrodos de bola Electrodes à boule Elettrodi a sfera	Ø 2 mm 87.32.34	Ø 2 mm 87.33.34	
Kugelelektrode Ball electrode Electrodo de bola Electrodes à boule Elettrodo a sfera	Ø 1,5 mm 87.32.36		
Kugelelektrode Ball electrode Electrodo de bola Electrodes à boule Elettrodo a sfera	Ø 1,5 mm 87.32.38		

Nadelelektrode
 Needle electrode
 Electrodo de aguja
 Electrode à aiguille
 Elettrodo ad ago



Abbildungen 1:1
 Illustrations 1:1
 Ilustraciones 1:1
 Illustrations 1:1
 Illustrazioni 1:1



TREVALLi

Elektrodenverlängerungen
Electrode extensions
Alargamientos para electrodos
Rallonges d'électrodes
Prolunghe elettrodi

für Elektroden
for electrodes
para electrodos
pour électrodes
per elettrodi

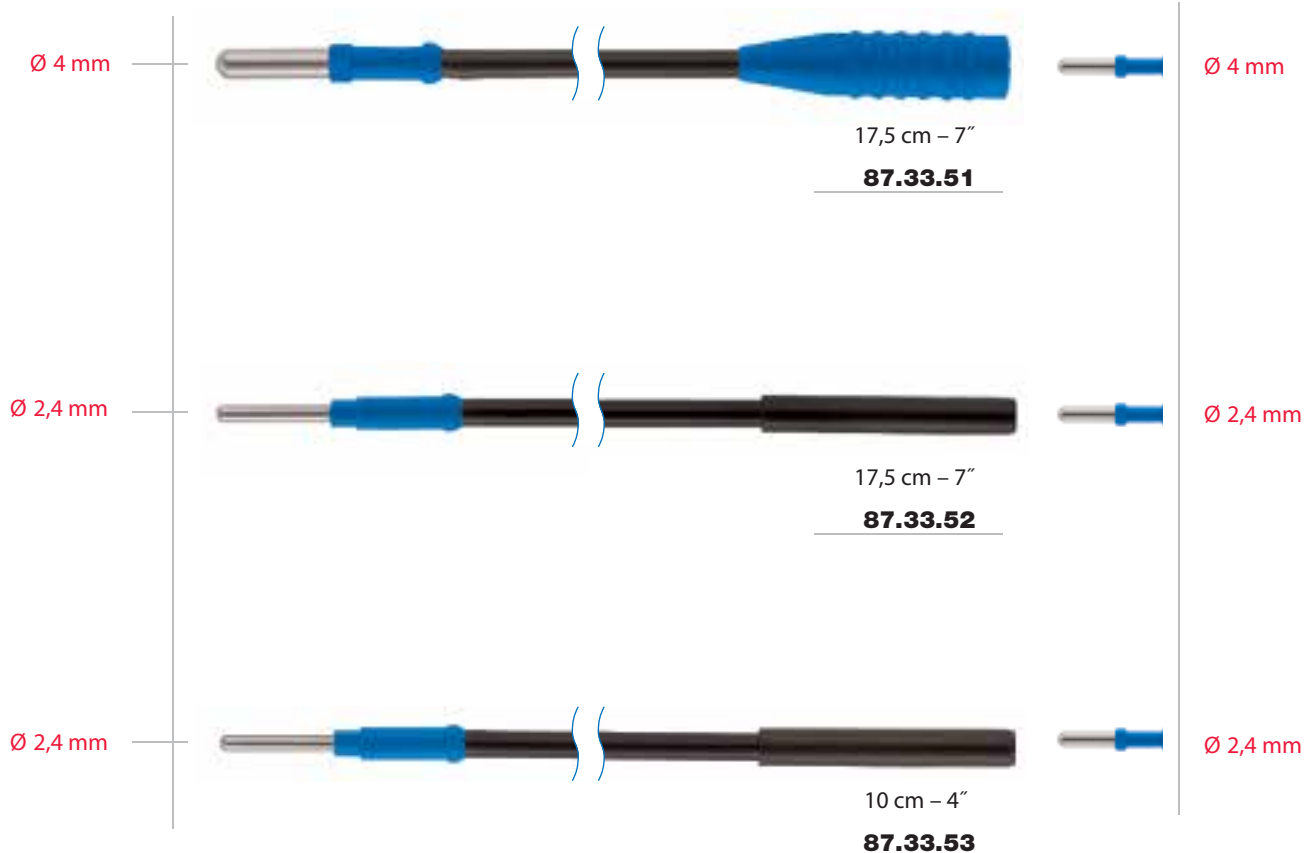

Abbildungen 1:1
Illustrations 1:1
Ilustraciones 1:1
Illustrations 1:1
Illustrazioni 1:1



TREVALLi

Elektroden, monopolar
Electrodes, monopolar
Electrodos, monopolares
Electrodes, monopolaires
Elettrodi, monopolari

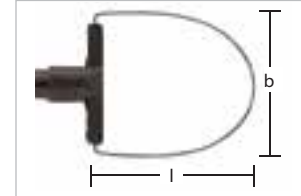

	l × b	
Drahtschlingenelektrode Wire loop electrode Electrodo de lazo de alambre Electrode à anse en fil Elettrodo ad ansa di filo	20×20 mm 87.34.00	
Drahtschlingenelektrode Wire loop electrode Electrodo de lazo de alambre Electrode à anse en fil Elettrodo ad ansa di filo	15×20 mm 87.34.01	
Drahtschlingenelektrode Wire loop electrode Electrodo de lazo de alambre Electrode à anse en fil Elettrodo ad ansa di filo	10×10 mm 87.34.02	
Messerelektrode Knife electrode Electrodo de cuchillo Electrode à couteau Elettrodo a bisturi	87.34.10	
Lanzettenelektrode Lancet electrode Electrodo de lanceta Electrode à lancette Elettrodo a lancetta	87.34.11	
Lanzettenelektrode Lancet electrode Electrodo de lanceta Electrode à lancette Elettrodo a lancetta	87.34.12	

Nutzlänge ca. 10 cm
 Working length approx. 10 cm – 4"
 Largo útil aprox. 10 cm
 Longueur utile env. 10 cm
 Lunghezza utile ca. 10 cm



TREVALLi

Elektroden, monopolar
Electrodes, monopolar
Electrodos, monopolares
Electrodes, monopolaires
Elettrodi, monopolari



Nadelelektrode Needle electrode Electrodo de aguja Electrode à aiguille Elettrodo ad ago	87.34.15	
Nadelelektrode Needle electrode Electrodo de aguja Electrode à aiguille Elettrodo ad ago	87.34.16	
Drahtschlingenelektrode Wire loop electrode Electrodo de lazo de alambre Electrode à anse en fil Elettrodo ad ansa di filo	\varnothing 10 mm 87.34.20	
Drahtschlingenelektrode Wire loop electrode Electrodo de lazo de alambre Electrode à anse en fil Elettrodo ad ansa di filo	\varnothing 5 mm 87.34.21	
Kugelelektrode Ball electrode Electrodo de bola Electrode à boule Elettrodo a sfera	\varnothing 6 mm 87.34.25	
Kugelelektrode Ball electrode Electrodo de bola Electrode à boule Elettrodo a sfera	\varnothing 6 mm 87.34.26	
Kugelelektrode Ball electrode Electrodo de bola Electrode à boule Elettrodo a sfera	\varnothing 4 mm 87.34.27	

Nutzlänge ca. 10 cm
Working length approx. 10 cm – 4"
Largo útil aprox. 10 cm
Longueur utile env. 10 cm
Lunghezza utile ca. 10 cm



TREVALLi

Elektroden, monopolar
Electrodes, monopolar
Electrodos, monopolares
Electrodes, monopolaires
Elettrodi, monopolari



Nadelelektrode Needle electrode Electrodo de aguja Electrode à aiguille Elettrodo ad ago	Ø 0,2 mm 87.31.32	# 1	
Nadelelektrode Needle electrode Electrodo de aguja Electrode à aiguille Elettrodo ad ago	Ø 0,2 mm 87.31.37	# 2	
Drahtschlingenelektrode Wire loop electrode Electrodo de lazo de alambre Electrode à anse en fil Elettrodo ad ansa di filo	Ø 3 mm 87.31.42	# 11	
Drahtschlingenelektrode Wire loop electrode Electrodo de lazo de alambre Electrode à anse en fil Elettrodo ad ansa di filo	Ø 5 mm 87.31.45	# 12	
Drahtschlingenelektrode Wire loop electrode Electrodo de lazo de alambre Electrode à anse en fil Elettrodo ad ansa di filo	Ø 8 mm 87.31.48	# 13	
Drahtschlingenelektrode, rhombusförmig Wire loop electrode, rhombic Electrodo de lazo de alambre, romboidal Electrode à anse en fil, rhomboidale Elettrodo ad ansa di filo, romboidale	87.31.54	# 14	

Abbildungen 1:1
 Illustrations 1:1
 Ilustraciones 1:1
 Illustrations 1:1
 Illustrazioni 1:1



TREVALLi

Elektroden, monopolar
Electrodes, monopolar
Electrodos, monopolares
Electrodes, monopolaires
Elettrodi, monopolari



Drahtschlingenelektrode Wire loop electrode Electrodo de lazo de alambre Electrode à anse en fil Elettrodo ad ansa di filo	7 × 1,5 mm 87.31.56	# 15	45°
Drahtschlingenelektrode Wire loop electrode Electrodo de lazo de alambre Electrode à anse en fil Elettrodo ad ansa di filo	6 × 1,3 mm 87.31.57	# 17	45°
Drahtschlingenelektrode Wire loop electrode Electrodo de lazo de alambre Electrode à anse en fil Elettrodo ad ansa di filo	7 × 1,7 mm 87.31.63	# 18	30°
Drahtschlingenelektrode Wire loop electrode Electrodo de lazo de alambre Electrode à anse en fil Elettrodo ad ansa di filo	7 × 1,7 mm 87.31.64	# 19	45°
Drahtschlingenelektrode Wire loop electrode Electrodo de lazo de alambre Electrode à anse en fil Elettrodo ad ansa di filo	7 × 1,4 mm 87.31.65	# 20	45°
Drahtschlingenelektrode Wire loop electrode Electrodo de lazo de alambre Electrode à anse en fil Elettrodo ad ansa di filo	7 × 1,7 mm 87.31.62	# 21	45°





Abbildungen 1:1
 Illustrations 1:1
 Ilustraciones 1:1
 Illustrations 1:1
 Illustrazioni 1:1



TREVALLi

Elektroden, monopolar
Electrodes, monopolar
Electrodos, monopolares
Electrodes, monopolaires
Elettrodi, monopolari



Koagulations-Nadelelektrode Coagulating needle electrode Electrodo de aguja para coagulación Electrode à aiguille pour coagulation Elettrodo ad ago per coagulazione	Ø 0,6 mm 87.31.67	# 31	
Kugelelektrode Ball electrode Electrodo de bola Electrode à boule Elettrodo a sfera	Ø 1,7 mm 87.31.71	# 33	
Kugelelektrode Ball electrode Electrodo de bola Electrode à boule Elettrodo a sfera	Ø 3 mm 87.31.73	# 34	
Koagulations- und Fulgurationselektrode Coagulating and fulgurating electrode Electrodo para coagulación y fulguración Electrode de coagulation et de fulguration Elettrodo per coagulazione e fulgurazione	87.31.68	# 35	
Epilationsnadelelektrode Needle electrode for epilation Electrodo de aguja para la epilación Electrode à aiguille pour l'épilation Elettrodo ad ago per l'epilazione	87.31.69		

Abbildungen 1:1
Illustrations 1:1
Ilustraciones 1:1
Illustrations 1:1
Illustrazioni 1:1



TREVALLI

Koagulationspinzetten, monopolar
Coagulation Forceps, monopolar
Pinzas de coagulación, monopolares
Pinces pour coagulation, monopolaires
Pinze per coagulazione, monopolari



Isomed



18 cm - 7 1/8"	87.02.18
21 cm - 8 1/4"	87.02.21
25 cm - 10"	87.02.25



Isomed



18 cm - 7 1/8"	87.05.18
21 cm - 8 1/4"	87.05.21
25 cm - 10"	87.05.25



Isomed



18 cm - 7 1/8"
87.06.18



Isomed



18 cm - 7 1/8"
87.06.19



TREVALLi

Koagulationspinzetten, monopolar
Coagulation Forceps, monopolar
Pinzas de coagulación, monopolares
Pinces pour coagulation, monopolaires
Pinze per coagulazione, monopolari



Isomed



18 cm – 7 1/8"	87.02.68
21 cm – 8 1/4"	87.02.71
25 cm – 10"	87.02.75



Isomed



18 cm – 7 1/8"	87.05.68
21 cm – 8 1/4"	87.05.71
25 cm – 10"	87.05.75



Isomed



18 cm – 7 1/8"
87.06.68



Isomed



18 cm – 7 1/8"
87.06.69

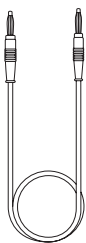

passendes Anschlusskabel Nr. 87.30.96 (siehe Seite 523)
suitable connecting cable No. 87.30.96 (see page 523)
cable de conexión apropiado No. 87.30.96 (vean pagina 523)
câble de raccordement approprié No. 87.30.96 (voir page 523)
cavo di collegamento appropriato No. 87.30.96 (vedi pagina 523)



TREVALLi

Koagulationspinzetten, bipolar
Coagulation Forceps, bipolar
Pinzas de coagulación, bipolares
Pinces pour coagulation, bipolaires
Pinze per coagulazione, bipolari



11 cm - 4 3/8"

88.12.05

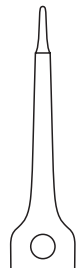

11 cm - 4 3/8"

88.12.06

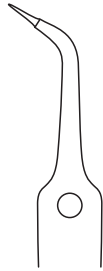

11 cm - 4 3/8"

88.12.07



11 cm - 4 3/8"

88.12.08



16,5 cm - 6 1/2"

88.17.16

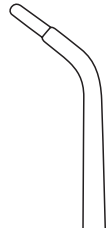

16,5 cm - 6 1/2"

88.17.18



16,5 cm - 6 1/2"

88.17.05



16,5 cm - 6 1/2"

88.17.06



16,5 cm - 6 1/2"

88.17.07



16,5 cm - 6 1/2"

88.17.08



16,5 cm - 6 1/2"

88.17.25



16,5 cm - 6 1/2"

88.17.26





TREVALLi

Koagulationspinzetten, bipolar
Coagulation Forceps, bipolar
Pinzas de coagulación, bipolares
Pinces pour coagulation, bipolaires
Pinze per coagulazione, bipolari



20 cm - 8"
88.20.05



20 cm - 8"
88.20.06

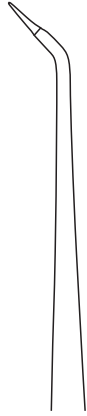

20 cm - 8"
88.20.07



20 cm - 8"
88.20.08



20 cm - 8"
88.20.16

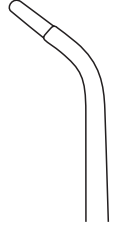

20 cm - 8"
88.20.18



20 cm - 8"
88.20.25



20 cm - 8"
88.20.26

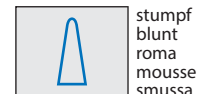



TREVALLi

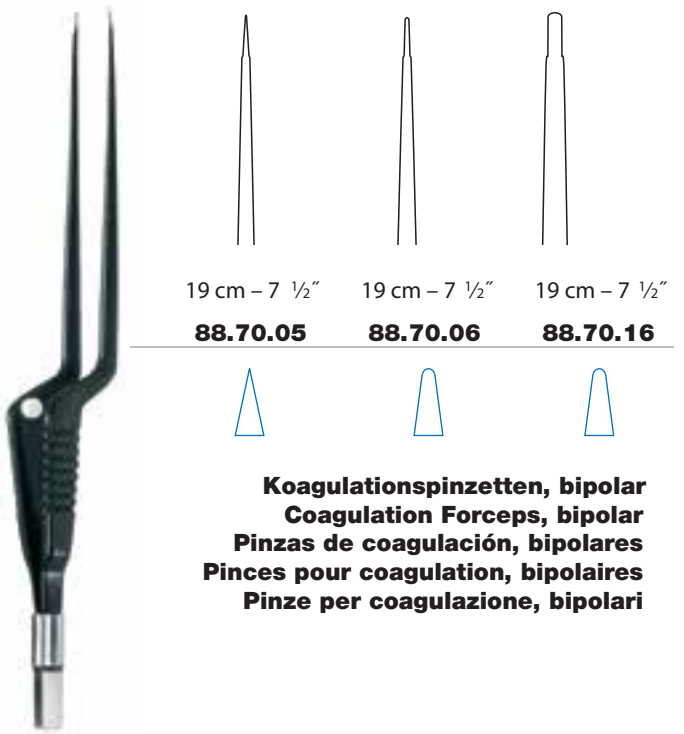

Koagulationspinzetten, bipolar
Coagulation Forceps, bipolar
Pinzas de coagulación, bipolares
Pinces pour coagulation, bipolaires
Pinze per coagulazione, bipolari

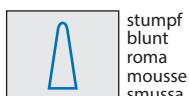
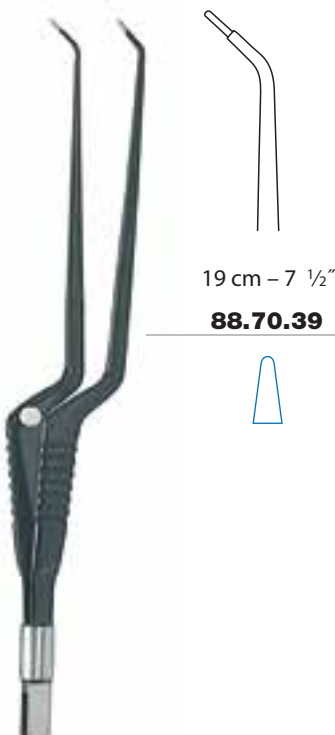



TREVALLi

Bipolare Antihft-Pinzetten
Bipolar Non-sticking Forceps
Pinzas bipolares no adherentes
Pinces bipolaires anti-adhésives
Pinze bipolari antiaderenti

Antihftbeschichtung sorgt für eine effektive Koagulation
Anti-stick coating assures an effective coagulation
El recubrimiento no adherente permite una coagulación efectiva
Grâce à ses pointes anti-adhésives, la pince bipolaire permet une meilleure coagulation
Il rivestimento antiaderente permette una coagulazione effettiva



- ▶ Kein Anhaften von Biogewebe
- ▶ Schnelle Wärme- und Stromableitung
- ▶ Einfache Reinigung

- ▶ No adhesion of biological tissue
- ▶ Quick discharge of heat and current
- ▶ Easy to clean

- ▶ Ninguna adherencia del tejido
- ▶ Derivación rápida del calor y corriente
- ▶ Mantenimiento fácil

- ▶ Les tissus ne restent pas collés à la pince
- ▶ Conductivité rapide et sûre de la chaleur et de l'électricité
- ▶ Entretien facile

- ▶ Nessuna adesione di tessuti
- ▶ Derivazione veloce di calore e corrente
- ▶ Pulizia facile



TREVALLi

Bipolare Antihaft-Pinzetten
Bipolar Non-sticking Forceps
Pinzas bipolares no adherentes
Pinces bipolaires anti-adhésives
Pinze bipolari antiaderenti

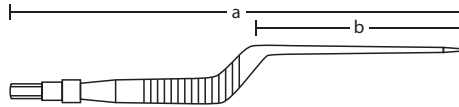

1:1.5



a = 15 cm - 6"	88.07.02		0,6 mm
a = 15 cm - 6"	88.07.03		1,0 mm
a = 18 cm - 7 1/8"	88.07.07		0,6 mm
a = 18 cm - 7 1/8"	88.07.08		1,0 mm
a = 20 cm - 8"	88.07.12		0,6 mm
a = 20 cm - 8"	88.07.13		1,0 mm

1:1.5



a = 20 cm - 8"	b = 10 cm - 4"	88.08.01		0,3 mm
a = 20 cm - 8"	b = 10 cm - 4"	88.08.02		0,6 mm
a = 20 cm - 8"	b = 10 cm - 4"	88.08.03		1,0 mm
a = 20 cm - 8"	b = 10 cm - 4"	88.08.04		1,3 mm
a = 20 cm - 8"	b = 10 cm - 4"	88.08.05		2,0 mm
a = 22 cm - 8 3/4"	b = 13 cm - 5 1/8"	88.08.06		0,3 mm
a = 22 cm - 8 3/4"	b = 13 cm - 5 1/8"	88.08.07		0,6 mm
a = 22 cm - 8 3/4"	b = 13 cm - 5 1/8"	88.08.08		1,0 mm
a = 22 cm - 8 3/4"	b = 13 cm - 5 1/8"	88.08.09		1,3 mm
a = 22 cm - 8 3/4"	b = 13 cm - 5 1/8"	88.08.10		2,0 mm
a = 24 cm - 9 1/2"	b = 15 cm - 6"	88.08.11		0,3 mm
a = 24 cm - 9 1/2"	b = 15 cm - 6"	88.08.12		0,6 mm
a = 24 cm - 9 1/2"	b = 15 cm - 6"	88.08.13		1,0 mm
a = 24 cm - 9 1/2"	b = 15 cm - 6"	88.08.14		1,3 mm
a = 24 cm - 9 1/2"	b = 15 cm - 6"	88.08.15		2,0 mm



TREVALLI

Koagulationselektroden, bipolar
Coagulation Electrodes, bipolar
Electrodos de coagulación, bipolares
Electrodes pour coagulation, bipolaires
Elettrodi per coagulazione, bipolari



Indikationen
 Indications
 Indicaciones
 Indications
 Indicazioni

Nutzlänge
 Working length
 Largo útil
 Longueur utile
 Lunghezza utile

Nasenmuschel Nasal concha Cornete nasal Conque nasale Cavità nasale	18,5 cm – 7 ¼" 88.90.20	11 cm – 4 ¾"	Binner 
---	-----------------------------------	--------------	---

Indikationen
 Indications
 Indicaciones
 Indications
 Indicazioni

Nutzlänge
 Working length
 Largo útil
 Longueur utile
 Lunghezza utile

Nase Nose Nariz Nez Naso	17 cm – 6 ¾" 88.90.10	8 cm – 3 ⅛"	Meuser 
Rachenmandeln Pharyngeal tonsils Amígdalas faríngeas Amygdales pharyngiennes Tonsille faringee	19 cm – 7 ½" 88.90.30	11 cm – 4 ¾"	Meuser 
Larynx Larynx Laringe Larynx Laringe	35 cm – 13 ¾" 88.90.40	27 cm – 10 ¾"	Binner 



TREVALLi

Anschlusskabel
Connecting Cables
Cables de conexión
Câbles connecteurs
Cavi di connessione

Stecker für Instrumente:
Connector for instruments:
Enchufe para instrumentos:
Fiche pour instruments:
Attacco per strumenti:

88.07.02-03
88.07.07-08
88.07.12-13
88.08.01-15













bipolar
bipolar
bipolar
bipolaire
bipolare



monopolar
monopolar
monopolar
monopolaire
monopolare

Stecker für Geräte von:
Connector for apparatus of:
Enchufe para equipos de:
Fiche pour appareils de:
Attacco per apparecchi:

	<<<<		3 m	87.30.96	ERBE MARTIN BERCHTOLD
	<<<<		3 m 5 m	88.00.20 88.00.21	Ø 12,5 mm ERBE STORZ
	<<<<		3 m 5 m	88.00.23 88.00.24	Ø 8 mm MARTIN BERCHTOLD AESCULAP WOLF
	<<<<		3 m 5 m	88.00.22 88.00.27	Ø 4 mm U.S. Standard ERBE ICC International
	<<<<		3 m 5 m	88.00.28 88.00.29	Ø 4 mm VALLEYLAB



TREVALLi

Halteklammer
Bracket
Dispositivo
Dispositif
Dispositivo

Halteklammer für ein Hochfrequenzkabel mit Knickschutz
Bracket for one high frequency cable with buckling resistance
Dispositivo para un cable de alta frecuencia con protección contra pliegues de cables
Dispositif pour un câble à haut fréquence avec protection contre plis de câble
Dispositivo per un cavo ad alta frequenza con protezione antipiega

- ▶ Passend für Siebkörbe ab ½-Container
- ▶ Sicherheitsverschluss dient auch als Haltegriff
- ▶ Verwendbar für alle Hochfrequenzkabel
- ▶ Suitable for wire baskets starting from ½ container
- ▶ Safety lock may serve as handle
- ▶ Suitable for all high frequency cables
- ▶ Aptos para bandejas a partir de ½ contenedor
- ▶ Cierre de seguridad sirve también de mango
- ▶ Utilizable para todos cables de alta frecuencia
- ▶ Approprié pour paniers à partir de ½ container
- ▶ Fermeur de sécurité utilisable comme manche
- ▶ Approprié pour tous types de câbles à haute fréquence
- ▶ Adatto a cestelli da ½ contenitore
- ▶ Chiusura di sicurezza utilizzabile come manico
- ▶ Adatto a tutti i cavi ad alta frequenza



22,5 cm - 9"

88.00.40



TREVALLi

ENT INSTRUMENTS

Siebvorschläge
Set Suggestions
Proposiciones de juegos
Propositions pour boîtes
Proposte di sets

trevalli@mweb.co.za



TREVALLi

Grundsieb
Basic Set
Juego básico
Boîte de base
Set di base

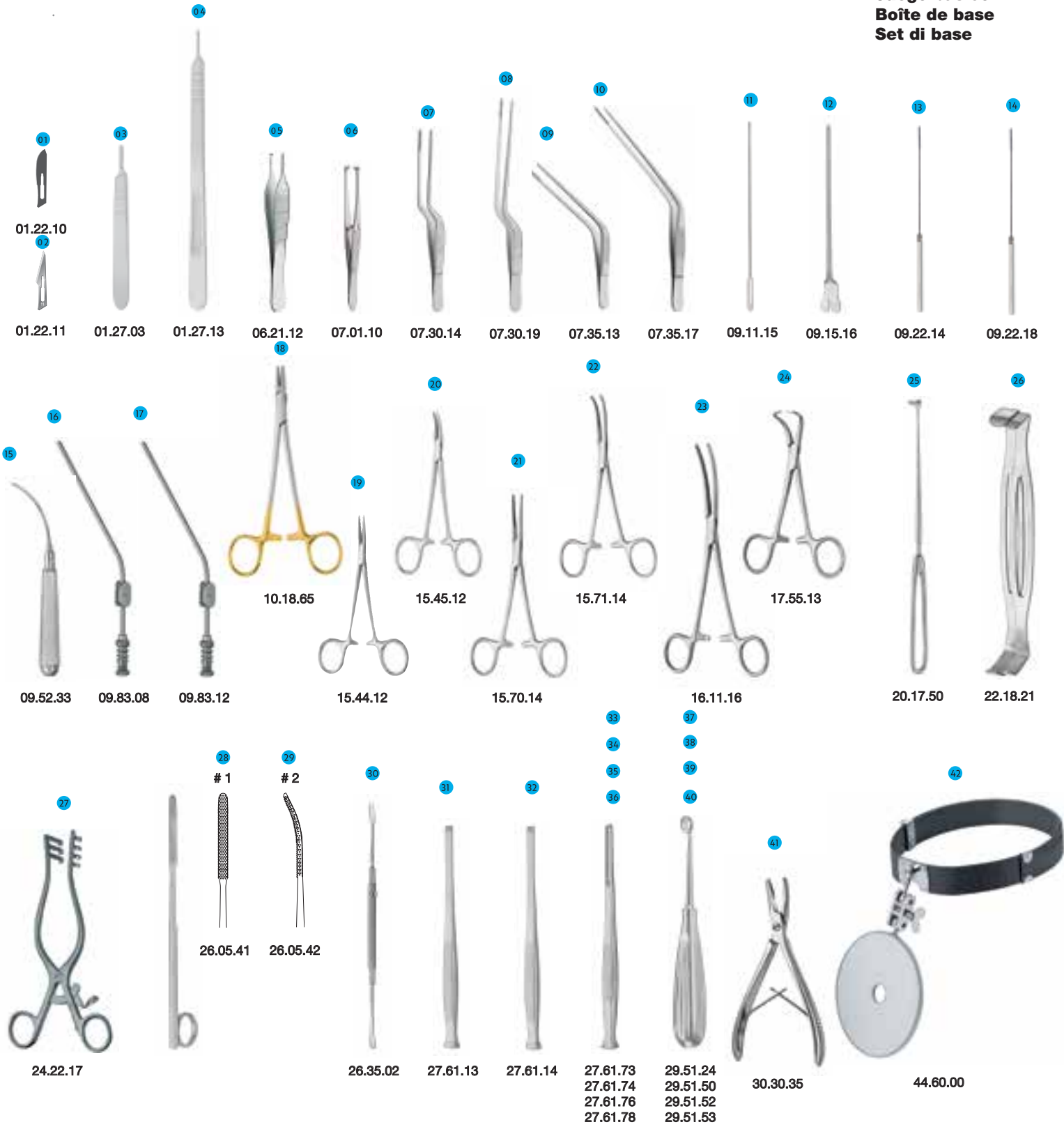



TREVALLi

Grundsieb
Basic Set
Juego básico
Boîte de base
Set di base

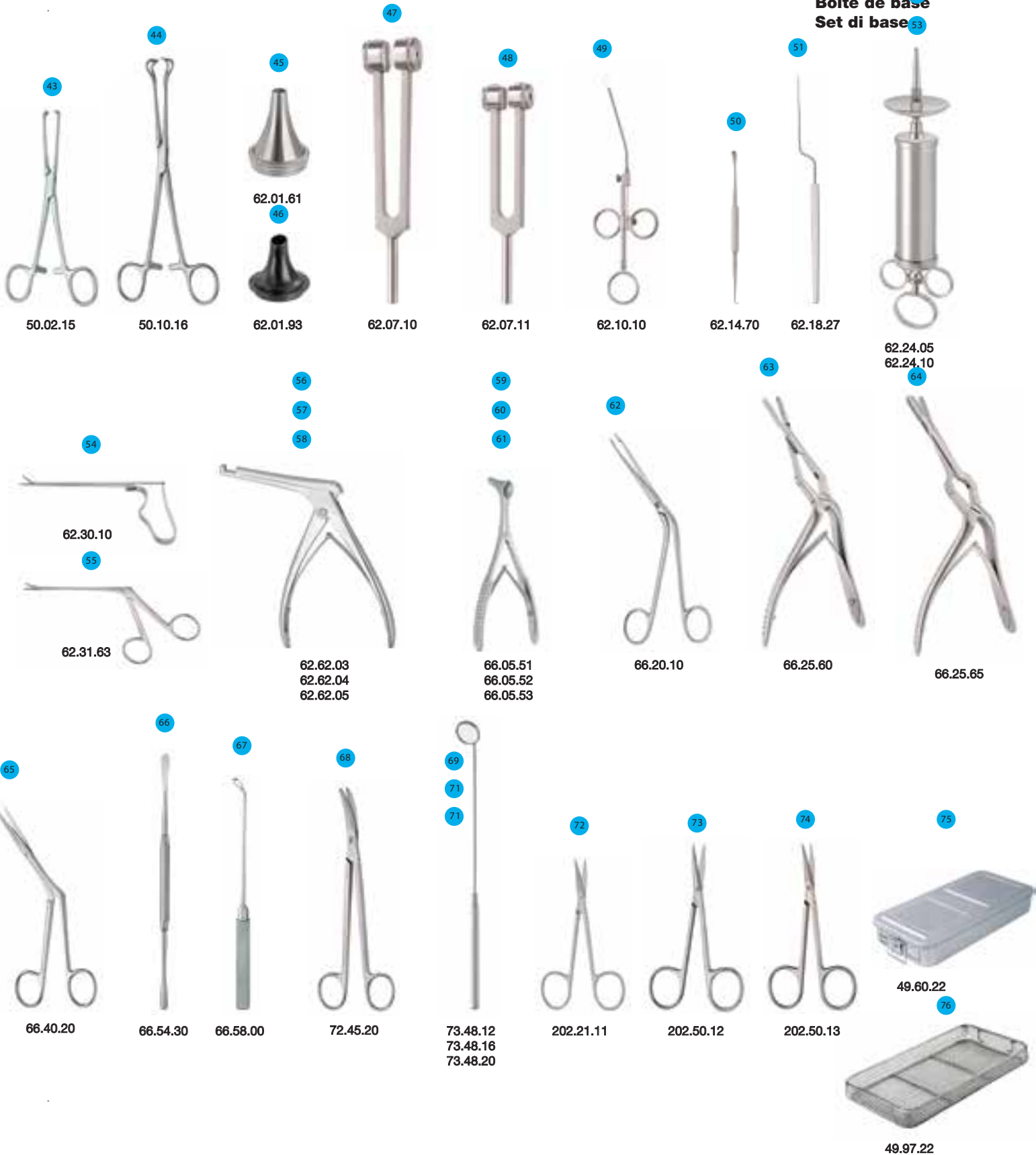



TREVALLi

Grundsieb
Basic Set
Juego básico
Boîte de base
Set di base

Part 1

SR	tem number	Description	Quantity
01	01 22 10	Scalpel blade · figure 10 · sterile · packing unit 100 pieces	1
02	01 22 11	Scalpel blade · figure 11 · sterile · packing unit 100 pieces	1
03	01 27 03	Scalpel handle · no. 3 · standard · 12,5 cm	1
04	01 27 13	Scalpel handle · no. 3L · long · 21 cm	1
05	06 21 12	ADSON Tissue forceps · 1 × 2 teeth · smooth · 12 cm	2
06	07 01 10	GRAEFE Fixation forceps · straight · with catch · 11 cm	2
07	07 30 14	LUCAE Bayonet forceps · serrated · 14 cm	1
08	07 30 19	GRUENWALD Bayonet forceps · serrated · 19,5 cm	2
09	07 35 13	TROELTSCH (WILDE) Ear forceps · serrated · 13 cm	1
10	07 35 17	TROELTSCH Nasal forceps · serrated · 17 cm	2
11	09 11 15	MOD. USA Probe · with eye · 15 cm	2
12	09 15 16	Grooved director · 16 cm	2
13	09 22 14	Cotton carrier · Ø 1,5 mm · serrated · 14 cm	2
14	09 22 18	Cotton carrier · Ø 1,5 mm · serrated · 18 cm	2
15	09 52 33	COAKLEY Antrum trocar · Ø 3 mm · 16 cm	1
16	09 83 08	FRAZIER Suction cannula · 8 French · angled · 12,5 cm	2
17	09 83 12	FRAZIER Suction cannula · 12 French · angled · 12,5 cm	1
18	10 18 65	MAYO-HEGAR HM Needle holder · 15 cm	1
19	15 44 12	HALSTED-MOSQUITO Hemostatic forceps · straight · 12,5 cm	6
20	15 45 12	HALSTED-MOSQUITO Hemostatic forceps · curved · 12,5 cm	6
21	15 70 14	KELLY Hemostatic forceps · straight · 14 cm	4
22	15 71 14	KELLY Hemostatic forceps · curved · 14 cm	4
23	16 11 16	ROCHESTER-PEAN Hemostatic forceps · curved · 16 cm	6
24	17 55 13	BACKHAUS Towel clamp · 13 cm	8
25	20 17 50	CUSHING Vein retractor · 8 × 10 mm · 21 cm	2
26	22 18 21	PARKER-LANGENBECK (US-ARMY) Retractor · double-ended · set/2 · 21 cm	1
27	24 22 17	WEITLANER Retractor · 3 × 4 teeth · blunt · 16,5 cm	1
28	26 05 41	GALLAHER Rasp · figure 1 · 19 cm	1
29	26 05 42	GALLAHER Rasp · figure 2 · 19 cm	1
30	26 35 02	FREER Elevator · sharp/blunt · 5 mm · 19 cm	1
31	27 61 13	PARTSCH Chisel · 3 mm · 17 cm	1
32	27 61 14	PARTSCH Chisel · 4 mm · 17 cm	1
33	27 61 73	PARTSCH Gouge · 3 mm · 17 cm	1
34	27 61 74	PARTSCH Gouge · 4 mm · 17 cm	1
35	27 61 76	PARTSCH Gouge · 6 mm · 17 cm	1
36	27 61 78	PARTSCH Gouge · 8 mm · 17 cm	1
37	29 51 24	VOLKMANN Sharp curette · figure 4/0 · 17 cm	1
38	29 51 50	VOLKMANN Sharp curette · figure 0 · 17 cm	1
39	29 51 52		1
40	29 51 53	VOLKMANN Sharp curette · figure 3 · 17 cm	1
41	30 30 35	LUER Bone rongeur · curved · 15 cm	1
42	44 60 00	ZIEGLER Head mirror · Ø 90 mm · complete	2



Part 2

SR	Item number	Description	Quantity
43	50.02.15	ALLIS Grasping forceps · 4 x 5 teeth · 15 cm	4
44	50.10.16	BABCOCK Grasping forceps · 16 cm	4
45	62.01.61	BOUCHERON Ear specula · set/4	1
46	62.01.93	Delrin ear speculum · Ø 3 mm	1
47	62.07.10	Tuning fork · aluminium · c - 128	1
48	62.07.11	Tuning fork · aluminium · c ¹ - 256	1
49	62.10.10	KRAUSE Ear polypus snare · 16 cm	1
50	62.14.70	GROSS Ear spoon and hook · 12 cm	2
51	62.18.27	LUCAE (ROYCE) Tympanum perforator · bayonet · 18 cm	1
52	62.24.05	All metal ear syringe · 50 ml	1
53	62.24.10	All metal ear syringe · 100 ml	1
54	62.30.10	MEDICON Foreign body forceps · 13 cm	1
55	62.31.63	HARTMANN Ear forceps · 1 x 2 teeth · 8 cm	2
56	62.62.03	KERRISON Mastoid Rongeur · fi gure 0 - 3 mm · 8 cm	1
57	62.62.04	KERRISON Mastoid Rongeur · fi gure 1 - 4 mm · 8 cm	1
58	62.62.05	KERRISON Mastoid Rongeur · fi gure 2 - 5 mm · 8 cm	2
59	66.05.51	MOD. WIEN Nasal speculum · fi gure 1 · 14 cm	2
60	66.05.52	MOD. WIEN Nasal speculum · fi gure 2 · 14 cm	2
61	66.05.53	MOD. WIEN Nasal speculum · fi gure 3 · 14 cm	2
62	66.20.10	HARTMANN Nasal dressing forceps · 18 cm	2
63	66.25.60	JANSEN-MIDDLETON Nasal septum forceps · 19 cm	1
64	66.25.65	JANSEN-MIDDLETON Nasal septum rongeur · 19 cm	1
65	66.40.20	HEYMANN Nasal scissors · 17 cm	1
66	66.54.30	HAJEK-BALLENGER Septum elevator · double-ended · 20 cm	1
67	66.58.00	COAKLEY Antrum curettes · set /6	1
68	72.45.20	PRINCE Tonsil scissors · 18 cm	2
69	73.48.12	Laryngeal mirror · fi gure 1 - Ø 12 mm · 22 cm	2
70	73.48.16	Laryngeal mirror · fi gure 3 - Ø 16 mm · 22 cm	2
71	73.48.20	Laryngeal mirror · fi gure 5 - Ø 20 mm · 22 cm	2
72	202.21.11	Iris scissors · supercut · curved · 11,5 cm	2
73	202.50.12	STEVENS Scissors · supercut · straight · blunt · 11,5 cm	2
74	202.50.13	STEVENS Scissors · supercut · curved · blunt · 11,5 cm	2
75	49.60.22	Medicontainer · 590 x 290 x 220 mm · silver	1
76	49.97.22	Wire basket · 510 x 255 x 70 mm	2



TREVALLi

**Tracheotomiesieb
Tracheotomy Set
Juego para traqueostomia
Boîte pour trachéotomie
Set per tracheotomia**

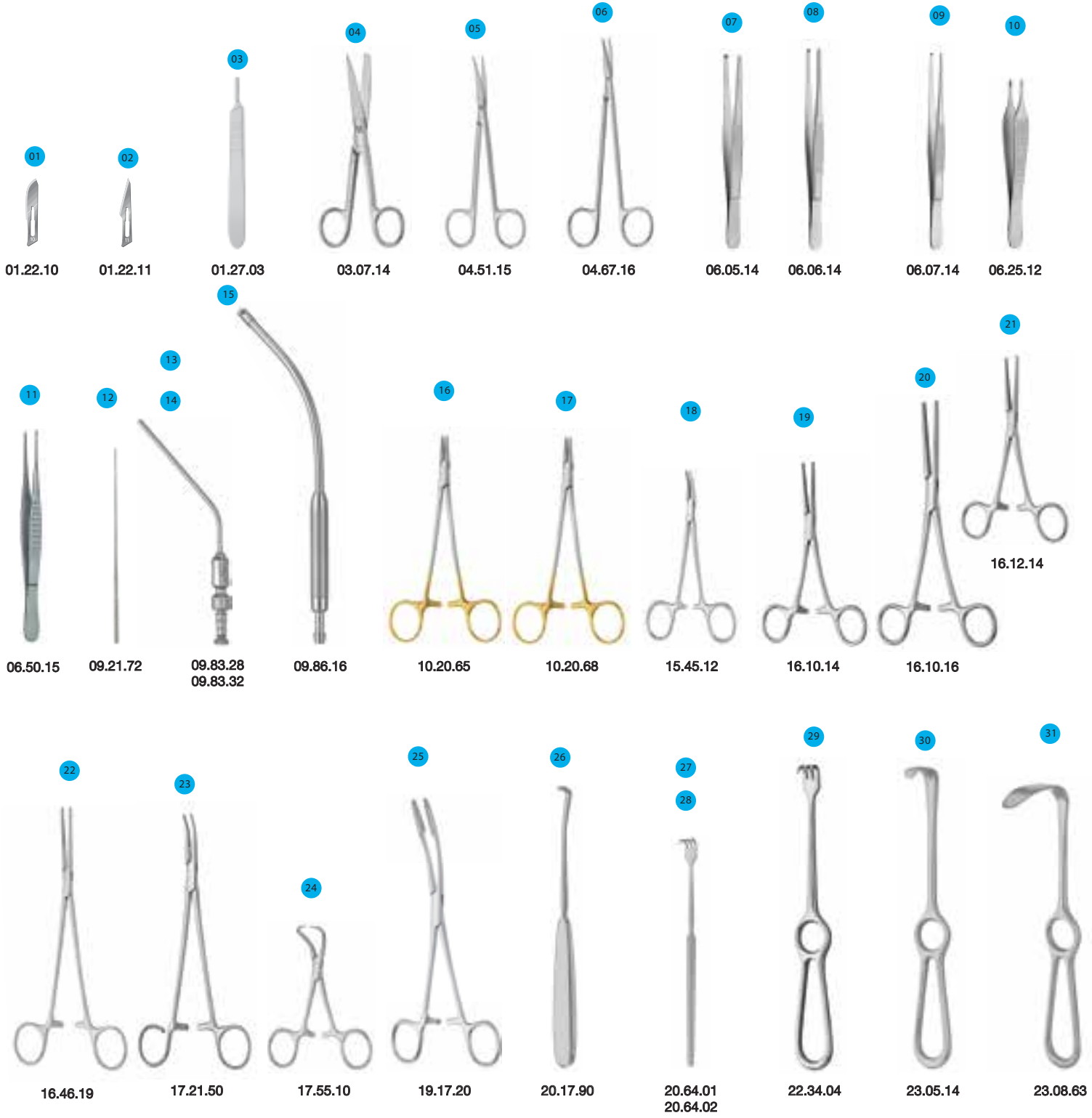



TREVALLi

Tracheotomiesieb
Tracheotomy Set
Juego para traqueostomia
Boîte pour trachéotomie
Set per tracheotomia

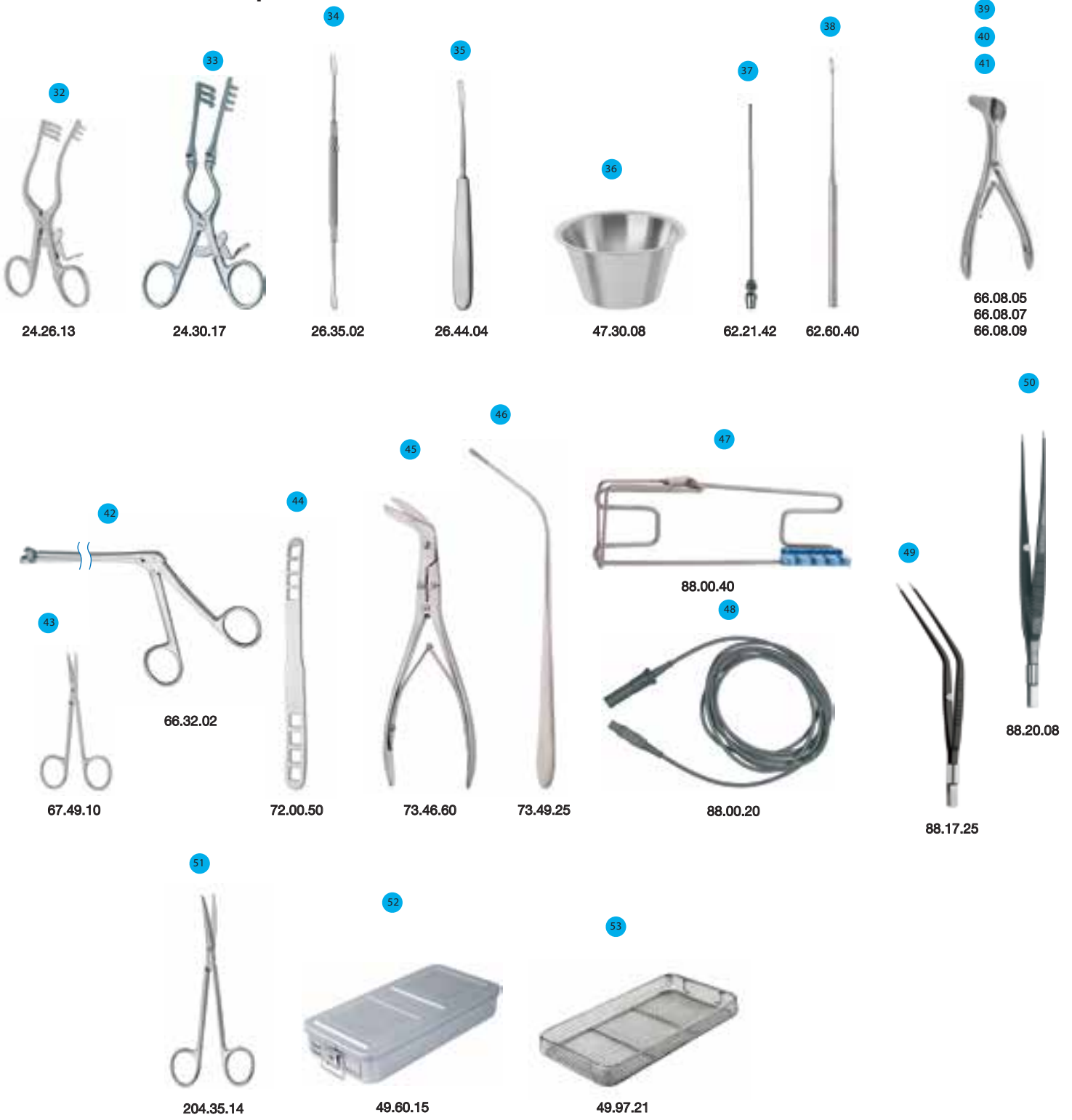



Part 1

SR	Item number	Description	Quantity
01	01.22.10	Scalpel blade · figure 10 · sterile · packing unit 100 pieces	1
02	01.22.11	Scalpel blade · figure 11 · sterile · packing unit 100 pieces	1
03	01.27.03	Scalpel handle · no. 3 · standard · 12,5 cm	1
04	03.07.14	Operating scissors · curved · sharp/blunt · 14,5 cm	1
05	04.51.15	JOSEPH Scissors · curved · 15 cm	1
06	04.67.16	REYNOLDS (JAMESON) Scissors · curved · 16 cm	1
07	06.05.14	Tissue forceps · 1 × 2 teeth · standard · 14,5 cm	2
08	06.06.14	Tissue forceps · 1 × 2 teeth · medium · 14,5 cm	1
09	06.07.14	Tissue forceps · 1 × 2 teeth · slim · 14,5 cm	1
10	06.25.12	ADSON-BROWN Tissue forceps · straight · 7 × 7 teeth · 12 cm	1
11	06.50.15	DEBAKEY AT Vascular forceps · 1,5 mm · 15 cm	1
12	09.21.72	Cotton carrier · Ø 1,2 mm · triangular serrated · 12 cm	2
13	09.83.28	FRAZIER (FERGUSSON) Suction cannula · 8 French · angled · 12,5 cm	1
14	09.83.32	FRAZIER (FERGUSSON) Suction cannula · 12 French · angled · 12,5 cm	1
15	09.86.16	COOLEY Suction tube · Ø 9 mm · 30 cm	1
16	10.20.65	CRILE-WOOD HM (DEBAKEY HM) Needle holder · 15 cm	1
17	10.20.68	CRILE-WOOD HM (DEBAKEY HM) Needle holder · 18 cm	1
18	15.45.12	HALSTED-MOSQUITO Hemostatic forceps · curved · 12,5 cm	8
19	16.10.14	PEAN Hemostatic forceps · straight · 14 cm	2
20	16.10.16	ROCHESTER-PEAN Hemostatic forceps · straight · 16 cm	1
21	16.12.14	KOCHER Hemostatic forceps · straight · 1 × 2 teeth · 14 cm	2
22	16.46.19	BIRKETT Hemostatic forceps · straight · 19 cm	1
23	17.21.50	SCHNIDT (BOETTCHER) Dissecting forceps · slightly curved · 19 cm	2
24	17.55.10	BACKHAUS Towel clamp · 10,5 cm	6
25	19.17.20	GROSS Dressing forceps · curved · 20 cm	1
26	20.17.90	SCHOENBORN Retractor · 6 × 13 mm · 21 cm	1
27	20.64.01	Tracheal retractor · 1 tooth · sharp · 16 cm	1
28	20.64.02	Tracheal retractor · 2 teeth · sharp · 8 mm · 16 cm	1
29	22.34.04	VOLKMANN Retractor · 4 teeth · sharp · 18 mm · 22 cm	2
30	23.05.14	LANGENBECK Retractor · 14 × 28 mm · 21 cm	2
31	23.08.63	LANGENBECK Retractor · 20 × 63 mm · 21 cm	2

Part 2 ▶



TREVALLi

**Tracheotomiesieb
Tracheotomy Set
Juego para traqueostomia
Boîte pour trachéotomie
Set per tracheotomia**

Part 2

SR	Item number	Description	Quantity
32	24.26.13	WEITLANER-WULLSTEIN Retractor · sharp · 13 cm	1
33	24.30.17	WEITLANER-BECKMANN Retractor · blunt · 17 cm	1
34	26.35.02	FREER Elevator · sharp/blunt · 5 mm · 19 cm	1
35	26.44.04	JOSEPH Raspatory · 4 mm · 16,5 cm	1
36	47.30.08	Round bowl · 80 x 35 mm · 0,1 l	1
37	62.21.42	WULLSTEIN Suction tube · Ø 2,0 mm · sterling silver · 16 cm	1
38	62.60.40	WULLSTEIN Raspatory · 17 cm	1
39	66.08.05	KILLIAN Nasal speculum · figure 2 · 50 mm · 14 cm	1
40	66.08.07	KILLIAN Nasal speculum · figure 3 · 75 mm · 14 cm	1
41	66.08.09	KILLIAN Nasal speculum · figure 4 · 90 mm · 14 cm	1
42	66.32.02	HARTMANN Nasal forceps through-cutting · figure 2 · 12 cm	1
43	67.49.10	COTTLE-MASING Nasal scissors · curved · blunt · 10 cm	1
44	72.00.50	BRÜNING'S Tongue depressor · 14/18 mm · 19 cm	1
45	73.46.60	KILLIAN Laryngeal scissors · 20 cm	1
46	73.49.25	KILLIAN Cotton carrier · 25 cm	1
47	88.00.20	Bipolar connecting cable · Ø 12,5 mm · 3 m	1
48	88.00.40	Bracket	1
49	88.17.25	Coagulation forceps · bipolar · angled · sharp · 16,5 cm	1
50	88.20.08	Coagulation forceps · bipolar · angled · blunt · 20 cm	1
51	204.35.14	METZENBAUM SLIM Scissors · supercut · curved · 14 cm	1
52	49.60.15	Medicontainer · 590 x 290 x 150 mm · silver	1
53	49.97.21	Wire basket · 510 x 255 x 50 mm	2



TREVALLi

Tonsillektomie- und Adenotomiesieb
Tonsillectomy and Adenoidectomy Set
Juego para amigdalectomia y adenotomia
Boîte pour amygdalectomie et adénoïdectomie
Set per tonsillectomia e adenotomia

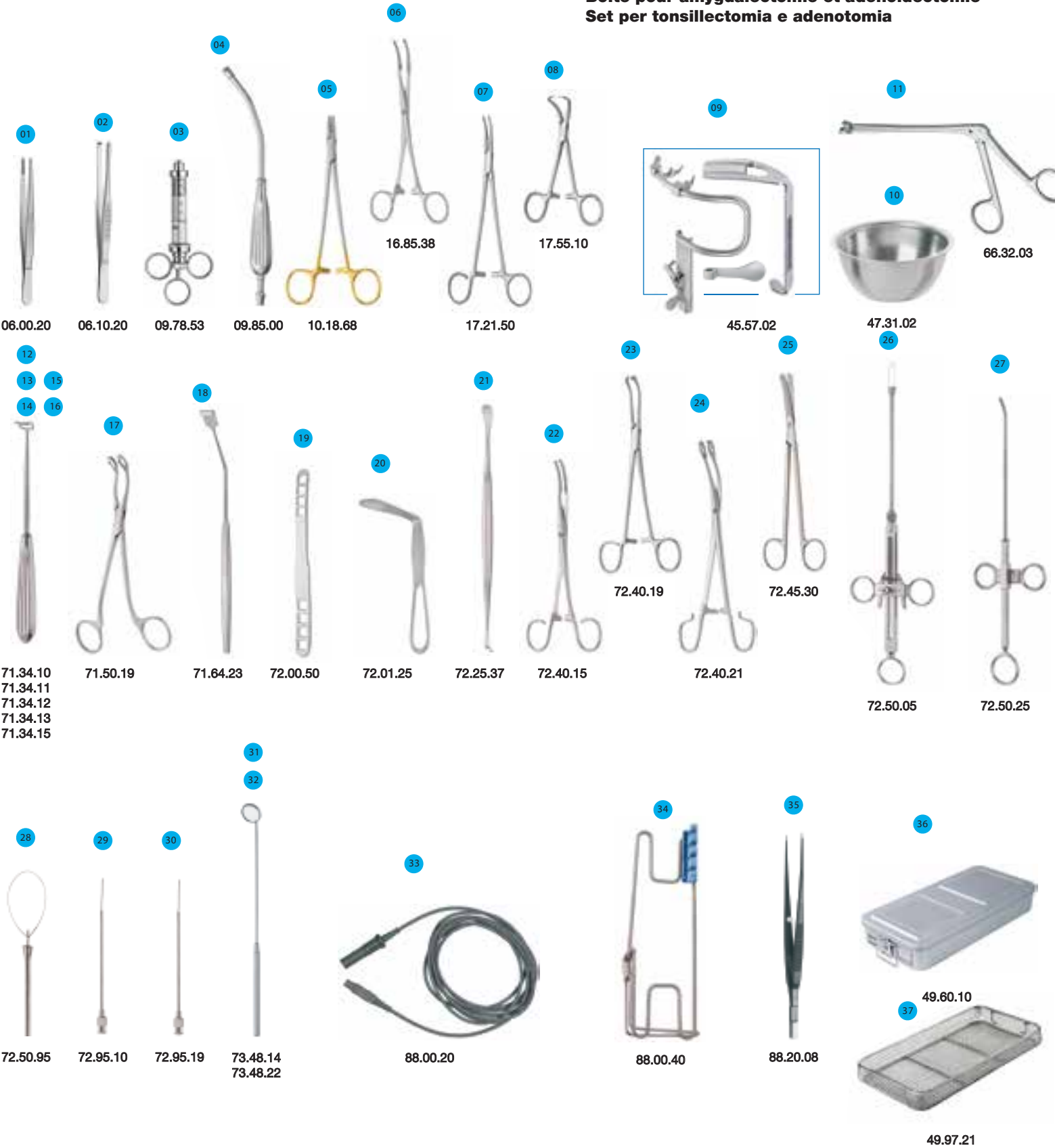

01

02

03

04

05

06

07

08

09

11

10

12

13

15

14

16

17

18

19

20

21

22

23

24

25

26

27

31

32

28

29

30

33

34

35

36

37

06.00.20

06.10.20

09.78.53

09.85.00

10.18.68

16.85.38

17.21.50

17.55.10

45.57.02

47.31.02

66.32.03

71.34.10

71.34.11

71.34.12

71.34.13

71.34.15

71.50.19

71.64.23

72.00.50

72.01.25

72.25.37

72.40.15

72.40.19

72.45.30

72.50.05

72.50.25

72.50.95

72.95.10

72.95.19

73.48.14

73.48.22

88.00.20

88.00.40

88.20.08

49.60.10

49.97.21



TREVALLi

Tonsillektomie- und Adenotomiesieb
Tonsillectomy and Adenoïdectomy Set
Juego para amigdalectomia y adenotomia
Boîte pour amygdalectomie et adénoïdectomie
Set per tonsillectomia e adenotomia

SR	Item number	Description	Quantity
01	06.00.20	Dressing forceps · standard · 20 cm	1
02	06.10.20	Tissue forceps · 2 x 3 teeth · 20 cm	1
03	09.78.53	Hypodermic syringe · 5 ml · Luer-Lock	1
04	09.85.00	YANKAUER Suction tube · 28 cm	1
05	10.18.68	MAYO-HEGAR HM Needle holder · 18 cm	1
06	16.85.38	MIKULICZ Peritoneum forceps · 18 cm	1
07	17.21.50	SCHNIDT (BOETTCHER) Dissecting forceps · slightly curved · 19 cm	1
08	17.55.10	BACKHAUS Towel clamp · 10,5 cm	6
09	45.57.02	KILNER-DOUGHTY Mouth gag · complete	1
10	47.31.02	Round bowl · Ø 60 mm · height 30 mm · 0,06 l	1
11	66.32.03	HARTMANN Nasal forceps through-cutting · 12 cm · figure 3	1
12	71.34.10	BECKMANN Adenoid curette 21,5 cm · figure 1 - 10 mm	1
13	71.34.11	BECKMANN Adenoid curette 21,5 cm · figure 2 - 11 mm	1
14	71.34.12	BECKMANN Adenoid curette 21,5 cm · figure 3 - 12 mm	1
15	71.34.13	BECKMANN Adenoid curette 21,5 cm · figure 4 - 13 mm	1
16	71.34.15	BECKMANN Adenoid curette 21,5 cm · figure 5 - 15 mm	1
17	71.50.19	JURASZ Adenoid forceps · 19 cm	1
18	71.64.23	NAGER Soft palate retractor · 22 cm	1
19	72.00.50	BRÜNINGS Tongue depressor · 14/18 mm · 19 cm	1
20	72.01.25	HARTMANN Tongue depressor · 75 mm · 23 mm	1
21	72.25.37	HENKE Tonsil dissector · double-ended · 24 cm	1
22	72.40.15	MIKULICZ Tonsil forceps · 18 cm	1
23	72.40.19	COLVER Tonsil seizing forceps · 19 cm	1
24	72.40.21	BLOHMKE Tonsil seizing forceps · 21 cm	1
25	72.45.30	GOOD Tonsil scissors · 19 cm	1
26	72.50.05	BRÜNINGS Tonsil snare · 29 cm	1
27	72.50.25	ROEDER Mod. E · Tonsil snare · 27 cm	1
28	72.50.95	Wire loops · soldered · packing unit 100 pieces	1
29	72.95.10	Tonsil cannula Ø 0,8 mm · straight · Luer-Lock · 12 cm	1
30	72.95.19	Tonsil cannula Ø 0,8 mm · 90° angled · Luer-Lock · 12 cm	1
31	73.48.14	Laryngeal mirror · figure 2 - Ø 14 mm · 22 cm	1
32	73.48.22	Laryngeal mirror · figure 6 - Ø 22 mm · 22 cm	1
33	88.00.20	Bipolar connecting cable · Ø 12,5 mm · 3 m	1
34	88.00.40	Bracket · for high frequency cables · 22,5 cm	1
35	88.20.08	Coagulation forceps · bipolar · angled · blunt · 20 cm	1
36	49.60.10	Mediccontainer · 590 x 290 x 100 mm · silver	1
37	49.97.21	Wire basket · 510 x 255 x 50 mm	1



TREVALLI

- 01
- 02
- 03
- 04
- 05
- 06
- 07
- 08
- 09
- 10
- 11

Laryngoskopiesieb für Erwachsene
Laryngoscopy Set for Adults
Juego laringoscopia para adultos
Boîte laryngoscopie pour adultes
Set laringoscopia per adulti

12

-  73.17.01
-  73.17.02
-  73.17.03
-  73.17.04
-  73.17.09
-  73.17.21
-  73.17.33
-  73.17.35
-  73.17.36
-  73.17.38
-  73.30.80



18

17

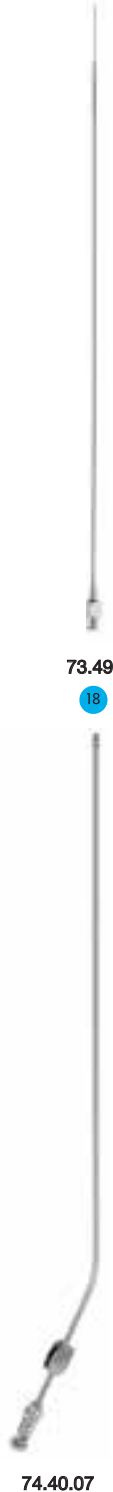



TREVALLi

- 19
- 20
- 21
- 22
- 23
- 24
- 25



74.47.10
74.47.13
74.47.14
74.47.25
74.47.27
74.47.28
74.47.35



74.47.37



74.47.42



74.47.90



88.00.40



88.00.20



88.90.40

Laryngoskopiesieb für Erwachsene
Laryngoscopy Set for Adults
Juego laringoscopia para adultos
Boîte laryngoscopie pour adultes
Set laringoscopia per adulti



49.60.13



49.97.12



49.97.82



TREVALLi

Laryngoskopiesieb für Erwachsene
Laryngoscopy Set for Adults
Juego laringoscopia para adultos
Boîte pour laryngoscopie pour adultes
Set per laringoscopia per adulti

Part 1

SR	Item number	Description	Quantity
01	73.17.01	Laryngeal cup forceps · Ø 2 mm · straight · 23 cm	1
02	73.17.02	Laryngeal cup forceps · Ø 2 mm · curved up · 23 cm	1
03	73.17.03	Laryngeal cup forceps · Ø 2 mm · curved right · 23 cm	1
04	73.17.04	Laryngeal cup forceps · Ø 2 mm · curved left · 23 cm	1
05	73.17.09	Laryngeal cup forceps · oval · 3 × 5 mm · straight · 23 cm	1
06	73.17.21	Laryngeal grasping forceps · serrated · straight · 23 cm	1
07	73.17.33	Laryngeal scissors · curved left · 23 cm	1
08	73.17.35	Laryngeal scissors · straight · 23 cm	1
09	73.17.36	Laryngeal scissors · 45° curved up · 23 cm	1
10	73.17.38	Laryngeal scissors · curved right · 23 cm	1
11	73.30.80	Laryngeal needle holder · with catch · conical · 23 cm	1
12	73.49.77	Laryngeal needle · bayonet · Luer-Lock · 27,5 cm	1
13	74.00.03	Operating laryngoscope · figure 3 · 182 mm	1
14	74.00.04	Operating laryngoscope · figure 4 · 172 mm	1
15	74.00.05	Operating laryngoscope · figure 5 · 172 mm	1
16	74.01.01	Laryngoscope holder · with chest support	1
17	74.01.04	Fibre optic light carrier	1
18	74.40.07	TORRINGTON Suction tube · 7 French	1

Part 2 ▶



TREVALLi

Laryngoskopiesieb für Erwachsene
Laryngoscopy Set for Adults
Juego laringoscopia para adultos
Boîte pour laryngoscopie pour adultes
Set per laringoscopia per adulti

Part 2

SR	Item number	Description	Quantity
19	74.47.10	Endolaryngeal sickle knife · 24 cm	1
20	74.47.13	Endolaryngeal knife · golf club design · 24 cm	1
21	74.47.14	Endolaryngeal round edge knife · 24 cm	1
22	74.47.25	Endolaryngeal hook · 24 cm	1
23	74.47.27	Endolaryngeal needle · curved right · 24 cm	1
24	74.47.28	Endolaryngeal needle · curved left · 24 cm	1
25	74.47.35	Endolaryngeal hook · 24 cm	1
26	74.47.37	Endolaryngeal suction raspatory · 24 cm	1
27	74.47.42	Endolaryngeal knot guide · 24 cm	1
28	74.47.90	Handle	1
29	88.00.20	Bipolar connecting cable · Ø 12,5 mm · 3 m	1
30	88.00.40	Bracket · for high frequency cables · 22,5 cm	1
31	88.90.40	BINNER Larynx coagulation electrode · curved · 35 cm	1
32	49.60.13	Medicontainer · 590 × 290 × 135 mm · silver	1
33	49.97.12	Wire basket · 480 × 255 × 50 mm	2
34	49.97.82	Silicone mat · 13 mm · 467 × 240 mm	1



TREVALLi

Laryngoskopiesieb für Kinder
Paediatric Laryngoscopy Set
Juego laringoscopia para pediatria
Boîte pour laryngoscopie pour enfants
Set per laringoscopia pediatrica

01

02



73.17.80

73.17.81



73.18.00

73.18.01

73.18.06

73.18.07

73.18.09

73.18.10

73.18.11

03 04 05 06
07 08 09



10 11

13



74.00.01
74.00.02

74.01.03

12



74.01.02

14

74.01.08



15



49.60.10

16



49.97.12

17



49.97.82



TREVALLi

Laryngoskopiesieb für Kinder
Paediatric Laryngoscopy Set
Juego laringoscopia para pediatria
Boîte pour laryngoscopie pour enfants
Set per laringoscopia pediatrica

SR	Item number	Description	Quantity
01	73.17.80	Laryngeal suction tube · curved up · Ø 2 mm · 25 cm	1
02	73.17.81	Laryngeal suction tube · curved up · Ø 3 mm · 25 cm	1
03	73.18.00	Laryngeal cup forceps · Ø 2 mm · straight · 18 cm	1
04	73.18.01	Laryngeal cup forceps · Ø 2 mm · curved up · 18 cm	1
05	73.18.06	Laryngeal grasping forceps · serrated · straight · 18 cm	1
06	73.18.07	Laryngeal scissors · straight · 18 cm	1
07	73.18.09	Laryngeal scissors · curved right · 18 cm	1
08	73.18.10	Laryngeal scissors · curved left · 18 cm	1
09	73.18.11	Laryngeal cup forceps · Ø 4 mm · horizontal opening · 18 cm	1
10	74.00.01	Operating laryngoscope · fibre 1 · 135 mm	1
11	74.00.02	Operating laryngoscope · fibre 2 · 152 mm	1
12	74.01.02	Chest support · only	1
13	74.01.03	Fibre optic light carrier	1
14	74.01.08	Laryngoscope holder · only	1
15	49.60.10	Mediccontainer · 590 × 290 × 100 mm · silver	1
16	49.97.12	Wire basket · 480 × 255 × 50 mm	1
17	49.97.82	Silicone mat · 13 mm · 467 × 240 mm	1



TREVALLi

Weichteilsieb
Soft Tissue Set
Juego para partes blandas
Boîte pour parties molles
Set per parti molle

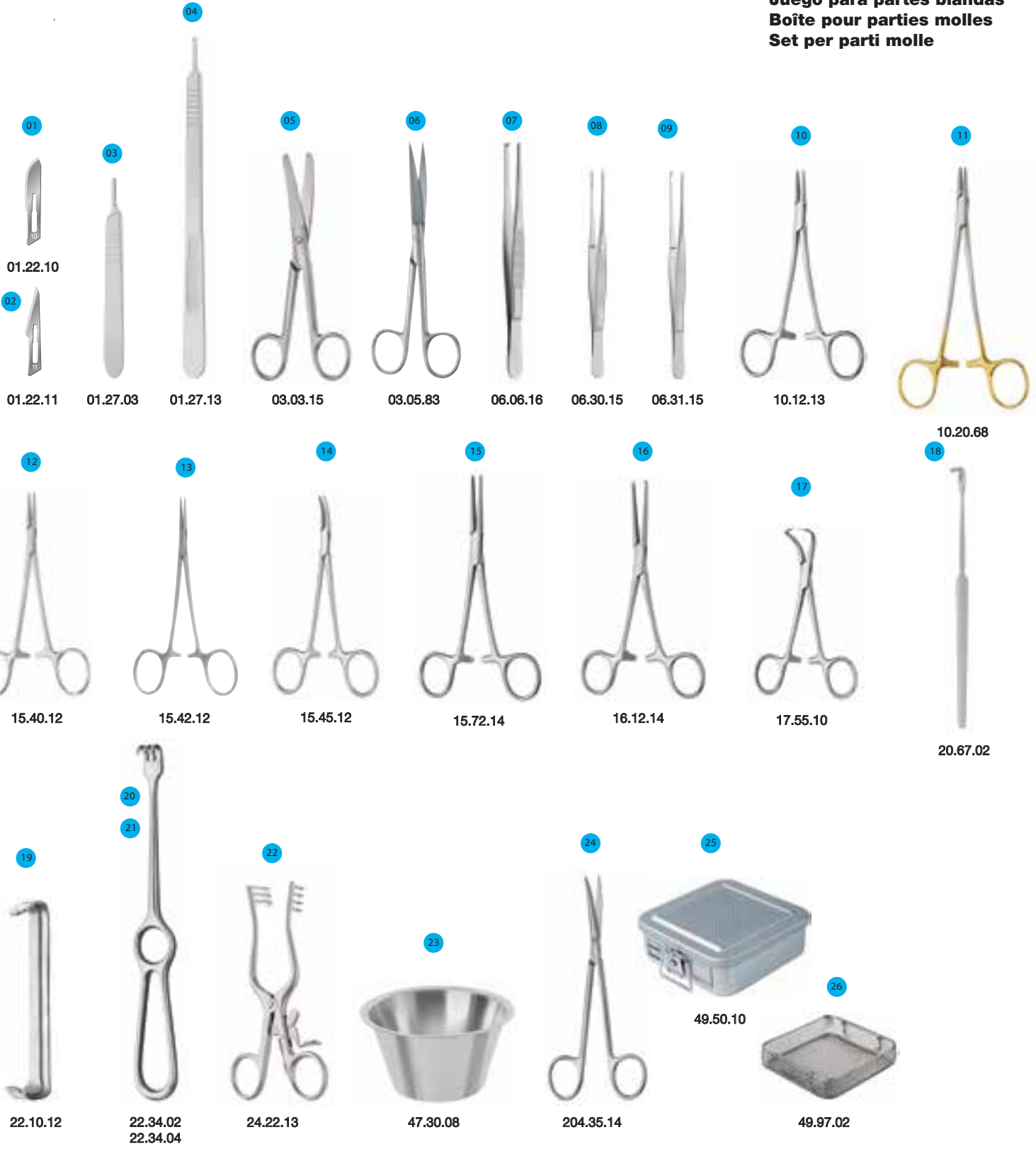



TREVALLi

Weichteilsieb
Soft Tissue Set
Juego para partes blandas
Boîte pour parties molles
Set per parti molle

SR	Item number	Description	Quantity
01	01.22.10	Scalpel blade · figure 10 · sterile · packing unit 100 pieces	1
02	01.22.11	Scalpel blade · figure 11 · sterile · packing unit 100 pieces	1
03	01.27.03	Scalpel handle · no. 3 · standard · 12,5 cm	1
04	01.27.13	Scalpel handle · no. 3L · long · 21 cm	1
05	03.03.15	Operating scissors · curved · blunt/blunt · 15 cm	1
06	03.05.83	Operating scissors · delicate · curved · sharp/sharp · 13 cm	1
07	06.06.16	Tissue forceps · medium · 1 x 2 teeth · 16 cm	1
08	06.30.15	SEMKEN Dressing forceps · straight · serrated · 15 cm	2
09	06.31.15	SEMKEN Tissue forceps · straight · 1 x 2 teeth · 15 cm	2
10	10.12.13	HALSEY Needle holder · serrated · 13,5 cm	1
11	10.20.68	CRILE-WOOD HM (DEBAKEY HM) Needle holder · 18 cm	1
12	15.40.12	MICRO-HALSTED Hemostatic forceps · straight · 12,5 cm	2
13	15.42.12	MICRO-HALSTED Hemostatic forceps · 1 x 2 teeth · straight · 12,5 cm	2
14	15.45.12	HALSTED-MOSQUITO Hemostatic forceps · curved · 12,5 cm	2
15	15.72.14	CRILE Hemostatic forceps · straight · 14 cm	2
16	16.12.14	KOCHER Hemostatic forceps · straight · 1 x 2 teeth · 14 cm	2
17	17.55.10	BACKHAUS Towel clamp · 10,5 cm	4
18	20.67.02	Tracheal retractor · 2 teeth · blunt · 5 mm · 16 cm	2
19	22.10.12	FARABEUF-BABY Retractor · set/2 · 12 cm	2
20	22.34.02	VOLKMANN Retractor · 2 teeth · sharp · 9 mm · 22 cm	1
21	22.34.04	VOLKMANN Retractor · 4 teeth · sharp · 18 mm · 22 cm	2
22	24.22.13	WEITLANER Retractor · 3 x 4 teeth · sharp · 13 cm	1
23	47.30.08	Round bowl · Ø 80 mm · height 35 mm · 0,1 l	1
24	204.35.14	METZENBAUM-SLIM Scissors · supercut · curved · 14 cm	1
25	49.50.10	Medicontainer · 290 x 290 x 100 mm · silver	1
26	49.97.02	Wire basket · 240 x 255 x 50 mm	1



TREVALLi

**Rhinoplastiksieb
Rhinoplasty Set
Juego para rinoplastia
Boîte pour rhinoplastie
Set per rinoplastica**

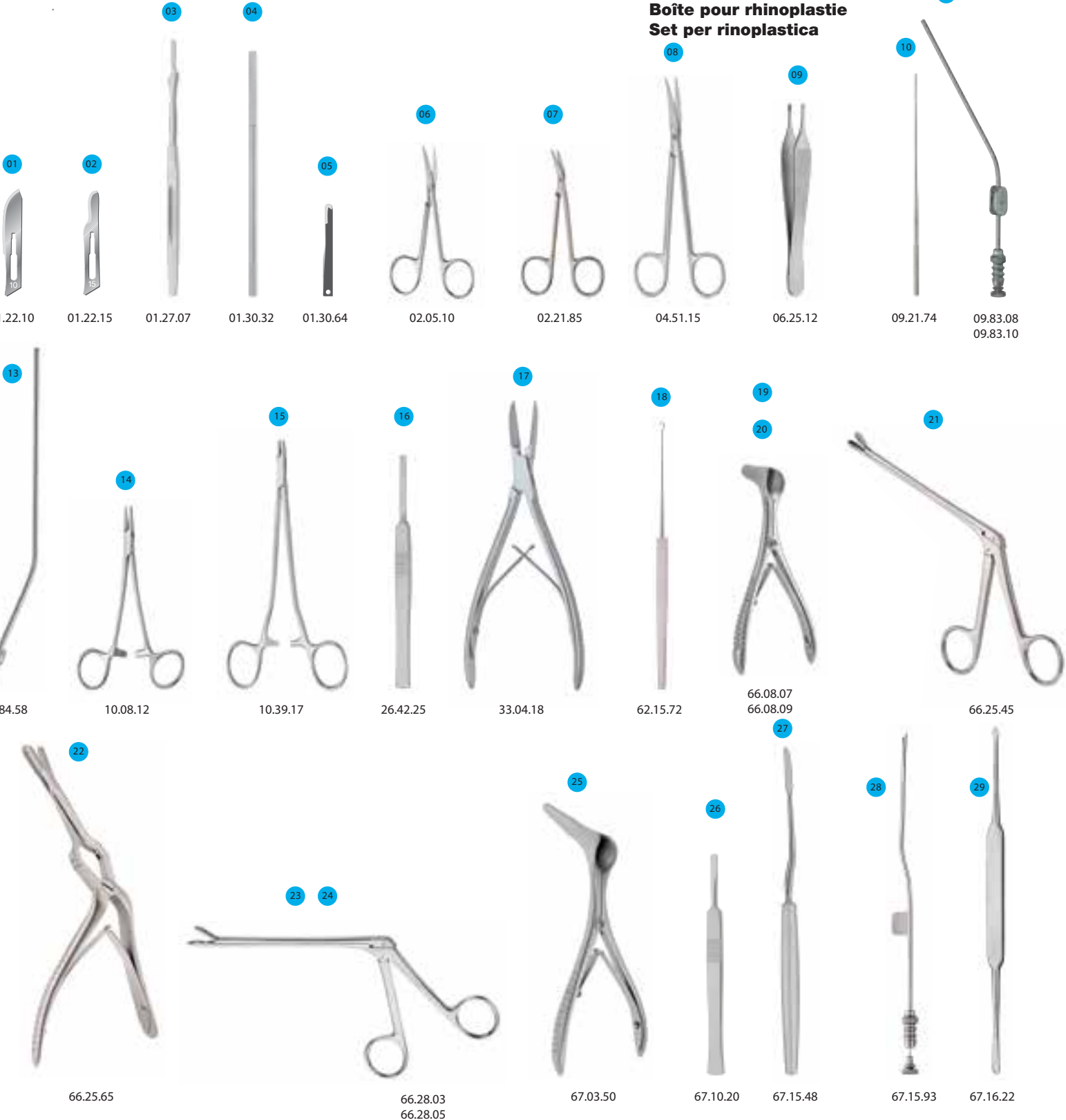



TREVALLI

Rhinoplastikieseb
Rhinoplasty Set
Juego para rinoplastia
Boîte pour rhinoplastie
Set per rinoplastica

30



67.16.65

31



67.19.70

32



67.20.21
67.20.22

34



67.20.50

35



67.20.51

36



67.21.15

37



67.21.35

38



67.30.04
67.30.07
67.30.09

39

40



67.30.37

42



67.32.06

43

44

45



67.38.10
67.38.11
67.38.12

46



67.40.20

47



67.49.10

48



67.53.83

49



67.58.50

50



67.58.60

51



67.59.70

52



67.59.71

53



67.60.11

54



67.60.12

55



67.65.10

57



267.53.14

56



67.92.06

58



49.60.17

59



49.97.22



TREVALLi

**Rhinoplastiksieb
Rhinoplasty Set
Juego para rinoplastia
Boîte pour rhinoplastie
Set per rinoplastica**

Part 1

SR	Item number	Description	Quantity
01	01.22.10	Scalpel blade · fi gure 10 · sterile · packing unit 100 pieces	1
02	01.22.15	Scalpel blade · fi gure 15 · sterile · packing unit 100 pieces	1
03	01.27.07	Scalpel handle · no. 7 · long · 16,5 cm	1
04	01.30.32	Mini Scalpel handle · round · 13 cm	1
05	01.30.64	Mini Scalpel blade · fi gure 64 · sterile · packing unit 12 pieces	1
06	02.05.10	Scissor · curved · sharp · 10,5 cm	1
07	02.21.85	GRAEFE Iris scissors · angled · 10 cm	1
08	04.51.15	JOSEPH Scissors · curved · 15 cm	1
09	06.25.12	ADSON-BROWN Tissue forceps · straight · 7 × 7 teeth · 12 cm	1
10	09.21.74	Cotton carrier · Ø 1,2 mm · triangular serrated · 14 cm	3
11	09.83.08	FRAZIER Suction cannula · 8 French · angled · 12,5 cm	1
12	09.83.10	FRAZIER Suction cannula · 10 French · angled · 12,5 cm	1
13	09.84.58	YASARGIL Suction cannula · Ø 4,5 mm · 18 cm	1
14	10.08.12	NEIVERT Needle holder · smooth · 12,5 cm	1
15	10.39.17	SENNING Needle holder · 17 cm	1
16	26.42.25	MCKENTY Raspatory · 5 mm · 15 cm	1
17	33.04.18	COTTLE-KAZANJIAN Bone cutting forceps · straight · 18 cm	1
18	62.15.72	HARTMANN Ear hook · sharp · fi gure 2 · 16 cm	1
19	66.08.07	KILLIAN Nasal speculum · fi gure 3 - 75 mm · 14 cm	1
20	66.08.09	KILLIAN Nasal speculum · fi gure 4 - 90 mm · 14 cm	1
21	66.25.45	BLAKESLEY Nasal septum forceps · 12 cm	1
22	66.25.65	JANSEN-MIDDLETON Nasal septum rongeur · 19 cm	1
23	66.28.03	WEIL-BLAKESLEY Nasal forceps · straight · fi gure 3 - 4,2 mm	1
24	66.28.05	WEIL-BLAKESLEY Nasal forceps · straight · fi gure 5 - 5,6 mm	1
25	67.03.50	COTTLE Nasal septum speculum · 14 cm	1
26	67.10.20	COTTLE Septum knife · straight · 14 cm	1
27	67.15.48	JOSEPH-MASING Septum raspatory · 22 cm	1
28	67.15.93	Suction raspatory · with guide · Ø 4 mm · 20 cm	1
29	67.16.22	MASING Elevator · double-ended · 5 mm · 22 cm	1

Part 2 ▶



TREVALLi

Rhinoplastiksieb
Rhinoplasty Set
Juego para rinoplastia
Boîte pour rhinoplastie
Set per rinoplastica

Part 2

SR	Item number	Description	Quantity
30	67.16.65	COTTLE Elevator · double-ended · 4 mm · 22 cm	1
31	67.19.70	COTTLE Cartilage crusher	1
32	67.20.21	COTTLE Retractor · 2 teeth · ball tip/sharp · 10 mm · 14 cm	1
33	67.20.22	COTTLE Retractor · 2 teeth · sharp/ball tip · 10 mm · 14 cm	1
34	67.20.50	MASING Retractor · with guide · 17 mm · 20 cm	1
35	67.20.51	NEIVERT Retractor · with guide · 11 mm · 19 cm	1
36	67.21.15	COTTLE Alar retractor · 12 mm · 14 cm	1
37	67.21.35	AUFRICHT Nasal retractor · 45 × 9/7 mm · 18 cm	1
38	67.30.04	COTTLE Osteotome · graduated · 4 mm · 18 cm	1
39	67.30.07	COTTLE Osteotome · graduated · 7 mm · 18 cm	1
40	67.30.09	COTTLE Osteotome · graduated · 9 mm · 18 cm	1
41	67.30.37	COTTLE Cross bar chisel · 7 mm · 18 cm	1
42	67.32.06	COTTLE Chisel · curved · 6 mm · 18 cm	1
43	67.38.10	SILVER Nasal osteotome · straight · 18 cm	1
44	67.38.11	SILVER Nasal osteotome · curved right · 18 cm	1
45	67.38.12	SILVER Nasal osteotome · curved left · 18 cm	1
46	67.40.20	COTTLE Mallet · Ø 30 mm · 300 g · 19 cm	1
47	67.49.10	COTTLE-MASING Nasal scissors · curved · blunt · 10 cm	1
48	67.53.83	HOUGH Scissors · angled · 13 cm	1
49	67.58.50	COTTLE Nasal forceps · 15 cm	1
50	67.58.60	COTTLE Columella forceps · 11 cm	1
51	67.59.70	MASING Nasal file · fine · 21 cm	1
52	67.59.71	MASING Nasal file · coarse · 21 cm	1
53	67.60.11	JOSEPH Nasal saw · left · 18,5 cm	1
54	67.60.12	JOSEPH Nasal saw · right · 18,5 cm	1
55	67.65.10	WALSHAM UNIVERSAL Septum forceps · 23 cm	1
56	67.92.06	COTTLE-MASING Needle holder · 6 cm shaft	1
57	267.53.14	WALTER Nasal scissors · supercut · angled · 14 cm	1
58	49.60.17	Medlcontainer · 590 × 290 × 170 mm · silver	1
59	49.97.22	Wire basket · 510 × 255 × 70 mm	2



TREVALLI

Nasenseptumsieb
Nasal Septum Set
Juego para septum nasal
Boîte pour cloison nasale
Set per il setto nasale

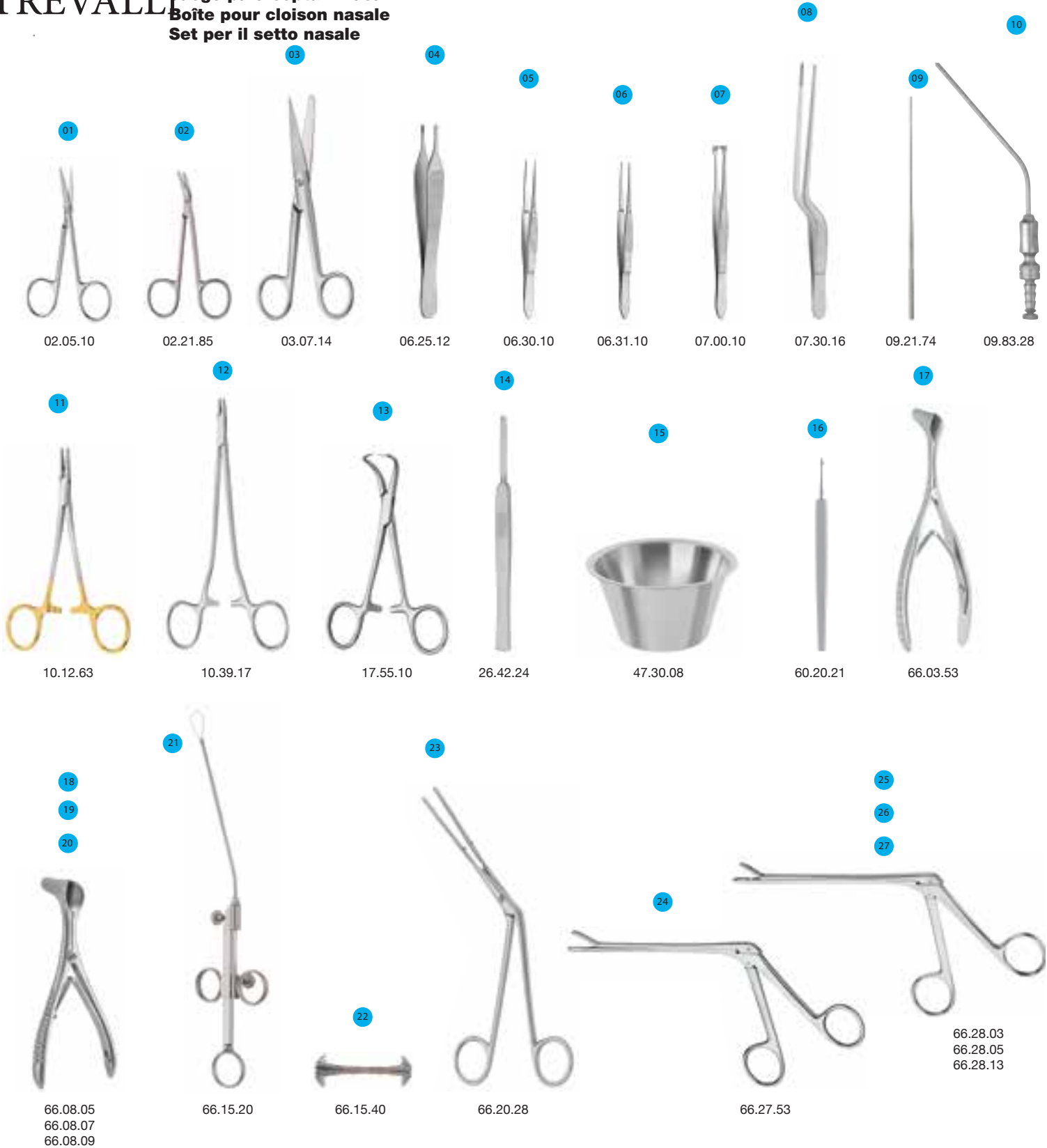



TREVALLi

**Nasenseptumsieb
Nasal Septum Set
Juego para septum nasal
Boîte pour cloison nasale
Set per il setto nasale**



66.40.20



66.52.20



67.03.50



67.10.20



67.15.80



67.15.93



67.16.22



67.16.65



67.21.15

37

38



67.30.04
67.30.07



67.40.20



67.49.10



67.58.50



67.58.60



72.00.50



88.00.20



88.00.40



88.17.25



204.51.15



267.53.14



49.60.13



49.97.21



TREVALLi

**Nasenseptumsieb
Nasal Septum Set
Juego para septum nasal
Boîte pour cloison nasale
Set per il setto nasale**

Part 1

SR	Item number	Description	Quantity
01	02.05.10	Scissors · curved · sharp · 10,5 cm	1
02	02.21.85	GRAEFE Iris scissors · angled · 10 cm	1
03	03.07.14	Operating scissors · curved · sharp/blunt · 14,5 cm	1
04	06.25.12	ADSON-BROWN Tissue forceps · straight · 7 x 7 teeth · 12 cm	1
05	06.30.10	Iris forceps · straight · serrated · 10 cm	1
06	06.31.10	Iris forceps · straight · 1 x 2 teeth · 10 cm	1
07	07.00.10	GRAEFE Fixation forceps · straight · 11 cm	1
08	07.30.16	GRUENWALD Bayonet forceps · serrated · 16 cm	1
09	09.21.74	Cotton carrier · Ø 1,2 mm · triangular serrated · 14 cm	2
10	09.83.28	FRAZIER (FERGUSSON) Suction cannula · 8 French · angled · 12,5 cm	1
11	10.12.63	HALSEY HM Needle holder · serrated · 13,5 cm	1
12	10.39.17	SENNING Needle holder · 17 cm	1
13	17.55.10	BACKHAUS Towel clamp · 10,5 cm	6
14	26.42.24	MCKENTY Raspatory · 4 mm · 15 cm	1
15	47.30.08	Round bowl · Ø 80 mm · height 35 mm · 0,1 l	2
16	60.20.21	WALTER Cataract needle · curved · 12 cm	1
17	66.03.53	HARTMANN-HALLE Nasal speculum · figure 3 · 15 cm	1
18	66.08.05	KILLIAN Nasal speculum · figure 2 - 50 mm · 14 cm	1
19	66.08.07	KILLIAN Nasal speculum · figure 3 - 75 mm · 14 cm	1
20	66.08.09	KILLIAN Nasal speculum · figure 4 - 90 mm · 14 cm	1
21	66.15.20	KRAUSE Nasal polypus snare · 26 cm	1
22	66.15.40	Snare wires · Ø 0,3 mm · packing unit 100 pieces	1
23	66.20.28	LUBET-BARBON Nasal dressing forceps · 20 cm	1
24	66.27.53	TAKAHASHI Nasal forceps · 3 x 10 mm · 12 cm	1
25	66.28.03	WEIL-BLAKESLEY Nasal forceps · straight · figure 3 - 4,2 mm · 12 cm	1
26	66.28.05	WEIL-BLAKESLEY Nasal forceps · straight · figure 5 - 5,6 mm · 12 cm	1
27	66.28.13	WEIL-BLAKESLEY Nasal forceps · 45° · figure 3 - 4,2 mm · 12 cm	1

Part 2 ▶



TREVALLi

Nasenseptumsieb
Nasal Septum Set
Juego para septum nasal
Boîte pour cloison nasale
Set per il setto nasale

Part 2

SR	Item number	Description	Quantity
28	66.40.20	HEYMANN Nasal scissors · 17 cm	1
29	66.52.20	Cartilage knife · curved · 13 cm	1
30	67.03.50	COTTLE Nasal septum speculum · 14 cm	1
31	67.10.20	COTTLE Septum knife · straight · 14 cm	1
32	67.15.80	Nasal fracture elevator · 17 cm	1
33	67.15.93	Suction raspatory · with guide · Ø 4 mm · 20 cm	1
34	67.16.22	MASING Elevator · double-ended · 5 mm · 22 cm	1
35	67.16.65	COTTLE Elevator · double-ended · 4 mm · 22 cm	1
36	67.21.15	COTTLE Alar retractor · 12 mm · 14 cm	1
37	67.30.04	COTTLE Osteotome · graduated · 4 mm · 18 cm	1
38	67.30.07	COTTLE Osteotome · graduated · 7 mm · 18 cm	1
39	67.40.20	COTTLE Mallet · Ø 30 mm · 300 g · 19 cm	1
40	67.49.10	COTTLE-MASING Nasal scissors · curved · blunt · 10 cm	1
41	67.58.50	COTTLE Nasal forceps · 15 cm	1
42	67.58.60	COTTLE Columella forceps · 11 cm	1
43	72.00.50	BRÜNING'S Tongue depressor · 14/18 mm · 19 cm	1
44	88.00.20	Bipolar connecting cable · Ø 12,5 mm · 3 m	1
45	88.00.40	Bracket · for high frequency cables · 22,5 cm	1
46	88.17.25	Coagulation forceps · bipolar · angled · sharp · 16,5 cm	1
47	204.51.15	JOSEPH Scissors · supercut · curved · 15 cm	1
48	267.53.14	WALTER Nasal scissors · supercut · angled · 14 cm	1
49	49.60.13	Mediccontainer · 590 × 290 × 135 mm · silver	1
50	49.97.21	Wire basket · 510 × 255 × 50 mm	2



TREVALLi

Endonasales Sieb
Endonasal Set
Juego endonasal
Boîte endonasale
Set endonasale

- 10
- 11
- 12
- 13
- 14

- 66.28.01
- 66.28.02
- 66.28.03
- 66.28.12
- 66.28.13

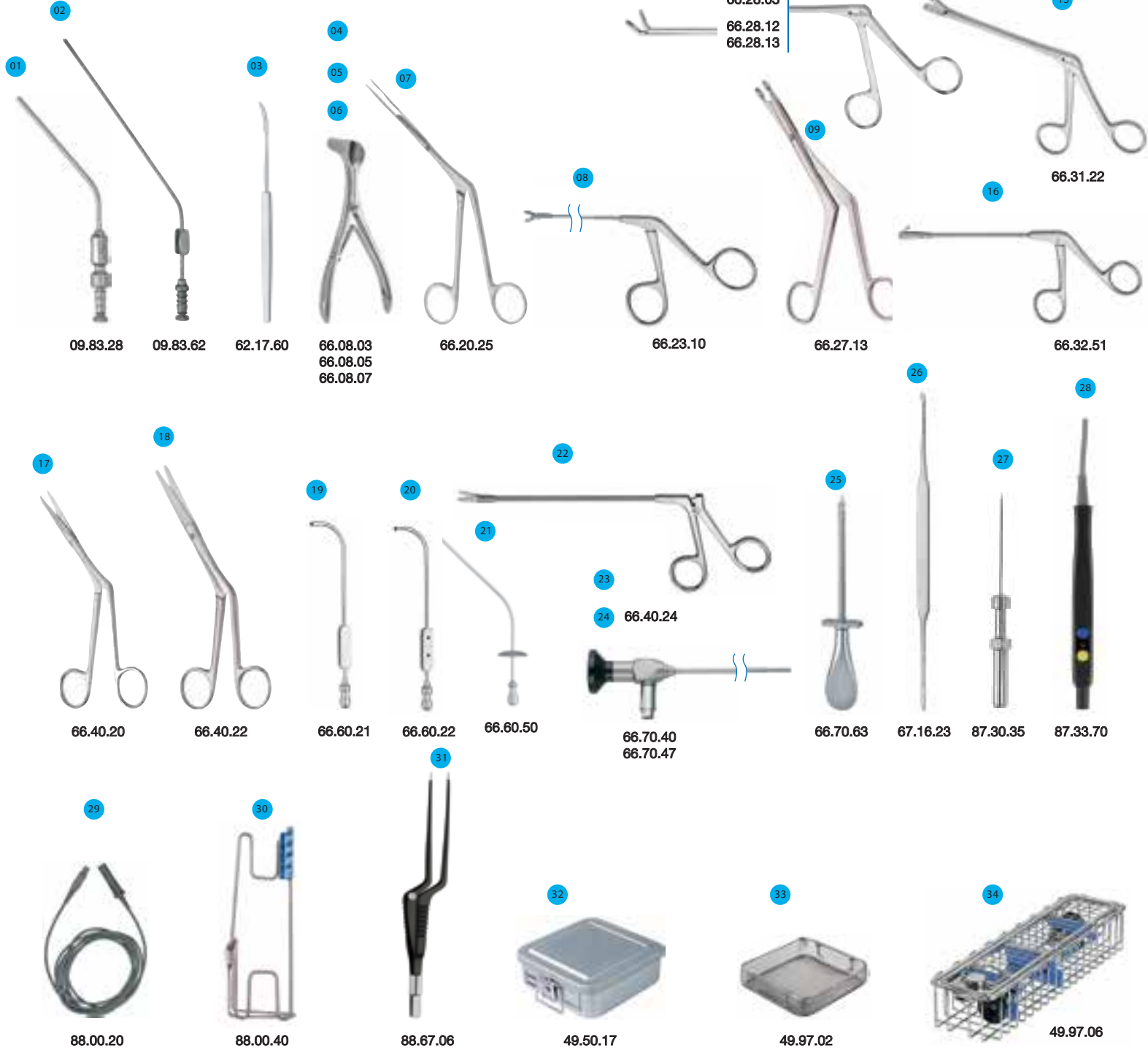



TREVALLi

**Endonasales Sieb
Endonasal Set
Juego endonasal
Boîte endonasale
Set endonasale**

SR	Item number	Description	Quantity
01	09.83.28	FRAZIER (FERGUSSON) Suction cannula · 8 French · angled · 12,5 cm	1
02	09.83.62	FRAZIER Suction cannula · 12 French · angled · 18 cm	1
03	62.17.60	POLITZER Sickle knife · 16 cm	1
04	66.08.03	KILLIAN Nasal speculum · fi gure 1 - 35 mm · 14 cm	1
05	66.08.05	KILLIAN Nasal speculum · fi gure 2 - 50 mm · 14 cm	1
06	66.08.07	KILLIAN Nasal speculum · fi gure 3 - 75 mm · 14 cm	1
07	66.20.25	WESTMACOTT Nasal dressing forceps · standard pattern · 20 cm	1
08	66.23.10	Biopsy forceps · cup jaws · 15 cm	1
09	66.27.13	LUC Nasal septum forceps · fi gure 3	1
10	66.28.01	WEIL-B LAKESLEY Nasal forceps · straight · fi gure 1 - 3,0 mm	1
11	66.28.02	WEIL-BLAKESLEY Nasal forceps · straight · fi gure 2 - 3,6 mm	1
12	66.28.03	WEIL-BLAKESLEY Nasal forceps · straight · fi gure 3 - 4,2 mm	1
13	66.28.12	WEIL-BLAKESLEY Nasal forceps · 45° · fi gure 2 - 3,6 mm	1
14	66.28.13	WEIL-BLAKESLEY Nasal forceps · 45° · fi gure 3 - 4,2 mm	1
15	66.31.22	HAJEK-GRUENWALD Nasal forceps · fi gure 2 · 12 cm	1
16	66.32.51	Nasal punch · 2,5 mm · backwards cutting · 10 cm	1
17	66.40.20	HEYMANN Nasal scissors · 17 cm	1
18	66.40.22	HEYMANN Nasal scissors · 20 cm	1
19	66.40.24	Nasal scissors · straight · 13,5 cm	1
20	66.60.21	KILLIAN Antrum cannula · 3,0 mm · 15 cm	1
21	66.60.22	KILLIAN Antrum cannula · 3,5 mm · 15 cm	1
22	66.60.50	Suction and irrigation tube · Ø 2 mm · 11 cm	1
23	66.70.40	Sinuscope · Ø 4 mm · 0° · 175 mm	1
24	66.70.47	Sinuscope · Ø 4 mm · 70° · 175 mm	1
25	66.70.63	Trocar · breaked point · Ø 2,7 mm	1
26	67.16.23	COTTLE Elevator · double-ended · 4/3 mm · 23 cm	1
27	87.30.35	Needle electrode · 0,5 × 25 mm	1
28	87.33.70	Electrode handle · Ø 4 mm · with cable 4,5 m	1
29	88.00.20	Bipolar cable · Ø 12,5 mm · 3m	1
30	88.00.40	Bracket · for high frequency cables · 22,5 cm	1
31	88.67.06	Coagulation forceps · bipolar · bayonet · blunt · 16,5 cm	1
32	49.50.17	Medicontainer · 290 × 290 × 170 mm · silver	1
33	49.97.02	Wire basket · 240 × 255 × 50 mm	2
34	49.97.06	Endoscope wire basket · 290 × 80 × 52 mm · for 2 endoscopes	1



TREVALLi

Kleines Kieferhöhlensieb
Small Set for Maxillary Sinus
Juego pequeño para el seno maxilar
Boîte petite pour le sinus maxillaire
Set piccolo per sinus maxillar

01 02 03 04 05 06 07 08 09 10 11 12

01.22.10 01.27.07 03.03.13 06.00.14 06.05.14 07.35.13 17.21.56 26.29.07 27.02.10 27.57.04 27.57.06

13 14 15 16 17 18 19 20 21 22 23 24 25 26 27

29.13.01 29.13.02 29.13.03 47.32.14 66.08.03 66.08.05 66.08.07 66.08.09 66.15.20 66.31.21 66.31.22 66.28.02 66.28.03 66.60.10 66.60.22

28 29 30 31 32 33 34 35

66.60.82 66.60.83 66.60.84 67.02.55 72.00.15 204.33.14 49.50.15 49.97.02



TREVALLi

Kleines Kieferhöhlensieb
Small Set for Maxillary Sinus
Juego pequeño para el seno maxilar
Boîte petite pour le sinus maxillaire
Set piccolo per sinus maxillar

SR	Item number	Description	Quantity
01	01.22.10	Scalpel blade · fi gure 10 · sterile · packing unit 100 pieces	1
02	01.27.07	Scalpel handle · no. 7 · long · 16,5 cm	1
03	03.03.13	Operating scissors · curved · blunt/blunt · 13 cm	1
04	06.00.14	Dressing forceps · standard · 14,5 cm	1
05	06.05.14	Tissue forceps · 1 x 2 teeth · standard · 14,5 cm	1
06	07.35.13	TROELTSCH (WILDE) Ear forceps · 13 cm	1
07	17.21.56	SCHNIDT (SAWTELL) Forceps · strongly curved · 19 cm	1
08	17.55.10	BACKHAUS Towel clamp · 10,5 cm	2
09	26.29.07	LANGENBECK Elevator · 7 mm · 20 cm	1
10	27.02.10	Metal mallet · solid head · Ø 20 mm · 100 g · 16,5 cm	1
11	27.57.04	MINI-LAMBOTTE Osteotome · 4 mm · 13 cm	1
12	27.57.06	MINI-LAMBOTTE Osteotome · 6 mm · 13 cm	1
13	29.13.01	Sharp curette · straight · 15 cm	1
14	29.13.02	Sharp curette · curved right · 15 cm	1
15	29.13.03	Sharp curette · curved left · 15 cm	1
16	47.32.14	Round bowl · Ø 140 mm · height 35 mm · 0,35 l	1
17	66.08.03	KILLIAN Nasal speculum · fi gure 1 - 35 mm · 14 cm	1
18	66.08.05	KILLIAN Nasal speculum · fi gure 2 - 50 mm · 14 cm	1
19	66.08.07	KILLIAN Nasal speculum · fi gure 3 - 75 mm · 14 cm	1
20	66.08.09	KILLIAN Nasal speculum · fi gure 4 - 90 mm · 14 cm	1
21	66.15.20	KRAUSE Nasal polypus snare · 26 cm	1
22	66.28.02	WEIL-BLAKESLEY Nasal forceps · straight · fi gure 2 - 3,6 mm · 12 cm	1
23	66.28.03	WEIL-BLAKESLEY Nasal forceps · straight · fi gure 3 - 4,2 mm · 12 cm	1
24	66.31.21	HAJEK-GRUENWALD Nasal forceps · fi gure 1 · 12 cm	1
25	66.31.22	HAJEK-GRUENWALD Nasal forceps · fi gure 2 · 12 cm	1
26	66.60.10	EICKEN Wash cannula · Ø 3 mm · Record · 15 cm	1
27	66.60.22	KILLIAN Antrum cannula · 3,5 mm · 15 cm	1
28	66.60.82	RITTER-HALLE Sinus dilator · Ø 2,5 mm · 16 cm	1
29	66.60.83	RITTER-HALLE Sinus dilator · Ø 3,0 mm · 16 cm	1
30	66.60.84	RITTER-HALLE Sinus dilator · Ø 4,0 mm · 16 cm	1
31	67.02.55	COTTLE Nasal speculum · fi gure 2 - 55 mm · 14 cm	1
32	72.00.15	Tongue depressor · 20/23 mm · 14 cm	1
33	204.33.14	METZENBAUM Scissors · supercut · curved · 14 cm	1
34	49.50.15	Mediccontainer · 290 x 290 x 150 mm · silver	1
35	49.97.02	Wire basket · 240 x 255 x 50 mm	1



TREVALLI

Sieb zur sinuskopischen Nasennebenhöhlen-Chirurgie
Set for Sinusocpical Paranasal Sinuses Surgery
Juego para cirugía sinusocpica del seno paranasal
Boîte sinusocpie du sinus nasal
Set chirurgia sinusocpia per il seno paranasale

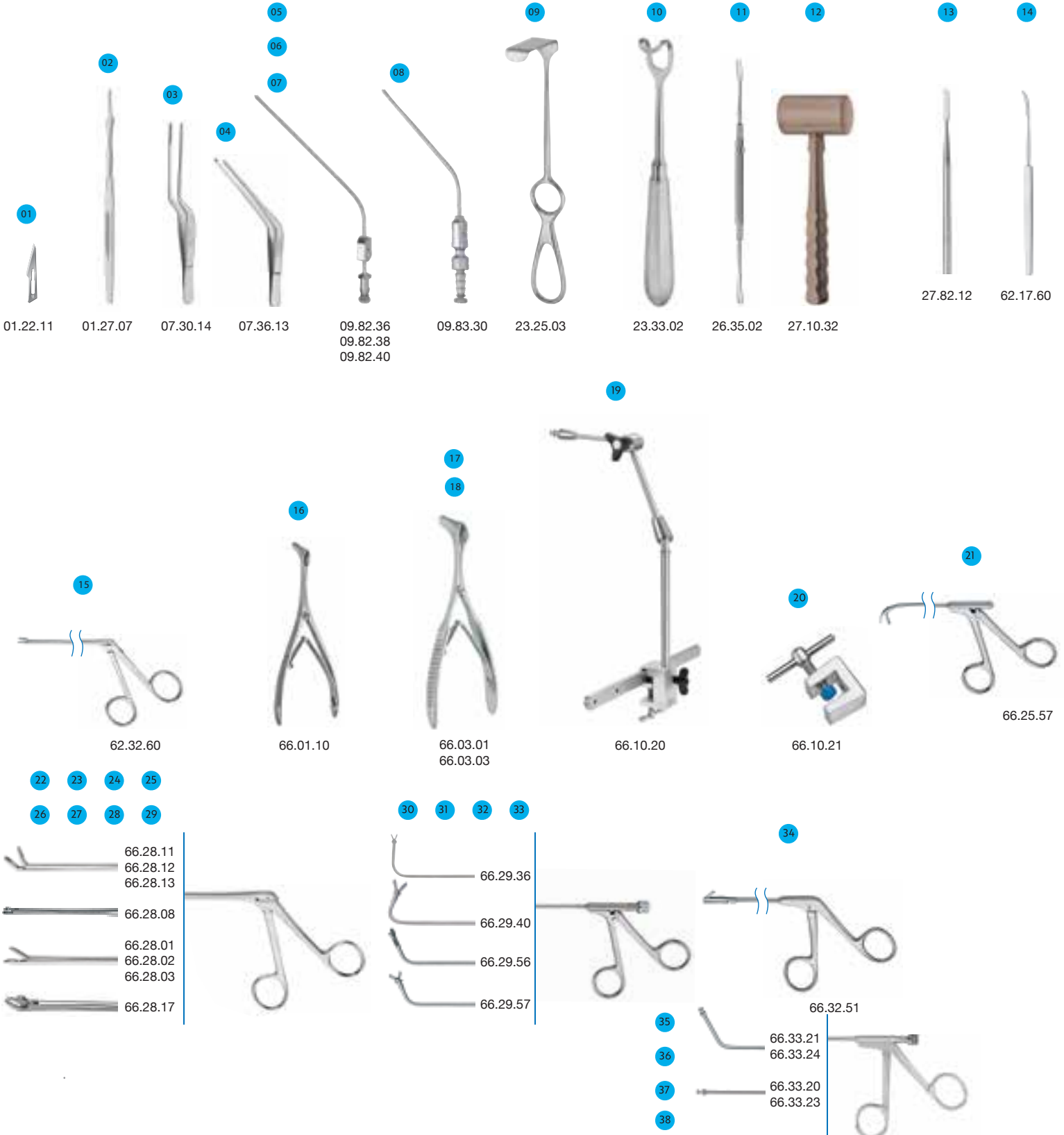



TREVALLi

Sieb zur sinuskopischen Nasennebenhöhlen-Chirurgie
Set for Sinusocpical Paranasal Sinuses Surgery
Juego para cirugía sinusocpica del seno paranasal
Boîte sinusocpie du sinus nasal
Set chirurgia sinusocpia per il seno paranasale

39
40



66.58.92
66.58.94

41
42



66.60.21
66.60.22

43



66.60.82

44
45



66.70.05
66.70.07

46
47



66.70.43
66.70.47

48
49



66.70.63
66.70.65

50
51



67.05.55
67.06.55

52



88.00.20

53



88.00.40

54



88.70.05

55



88.90.20

56



266.40.21

57



49.60.22

58

59



49.97.21
49.97.22



Sieb zur sinuskopischen Nasennebenhöhlen-Chirurgie
Set for Sinusopical Paranasal Sinuses Surgery
Juego para cirugía sinusopica del seno paranasal
Boîte sinuscopie du sinus nasal
Set chirurgia sinoscopia per il seno paranasale

Part 1

SR	Item number	Description	Quantity
01	01.22.11	Scalpel blade · fi gure 11 · sterile · packing unit 100 pieces	1
02	01.27.07	Scalpel handle · no. 7 · long · 16,5 cm	1
03	07.30.14	LUCAE Bayonet forceps · serrated · 14 cm	1
04	07.36.13	TROELTSCH (WILDE) Forceps · angled · 1 x 2 teeth · 13 cm	1
05	09.82.36	FRAZIER Suction tube · graduated 5 - 9 cm · 6 French · 10 cm	1
06	09.82.38	FRAZIER Suction tube · graduated 5 - 9 cm · 8 French · 10 cm	1
07	09.82.40	FRAZIER Suction tube · graduated 5 - 9 cm · 10 French · 10 cm	1
08	09.83.30	FRAZIER (FERGUSSON) Suction cannula · 10 French · angled · 12,5 cm	1
09	23.25.03	LANGENBECK-KOCHER Retractor · 10 x 30 mm · 21 cm	1
10	23.33.02	MIDDELDORPF Retractor · 22 x 22 mm · 20,5 cm	1
11	26.35.02	FREER Elevator · double-ended · sharp/blunt · 5 mm · 19 cm	1
12	27.10.32	Mallet · 240 g · Ø 45 mm · 26 cm	1
13	27.82.12	WEST Osteotome · straight · 4 mm · 16 cm	1
14	62.17.60	POLITZER Sickle knife · 16 cm	1
15	62.32.60	STRÜMPEL Ear forceps · 2,5 x 5 mm · 8 cm	1
16	66.01.10	TIECK-HALLE Nasal speculum · for babies · 13,5 cm	1
17	66.03.01	HARTMANN-HALLE Nasal speculum · fi gure 1 · 15 cm	1
18	66.03.03	HARTMANN-HALLE Nasal speculum · fi gure 3 · 15 cm	1
19	66.10.20	Holding arm variable · with universal clamp base	1
20	66.10.21	Universal holder · for instruments and optics	1
21	66.25.57	Antrum grasping forceps · shaft curved · 13 cm	1
22	66.28.01	WEIL-BLAKESLEY Nasal forceps · straight · fi gure 1 - 3,0 mm · 12 cm	1
23	66.28.02	WEIL-BLAKESLEY Nasal forceps · straight · fi gure 2 - 3,6 mm · 12 cm	1
24	66.28.03	WEIL-BLAKESLEY Nasal forceps · straight · fi gure 3 - 4,2 mm · 12 cm	1
25	66.28.08	WEIL-BLAKESLEY Nasal forceps · through-cutting · straight · 3,0 mm · 11,5 cm	1
26	66.28.11	WEIL-BLAKESLEY Nasal forceps · 45° · fi gure 1 - 3,0 mm · 12 cm	1
27	66.28.12	WEIL-BLAKESLEY Nasal forceps · 45° · fi gure 2 - 3,6 mm · 12 cm	1
28	66.28.13	WEIL-BLAKESLEY Nasal forceps · 45° · fi gure 3 - 4,2 mm · 12 cm	1
29	66.28.17	WEIL-BLAKESLEY Nasal forceps · through-cutting · 45° · 3,0 mm · 11,5 cm	1
30	66.29.36	Nasal forceps · angled upwards 90° · vertical opening · Ø 2,7 mm · 13 cm	1
31	66.29.40	Nasal forceps · angled upwards 110° · vertical opening · Ø 2,7 mm · 13 cm	1
32	66.29.56	Nasal forceps · angled upwards 70° · horizontal opening · Ø 2,7 mm · 13 cm	1
33	66.29.57	Nasal forceps · angled upwards 70° · vertical opening · Ø 2,7 mm · 13 cm	1
34	66.32.51	Antrum punch · upwards cutting backwards · 2,5 mm · 10 cm	1
35	66.33.20	Punch circular cutting · straight · Ø 3,5 mm · 16 cm	1
36	66.33.21	Punch circular cutting · angled upwards 60° · Ø 3,5 mm · 16 cm	1
37	66.33.23	Punch circular cutting · straight · Ø 4,5 mm · 16 cm	1
38	66.33.24	Punch circular cutting · angled upwards 60° · Ø 4,5 mm · 16 cm	1

Part 2 ▶



TREVALLi

Sieb zur sinuskopischen Nasennebenhöhlen-Chirurgie
Set for Sinuscopical Paranasal Sinuses Surgery
Juego para cirugía sinusopica del seno paranasal
Boîte sinuscopie du sinus nasal
Set chirurgia sinusocopia per il seno paranasale

Part 2

SR	Item number	Description	Quantity
39	66.58.92	Frontal sinus curette · 3,5 × 5 mm · 55° curved downwards · 19 cm	1
40	66.58.94	Frontal sinus curette · 3,5 × 5 mm · 90° curved downwards · 19 cm	1
41	66.60.21	KILLIAN Irrigating tube · Luer · 3,0 mm · 15 cm	1
42	66.60.22	KILLIAN Irrigating tube · Luer · 3,5 mm · 15 cm	1
43	66.60.82	RITTER-HALLE Frontal sinus dilator · S-curved · Ø 2,5 mm · 16 cm	1
44	66.70.05	Suction-/Irrigating system 0°/30° for optic Ø 4,0 mm · 175 mm	1
45	66.70.07	Suction-/Irrigating system 70° for optic Ø 4,0 mm · 175 mm	1
46	66.70.43	Sinuscope · Ø 4 mm · 30° · 175 mm	1
47	66.70.47	Sinuscope · Ø 4 mm · 70° · 175 mm	1
48	66.70.63	Sinuscopy trocar · beaked point · Ø 2,7 mm	1
49	66.70.65	Sinuscopy trocar · beaked point · Ø 4,0 mm	1
50	67.05.55	Nasal speculum · for exible tension arm · left 55 mm · right 35 mm with teeth	1
51	67.06.55	Nasal speculum · for exible tension arm · right 55 mm · left 35 mm with teeth	1
52	88.00.20	Bipolar connecting cable · Ø 12,5 mm · 3 m	1
53	88.00.40	Bracket · for high fre uenc cables	1
54	88.70.05	Coagulation forceps · bipolar · 19 cm · sharp	1
55	88.90.20	B NNER Nasal concha coagulation electrode · 18,5 cm	1
56	266.40.21	HEYMANN Nasal scissors · supercut · 18 cm	1
57	49.60.22	Medicontainer · 590 × 290 × 220 mm · silver	1
58	49.97.21	Wire basket · 510 × 255 × 50 mm	1
59	49.97.22	Wire basket · 510 × 255 × 70 mm	2



TREVALLi

Sieb zur Mikroskop gestützten endoskopischen Nasennebenhöhlen-Chirurgie
Set for Microscopically Assisted Endoscopic Paranasal Sinuses Surgery
Juego para cirugía endoscópica del seno paranasal asistida microscópicamente
Boîte chirurgie microscopique - endoscopique pour sinus nasal
Set chirurgia endoscópica del seno paranasale assistita dal microscopio

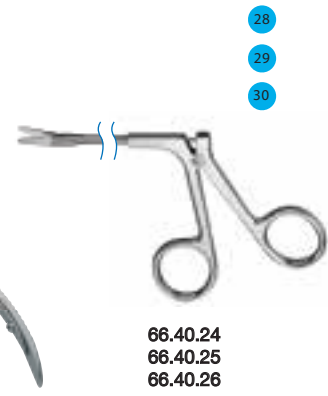
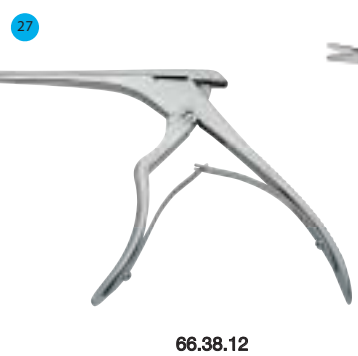
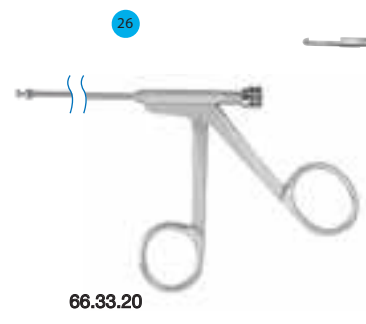
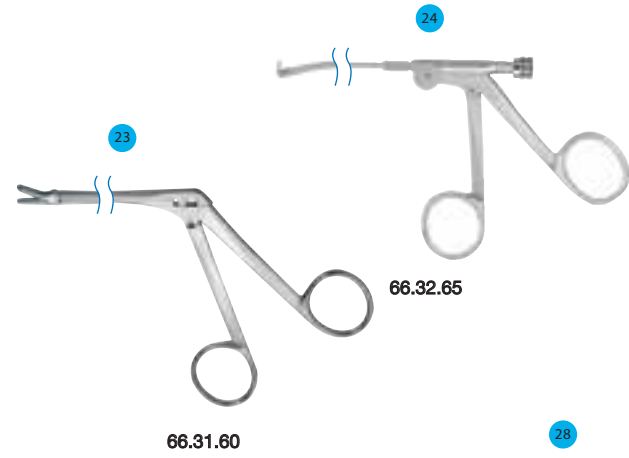
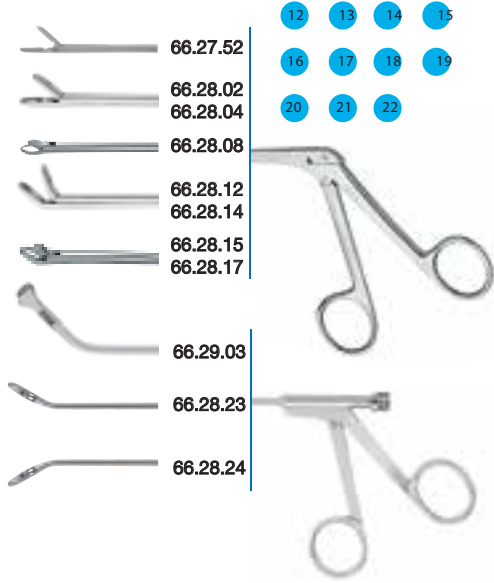
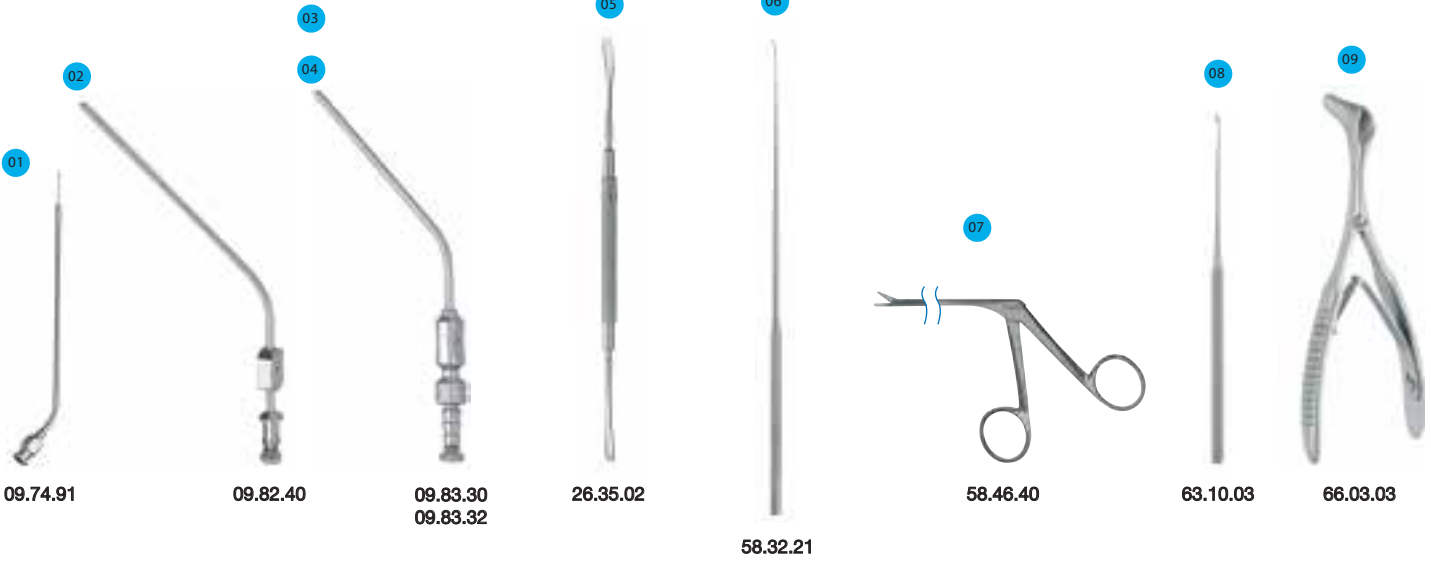



TREVALLi

Sieb zur Mikroskop gestützten endoskopischen Nasennebenhöhlen-Chirurgie
Set for Microscopically Assisted Endoscopic Paranasal Sinuses Surgery
Juego para cirugía endoscópica del seno paranasal asistida microscópicamente
Boîte à chirurgie microscopique - endoscopique pour sinus nasal
Set chirurgia endoscópica del seno paranasal asistida dal microscopio

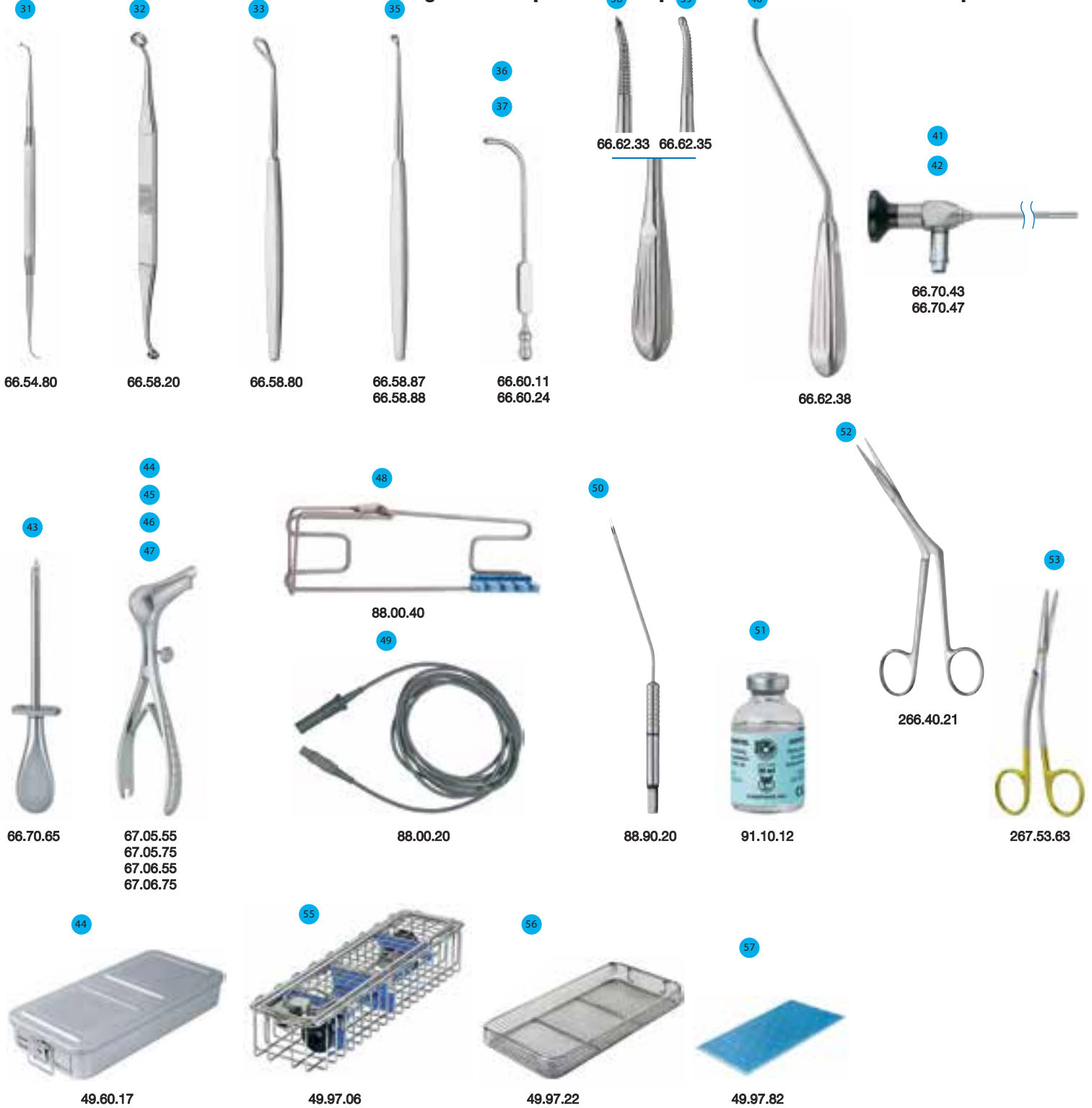



TREVALLI

Sieb zur Mikroskop gestützten endoskopischen Nasennebenhöhlen-Chirurgie
Set for Microscopically Assisted Endoscopic Paranasal Sinuses Surgery
Juego para cirugía endoscópica del seno paranasal asistida microscópicamente
Boîte chirurgie microscopique - endoscopique pour sinus nasal
Set chirurgia endoscopica del seno paranasale assistita dal microscopio

Part 1

SR	Item number	Description	Quantity
01	09.74.91	Septum needle · angled · Ø 0,8 mm · Luer-Lock	1
02	09.82.40	FRAZIER Suction tube · graduated 5 - 9 cm · 10 French · 10 cm	1
03	09.83.30	FRAZIER (FERGUSSON) Suction cannula · 10 French · 12,5 cm	1
04	09.83.32	FRAZIER (FERGUSSON) Suction cannula · 12 French · 12,5 cm	1
05	26.35.02	FREER Elevator · double-ended · sharp/blunt · 5 mm · 19 cm	1
06	58.32.21	Micro dissector · curved · 1 mm · 23 cm	1
07	58.46.40	Micro scissors · very delicate · straight · blunt · 14 cm	1
08	63.10.03	GUILFORD-WRIGHT Flap knife · 2 mm · 15 cm	1
09	66.03.03	HARTMANN-HALLE Nasal speculum · figure 3 · 15 cm	1
10	66.10.20	Holding arm variable · with universal clamp base	1
11	66.10.21	Universal holder · for instruments and optics	1
12	66.27.52	TAKAHASHI Ethmoid bone forceps · 2 × 10 mm · 12 cm	1
13	66.28.02	WEIL-BLAKESLEY Nasal forceps · straight · figure 2 - 3,6 mm · 12 cm	1
14	66.28.04	WEIL-BLAKESLEY Nasal forceps · straight · figure 4 - 4,8 mm · 12 cm	1
15	66.28.08	WEIL-BLAKESLEY Nasal forceps · through-cutting · straight · 3,0 mm · 11,5 cm	1
16	66.28.12	WEIL-BLAKESLEY Nasal forceps · angled upwards 45° · figure 2 - 3,6 mm · 12 cm	1
17	66.28.14	WEIL-BLAKESLEY Nasal forceps · angled upwards 45° · figure 4 - 4,8 mm · 12 cm	1
18	66.28.15	WEIL-BLAKESLEY Nasal forceps · through-cutting · angled upw. 45° · 2,0 mm · 11,5 cm	1
19	66.28.17	WEIL-BLAKESLEY Nasal forceps · through-cutting · angled upw. 45° · 3,0 mm · 11,5 cm	1
20	66.28.23	WEIL-BLAKESLEY Nasal forceps · through-cutting · 30° · curved right · 2,5 mm · 11,5 cm	1
21	66.28.24	WEIL-BLAKESLEY Nasal forceps · through-cutting · 30° · curved left · 2,5 mm · 11,5 cm	1
22	66.29.03	Polyp grasping forceps · Ø 2,7 mm · angled upwards 45° · 13 cm	1
23	66.31.60	GRUENWALD Nasal forceps · through-cutting · 2,5 × 11,5 mm · 14 cm	1
24	66.32.65	OSTRUM Rongeur · shaft curved · backwards cutting · 360° rotatable · 2,0 mm · 10 cm	1
25	66.32.74	OSTRUM Rongeur · with suction · upwards cutting backwards · 2,5 mm · 10 cm	1
26	66.33.20	Punch circular cutting · Ø 3,5 mm · straight · 16 cm	1
27	66.38.12	Antrum rongeur · with hook jaw · through-cutting · 3 mm · 15 cm	1
28	66.40.24	Nasal scissors · lower cutting edge toothed · straight · 13,5 cm	1
29	66.40.25	Nasal scissors · lower cutting edge toothed · curved right · 13,5 cm	1
30	66.40.26	Nasal scissors · lower cutting edge toothed · curved left · 13,5 cm	1

Part 2 ▶



TREVALLI

Sieb zur Mikroskop gestützten endoskopischen Nasennebenhöhlen-Chirurgie
Set for Microscopically Assisted Endoscopic Paranasal Sinuses Surgery
Juego para cirugía endoscópica del seno paranasal asistida microscópicamente
Boîte chirurgie microscopique – endoscopique pour sinus nasal
Set chirurgia endoscópica del seno paranasale assistita dal microscopio

Part 2

SR	Item number	Description	Quantity
31	66.54.80	Double probe · ball end · Ø 1,2 mm / 2,0 mm · 19 cm	1
32	66.58.20	FAULKNER Antrum curette · double-ended · 21,5 cm	1
33	66.58.80	Antrum curette · small · oval · 19 cm	1
34	66.58.87	Antrum curette · round · 5 mm · 20 cm	1
35	66.58.88	Antrum curette · oval · 3,0 × 6,0 mm · 20 cm	1
36	66.60.11	EICKEN Irrigating tube · Ø 3 mm · Luer · 15 cm	1
37	66.60.24	KILLIAN Irrigating tube · Luer · 3,5 mm · 15 cm	1
38	66.62.33	WIENER Antrum rasp · with trocar tip · Ø 3,5 mm · 18 cm	1
39	66.62.35	WIENER Antrum rasp · with blunt tip · Ø 3,5 mm · 18 cm	1
40	66.62.38	WATSON-WILLIAMS Frontal sinus rasp · blunt · 23 cm	1
41	66.70.43	Sinuscope · Ø 4 mm · 30° · 175 mm	1
42	66.70.47	Sinuscope · Ø 4 mm · 70° · 175 mm	1
43	66.70.65	Sinuscopy trocar · beaked point · Ø 4,0 mm	1
44	67.05.55	Nasal speculum · for fl exible tension arm · left 55 mm · right 35 mm · 15 cm	1
45	67.05.75	Nasal speculum · for fl exible tension arm · right 55 mm · left 35 mm · 15 cm	1
46	67.06.55	Nasal speculum · for fl exible tension arm · left 75 mm · right 35 mm · 15 cm	1
47	67.06.75	Nasal speculum · for fl exible tension arm · right 75 mm · left 35 mm · 15 cm	1
48	88.00.20	Bipolar connecting cable · Ø 12,5 mm · 3 m	1
49	88.00.40	Bracket · for high frequency cables · 22,5 cm	1
50	88.90.20	BINNER Nasal concha coagulation electrode · 18,5 cm	1
51	91.10.12	Antifog solution · bottle · sterile · 30 ml	1
52	266.40.21	HEYMANN Nasal scissors · supercut · 18 cm	1
53	267.53.63	PLUS FOMON Nasal scissors · supercut plus · 13 cm	1
54	49.60.17	Medicontainer · 590 × 290 × 170 mm · silver	1
55	49.97.06	Endoscope wire basket · 290 × 80 × 52 mm · for 2 endoscopes	1
56	49.97.22	Wire basket · 510 × 255 × 70 mm	2
57	49.97.82	Silicone mat · 13 mm · 467 × 240 mm	1



TREVALLI

Sieb zur funktionellen endoskopischen Nasennebenhöhlen-Chirurgie
Set for Functional Endoscopic Paranasal Sinuses Surgery
Juego para cirugía endoscopica funcional del seno paranasal
Boîte chirurgie fonctionelle endoscopique du sinus nasal
Set chirurgia funzionale del seno paranasale endoscopica

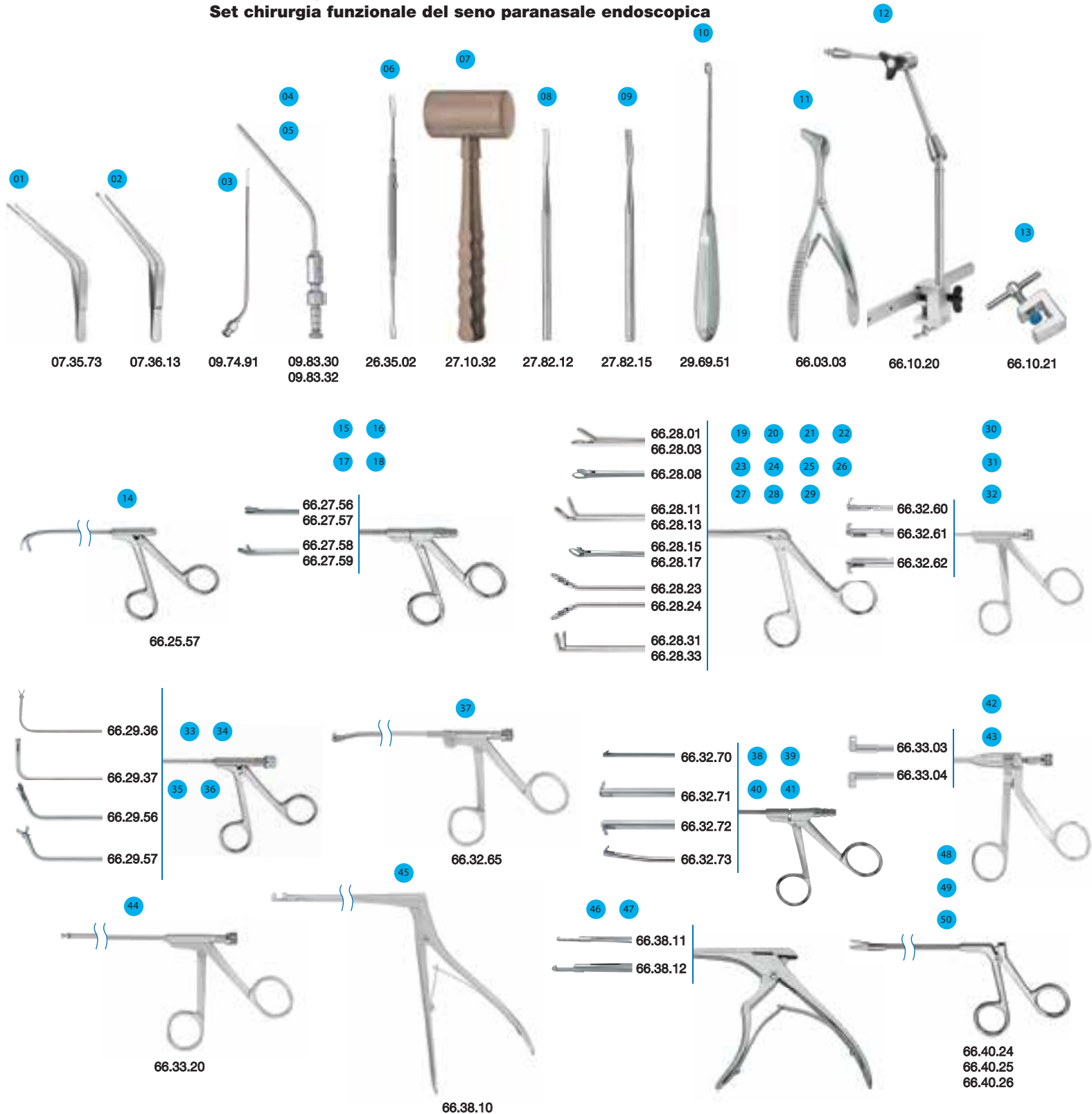



TREVALLi

Sieb zur funktionellen endoskopischen Nasennebenhöhlen-Chirurgie
Set for Functional Endoscopic Paranasal Sinuses Surgery
Juego para cirugía endoscópica funcional del seno paranasal
Boîte chirurgie fonctionnelle endoscopique du sinus nasal
Set chirurgia funzionale del seno paranasale endoscopica

51

52

53

54

55

56

57

58

59

60

61

62

63

64



66.52.80
66.52.81



66.54.80



66.58.20



66.58.80



66.58.87
66.58.88



66.60.11



66.60.24



66.70.27
66.70.40
66.70.43



66.70.65



67.16.23

65



68.82.32

66



88.00.20

67



88.00.40

68



88.20.26

69



91.10.12

70



266.40.21

71



267.53.63

72



49.60.17

73



49.97.06

74



49.97.21

75



49.97.82



Sieb zur funktionellen endoskopischen Nasennebenhöhlen-Chirurgie
Set for Functional Endoscopic Paranasal Sinuses Surgery
Juego para cirugía endoscópica funcional del seno paranasal
Boîte chirurgie fonctionnelle endoscopique du sinus nasal
Set chirurgia funzionale del seno paranasale endoscopica

Part 1

SR	Item number	Description	Quantity
01	07.35.73	TROELTSCH Forceps · angled · serrated · 13 cm	1
02	07.36.13	TROELTSCH (WILDE) Forceps · angled · 1 × 2 teeth · 13 cm	1
03	09.74.91	Septum needle · angular · Ø 0,8 mm · Luer-Lock	1
04	09.83.30	FRAZIER (FERGUSSON) Suction cannula · 10 French · 12,5 cm	1
05	09.83.32	FRAZIER (FERGUSSON) Suction cannula · 12 French · 12,5 cm	1
06	26.35.02	FREER Elevator · double-ended · sharp/blunt · 5 mm · 19 cm	1
07	27.10.32	Mallet · 240 g · Ø 45 mm · 26 cm	1
08	27.82.12	WEST Osteotome · straight · 4 mm · 16 cm	1
09	27.82.15	WEST Chisel · curved · 4 mm · 16 cm	1
10	29.69.51	HALLE Sharp curette · malleable · oval · figure 1 · 4 mm · 21 cm	1
11	66.03.03	HARTMANN-HALLE Nasal speculum · figure 3 · 15 cm	1
12	66.10.20	Holding arm variable · with universal clamp base	1
13	66.10.21	Universal holder · for instruments and optics	1
14	66.25.57	Antrum grasping forceps · shaft curved · 13 cm	1
15	66.27.56	TAKAHASHI Nasal forceps · Ø 4,0 mm · straight · 2,5 mm · 10 cm	1
16	66.27.57	TAKAHASHI Nasal forceps · Ø 4,0 mm · straight · 3,5 mm · 10 cm	1
17	66.27.58	TAKAHASHI Nasal forceps · Ø 4,0 mm · angled upwards 45° · 2,5 mm · 10 cm	1
18	66.27.59	TAKAHASHI Nasal forceps · Ø 4,0 mm · angled upwards 45° · 3,5 mm · 10 cm	1
19	66.28.01	WEIL-BLAKESLEY Nasal forceps · straight · figure 1 · 3,0 mm · 12 cm	1
20	66.28.03	WEIL-BLAKESLEY Nasal forceps · straight · figure 3 · 4,2 mm · 12 cm	1
21	66.28.08	WEIL-BLAKESLEY Nasal forceps · through-cutting · straight · 3,0 mm · 11,5 cm	1
22	66.28.11	WEIL-BLAKESLEY Nasal forceps · angled upwards 45° · figure 1 · 3,0 mm · 12 cm	1
23	66.28.13	WEIL-BLAKESLEY Nasal forceps · angled upwards 45° · figure 3 · 4,2 mm · 12 cm	1
24	66.28.15	WEIL-BLAKESLEY Nasal forceps · through-cutting · 45° · 2,0 mm · 11,5 cm	1
25	66.28.17	WEIL-BLAKESLEY Nasal forceps · through-cutting · 45° · 3,0 mm · 11,5 cm	1
26	66.28.23	WEIL-BLAKESLEY Nasal forceps · through-cutting · 30° · curved right · 2,5 mm · 11,5 cm	1
27	66.28.24	WEIL-BLAKESLEY Nasal forceps · through-cutting · 30° · curved left · 2,5 mm · 11,5 cm	1
28	66.28.31	WEIL-BLAKESLEY Nasal forceps · angled upwards 90° · figure 1 · 3,0 mm · 12 cm	1
29	66.28.33	WEIL-BLAKESLEY Nasal forceps · angled upwards 90° · figure 3 · 4,2 mm · 12 cm	1
30	66.29.36	Nasal forceps · angled upwards 90° · vertical opening · Ø 2,7 mm · 13 cm	1
31	66.29.37	Nasal forceps · angled upwards 90° · horizontal opening · Ø 2,7 mm · 13 cm	1
32	66.29.56	Nasal forceps · angled upwards 70° · horizontal opening · Ø 2,7 mm · 13 cm	1
33	66.29.57	Nasal forceps · angled upwards 70° · vertical opening · Ø 2,7 mm · 13 cm	1
34	66.32.60	OSTRUM Rongeur · straight · upwards cutting backwards · 2,5 mm · 10 cm	1
35	66.32.61	OSTRUM Rongeur · straight · right cutting backwards · 2,5 mm · 10 cm	1
36	66.32.62	OSTRUM Rongeur · straight · left cutting backwards · 2,5 mm · 10 cm	1
37	66.32.65	OSTRUM Rongeur · shaft curved · backwards cutting · 360° rotatable · 2,0 mm · 10 cm	1
38	66.32.70	OSTRUM Rongeur · with suction · upwards cutting backwards · 2,0 mm · 10 cm	1
39	66.32.71	OSTRUM Rongeur · with suction · right cutting backwards · 2,0 mm · 10 cm	1
40	66.32.72	OSTRUM Rongeur · with suction · left cutting backwards · 2,0 mm · 10 cm	1
41	66.32.73	OSTRUM Rongeur · shaft curved · upwards cutting backwards · Ø 2,0 mm, 10 cm	1
42	66.33.03	Antrum punch · large jaw · through-cutting right · 3,5 mm · 10 cm	1
43	66.33.04	Antrum punch · large jaw · through-cutting left · 3,5 mm · 10 cm	1
44	66.33.20	Punch · circular cutting · Ø 3,5 mm · straight · 16 cm	1
45	66.38.10	HAJEK-KOFLER Rongeur · 3 × 5 mm · 360° rotatable · 16 cm	1
46	66.38.11	Antrum rongeur · with hook jaw · through-cutting · 2 mm · 18 cm	1
47	66.38.12	Antrum rongeur · with hook jaw · through-cutting · 3 mm · 15 cm	1
48	66.40.24	Nasal scissors · lower cutting edge toothed · straight · 13,5 cm	1
49	66.40.25	Nasal scissors · lower cutting edge toothed · curved right · 13,5 cm	1
50	66.40.26	Nasal scissors · lower cutting edge toothed · curved left · 13,5 cm	1

Part 2 ▶



TREVALLI

Sieb zur funktionellen endoskopischen Nasennebenhöhlen-Chirurgie
Set for Functional Endoscopic Paranasal Sinuses Surgery
Juego para cirugía endoscópica funcional del seno paranasal
Boîte chirurgie fonctionnelle endoscopique du sinus nasal
Set chirurgia funzionale del seno paranasale endoscopica

Part 2

SR	Item number	Description	Quantity
51	66.52.80	Sickle knife · sharp · 19 cm	1
52	66.52.81	Sickle knife · blunt · 19 cm	1
53	66.54.80	Double probe · ball end · 1,2 mm / 2,0 mm · 19 cm	1
54	66.58.20	FAULKNER Antrum curette · double-ended · 21,5 cm	1
55	66.58.80	Antrum curette · small · oval · 19 cm	1
56	66.58.87	Antrum curette · round · 5 mm · 20 cm	1
57	66.58.88	Antrum curette · oval · 3,0 × 6,0 mm · 20 cm	1
58	66.60.11	EICKEN Irrigation tube · Ø 3,0 mm · Luer · 15 cm	1
59	66.60.24	KILLIAN Irrigation tube · Luer · 3,5 mm · 15 cm	1
60	66.70.27	Sinuscope · Ø 2,7 mm · 70° · 175 mm	1
61	66.70.40	Sinuscope · Ø 4,0 mm · 0° · 175 mm	1
62	66.70.43	Sinuscope · Ø 4,0 mm · 30° · 175 mm	1
63	66.70.65	Sinuscope trocar · beaked point · Ø 4 mm	1
64	67.16.23	COTTLE Septum elevator · double-ended · 23 cm	1
65	68.82.32	KLUBA Orbital hook · medium · 19 cm	1
66	88.00.20	Bipolar connecting cable · Ø 12,5 mm · 3 m	1
67	88.00.40	Bracket · for high frequency cables · 22,5 cm	1
68	88.20.26	Coagulation forceps · bipolar · angular · blunt · 20 cm	1
69	91.10.12	Antifog solution · bottle · sterile · 30 ml	1
70	266.40.21	HEYMANN Nasal scissors · supercut · 18 cm	1
71	267.53.63	FOMON Nasal scissors · supercut plus · 13 cm	1
72	49.60.17	Mediccontainer · 590 × 290 × 170 mm · silver	1
73	49.97.06	Endoscope wire basket · 290 × 80 × 52 mm · for 2 endoscopes	1
74	49.97.21	Wire basket · 510 × 255 × 50 mm	3
75	49.97.82	Silicone mat · 13 mm · 467 × 240 mm	1



TREVALLi

Mikro-Ohrsieb
Micro Ear Set
Juego para micro otología
Boîte pour micro otologie
Set micro auricolare

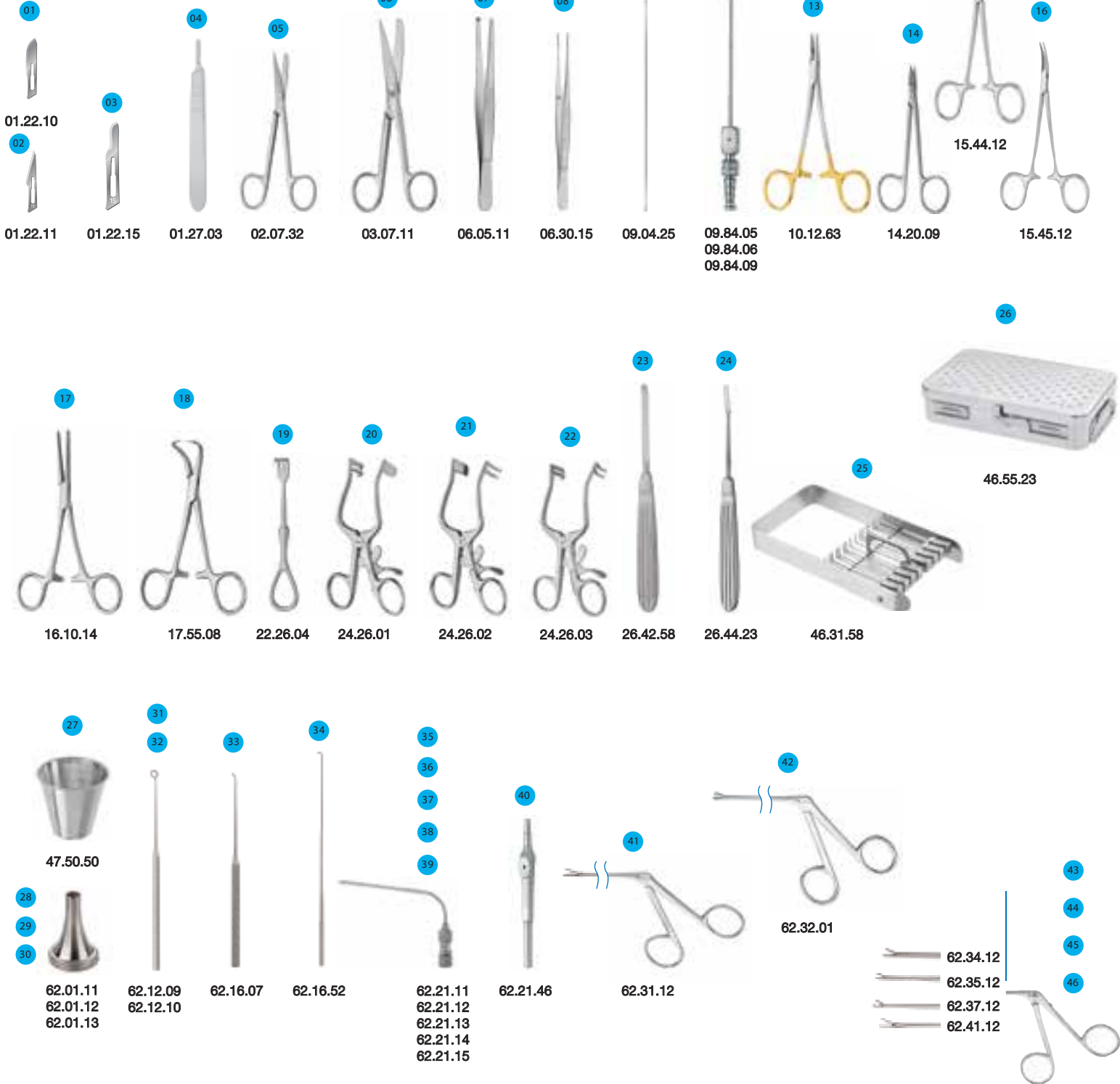



TREVALLi

Mikro-Ohrsieb
Micro Ear Set
Juego para micro otología
Boîte pour micro otologie
Set micro auricolare

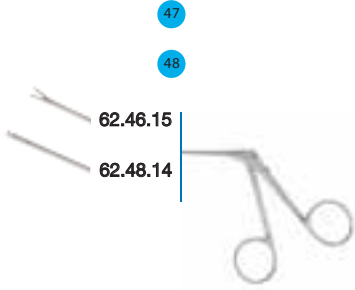

47
48

62.46.15
62.48.14

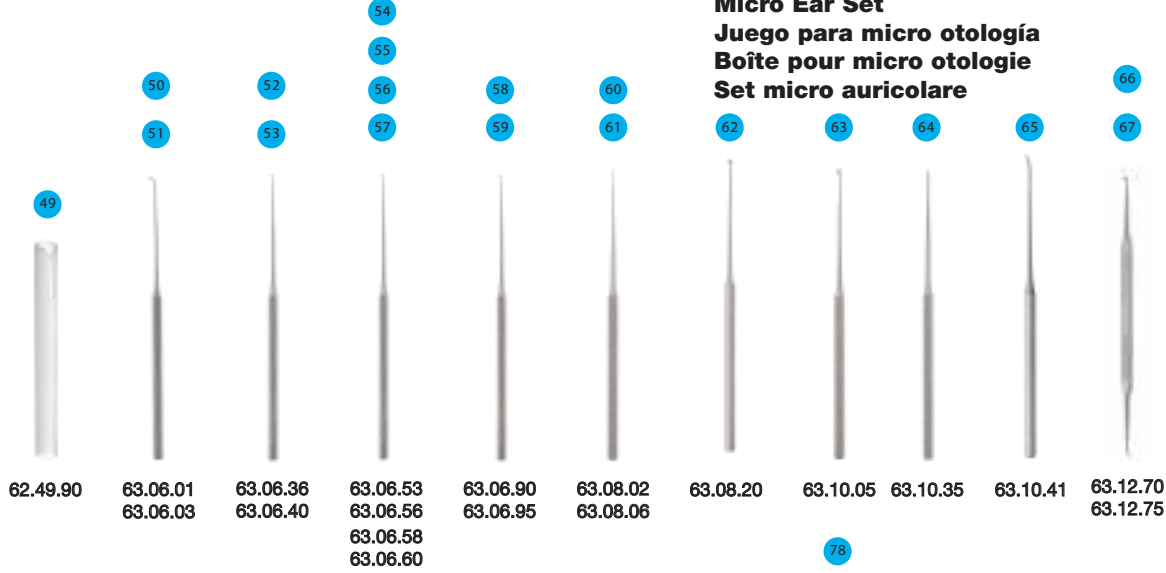

49 50 51 52 53 54 55 56 57 58 59 60 61 62 63 64 65 66 67
62.49.90 63.06.01 63.06.36 63.06.53 63.06.90 63.08.02 63.08.20 63.10.05 63.10.35 63.10.41 63.12.70
63.06.03 63.06.40 63.06.56 63.06.95 63.08.06 63.12.75
63.06.58 63.06.60



68 69 70 71 72 73 74 75 76 77 78 79
63.14.33 63.45.26 63.54.00 63.56.22 63.60.22 63.65.73 63.66.00 63.69.95 63.89.75 66.03.53 72.25.01 76.01.05

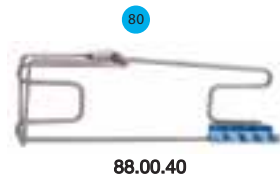

80

88.00.40



82

88.17.08



83

92.10.10



84

203.07.14



85

204.11.11



86

49.60.17



87

49.90.04



88

49.97.21



Part 1

SR	Item number	Description	Quantity
01	01.22.10	Scalpel blade · figure 10 · sterile · packing unit 100 pieces	1
02	01.22.11	Scalpel blade · figure 11 · sterile · packing unit 100 pieces	1
03	01.22.15	Scalpel blade · figure 15 · sterile · packing unit 100 pieces	1
04	01.27.03	Scalpel handle · no. 3 · standard · 12,5 cm	2
05	02.07.32	WAGNER Scissors · delicate · curved · sharp/blunt · 12 cm	1
06	03.07.11	Operating scissors · curved · sharp/blunt · 11,5 cm	1
07	06.05.11	Tissue forceps · 1 x 2 teeth · standard · 11,5 cm	1
08	06.30.15	SEMKEN Dressing forceps · straight · serrated · 15 cm	1
09	09.04.25	Probe · double-ended · Ø 1,5 mm · 25 cm	1
10	09.84.05	PLESTER Suction tube · 5 French · angled · 13,5 cm	1
11	09.84.06	PLESTER Suction tube · 6 French · angled · 13,5 cm	1
12	09.84.09	PLESTER Suction tube · 9 French · angled · 13,5 cm	1
13	10.12.63	HALSEY HM Needle holder · 13,5 cm	1
14	14.20.09	SCHUKNECHT Wire cutting scissors · 10 cm	1
15	15.44.12	HALSTED-MOSQUITO Hemostatic forceps · straight · 12,5 cm	1
16	15.45.12	HALSTED-MOSQUITO Hemostatic forceps · curved · 12,5 cm	2
17	16.10.14	PEAN Hemostatic forceps · straight · 14 cm	1
18	17.55.08	BACKHAUS Towel clamp · 8,5 cm	6
19	22.26.04	VOLKMANN Retractor · 4 teeth · sharp · 13 mm · 12 cm	1
20	24.26.01	BELUCCI Retractor · left 2 teeth · 11 cm	1
21	24.26.02	BELUCCI Retractor · right 2 teeth · 11 cm	1
22	24.26.03	PLESTER Retractor · 2 x 2 teeth · blunt · 11 cm	2
23	26.42.58	Raspatory · 8 mm · 17 cm	1
24	26.44.23	LEMPERT Raspatory · 3,0 mm · 17 cm	1
25	46.31.58	Sterilizing rack · 190 x 97 x 32 mm	1
26	46.55.23	Sterilizing case · 230 x 130 x 50 mm	1
27	47.50.50	Medicin cup · graduated · 50 ml	1
28	62.01.11	HARTMANN Ear speculum · adult · figure 1 - Ø 5,5 mm	1
29	62.01.12	HARTMANN Ear speculum · adult · figure 2 - Ø 6,5 mm	1
30	62.01.13	HARTMANN Ear speculum · adult · figure 3 - Ø 7,5 mm	1
31	62.12.09	BUCK Ear curette · sharp · figure 00 · 15 cm	1
32	62.12.10	BUCK Ear curette · sharp · figure 0 · 15 cm	1
33	62.16.07	WAGENER Ear lever · blunt · 14 cm	1
34	62.16.52	DAY Ear hook · large · 16 cm	1
35	62.21.11	ROSEN Suction needle · 0,7 mm · angled	4
36	62.21.12	ROSEN Suction needle · 0,9 mm · angled	4
37	62.21.13	ROSEN Suction needle · 1,2 mm · angled	4
38	62.21.14	ROSEN Suction needle · 1,5 mm · angled	4
39	62.21.15	ROSEN Suction needle · 2,0 mm · angled	4
40	62.21.46	WULLSTEIN Suction handle · Luer	1
41	62.31.12	HARTMANN Ear forceps · 8 cm	1
42	62.32.01	HARTMANN- HERZFELD Ear forceps · straight · Ø 2,0 mm · 8 cm	1
43	62.34.12	Micro ear forceps · serrated · straight · 4 x 0,5 mm · 8 cm	1
44	62.35.12	Micro ear forceps · serrated · straight · 4 x 0,4 mm · 8 cm	1
45	62.37.12	Micro ear forceps · straight · 1 x 0,9 mm · 8 cm	1
46	62.41.12	Micro ear scissors · sharp · straight · 8 cm	1

Part 2 ▶



Part 2

SR	Item number	Description	Quantity
47	62.46.15	MC GEE Wire bending forceps · 4,5 × 0,8 mm · 8 cm	1
48	62.48.14	DIETER Malleus punch · 8 cm	1
49	62.49.90	Ear forceps protector · t efl on	6
50	63.06.01	BARBARA Needle · straight · sharp · 15 cm	1
51	63.06.03	BARBARA Needle · curved · sharp · 15 cm	2
52	63.06.36	Hook · 45° · 0,6 mm · 15 cm	1
53	63.06.40	SHAMBAUGH Hook · 45° · 1,0 mm · 15 cm	1
54	63.06.53	Hook · 90° · 0,3 mm · 15 cm	1
55	63.06.56	Hook · 90° · 0,6 mm · 15 cm	2
56	63.06.58	Hook · 90° · 0,8 mm · 15 cm	1
57	63.06.60	SHAMBAUGH Hook · 90° · 1,0 mm · 15 cm	1
58	63.06.90	PLESTER Hook · 2 mm · 15 cm	1
59	63.06.95	ROSEN Fenestrator · 15 cm	1
60	63.08.02	FISCH Footplate hook · 0,2 mm · 15 cm	2
61	63.08.06	PLESTER Footplate hook · 0,6 mm · 15 cm	2
62	63.08.20	ANTOLI-CANDELA Round knife · Ø 2 mm · 45° · 15 cm	2
63	63.10.05	PLESTER Flap knife · 15 cm	2
64	63.10.35	Discision knife · straight · 15 cm	1
65	63.10.41	HOUSE Sickle knife · 6,0 × 1,5 mm · 16 cm	2
66	63.12.70	HOUSE Curette · double-ended · 1,0 / 1,2 mm · 15 cm	2
67	63.12.75	HOUSE Curette · double-ended · 1,5 / 1,8 mm · 15 cm	2
68	63.14.33	Wire guide · 15 cm	1
69	63.45.26	Hand piece · angled · 1:1 · 128 mm	1
70	63.54.00	Diamond burrs · 70 mm · set of 15 pieces · Ø 0,6 - 7 mm	1
71	63.56.22	Cutting burr barrel · 70 mm · 6,0 mm	1
72	63.60.22	Cutting burr bud · 70 mm · 6,0 mm	1
73	63.65.73	FISCH Perforator · 0,3 mm · 15 cm	1
74	63.66.00	HM Cutting burrs · set of 14 pieces · Ø 0,5 - 7 mm	1
75	63.69.95	Service cleaning oil · without adapter · 400 ml	1
76	63.89.75	SCHUKNECHT MODIF. Wire bending die	1
77	66.03.53	HARTMANN-HALLE Nasal speculum · fi gure 3 · 15 cm	1
78	72.25.01	SEIFFERT Salivary duct probe · 18 cm	1
79	76.01.05	Suture wire · soft · 0,5 mm · coil/10 m	1
80	88.00.20	Bipolar connecting cable · Ø 12,5 mm · 3 m	1
81	88.00.40	Bracket · for high frequency cables · 22,5 cm	1
82	88.17.08	Coagulation forceps · bipolar · angled · blunt · 16,5 cm	1
83	92.10.10	Micro motor system Servotronic EC 100 · 230 V	1
84	203.07.14	Operating scissors · supercut · curved · sharp/blunt · 14,5 cm	1
85	204.11.11	SIEGERT Scissors · supercut · curved · 11,5 cm	1
86	49.60.17	Medicontainer · 590 × 290 × 170 mm · silver	1
87	49.90.04	Tray · with fixation strips · for 12 instruments	2
88	49.97.21	Wire basket · 510 × 255 × 50 mm	1



TREVALLi

Myringotomiesieb
Myringotomy Set
Juego para miringotomía
Boîte pour myringotomie
Set per miringotomia

01



09.21.15

02



62.01.03

03

04



62.01.12
62.01.13

05



62.13.11

06



62.18.35

07

08

09



62.21.01
62.21.02
62.21.03

10



62.21.48

11



62.34.12

12



63.06.055

13



63.06.516

14



63.10.41

15



49.40.335

16



49.97.10

17



49.97.74



TREVALLi

**Myringotomiesieb
Myringotomy Set
Juego para miringotomía
Boîte pour myringotomie
Set per miringotomia**

SR	Item number	Description	Quantity
01	09.21.15	LATHBURY (FARRELL) Cotton carrier · Ø 1,2 mm · cross threads · 15 cm	1
02	62.01.03	HARTMANN Ear speculum · child · figure 3 - 5 5 mm	1
03	62.01.12	HARTMANN Ear speculum · adult · figure 2 - 6 5 mm	1
04	62.01.13	HARTMANN Ear speculum · adult · figure 3 - 7 5 mm	1
05	62.13.11	BUCK Ear curette · blunt · figure 1 · 15 cm	1
06	62.18.35	LUCAE Tympanum perforator	1
07	62.21.01	ROSEN Suction needle · 0 7 mm · straight · Luer-Lock	1
08	62.21.02	ROSEN Suction needle · 0,9 mm · straight · Luer-Lock	1
09	62.21.03	ROSEN Suction needle · 1,2 mm · straight · Luer-Lock	1
10	62.21.48	Tube connector · Luer	1
11	62.34.12	Micro ear forceps · serrated · straight · 4 × 0,5 mm · 8 cm	1
12	63.06.05	Needle · curved · blunt · 15 cm	1
13	63.06.56	Hook · 90° · 0,6 mm · 15 cm	1
14	63.10.41	HOUSE Sickle knife · 6,0 × 1,5 mm · 15 cm	1
15	49.40.35	Mediccontainer · 300 135 47 mm · silver	1
16	49 97 10	ire basket · small · with handle · 275 125 40 mm	1
17	49 97 74	Silicone mat · 3 mm · 265 × 115 mm	1



TREVALLi

Paukendrainage-Sieb
Drainage Set for Tympanic Cavity
Juego para el drenaje timpanico
Boîte de drainage pour tympan
Set per il drenaggio timpanico

- 01
- 02
- 03
- 04
- 05



46.31.58



62.01.11
62.01.12
62.01.13

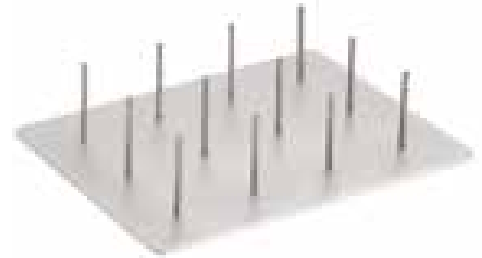

62.03.65

06



62.13.11

07

08



62.21.41
62.21.42

09



62.21.48

10



62.34.12

11



63.06.03

12



63.06.58

13



63.10.41

14



49.50.15

15



49.97.02



TREVALLi

Paukendrainage-Sieb
Drainage Set for Tympanic Cavity
Juego para el drenaje timpanico
Boîte de drainage pour tympan
Set per il drenaggio timpanico

SR	Item number	Description	Quantity
01	46.31.58	Sterilizing rack · 190 × 97 × 32 mm	1
02	62.01.11	HARTMANN Ear speculum · for adults · figure 1 · 5.5 mm	1
03	62.01.12	HARTMANN Ear speculum · for adults · figure 2 · 6.5 mm	1
04	62.01.13	HARTMANN Ear speculum · for adults · figure 3 · 7.5 mm	1
05	62.03.65	Rack · for 12 ear specula	1
06	62.13.11	BUCK Ear curette · blunt · figure 1 · 15 cm	1
07	62.21.41	WULLSTEIN Suction tube · 1.5 mm · silver · 16 cm	1
08	62.21.42	WULLSTEIN Suction tube · 2.0 mm · silver · 16 cm	1
09	62.21.48	Tube connector · Luer	1
10	62.34.12	Micro ear forceps · serrated · straight · 4.05 mm · 8 cm	1
11	63.06.03	BARBARA Needle · curved · sharp · 15 cm	1
12	63.06.58	Hook · 90° · 0.8 mm · 15 cm	1
13	63.10.41	HOUSE Sickle knife · 6.0 · 1.5 mm · 15 cm	1
14	49.50.10	Mediccontainer · 290 × 290 × 100 mm	1
15	49.97.02	Wire basket · 240 × 255 × 50 mm	1



TREVALLi

Anthelix-Otoplastiksieb
Anthelix Otoplastic Set
Juego anthelix para otoplastia
Boîte anthelix pour otoplastie
Set anthelix per otoplastica

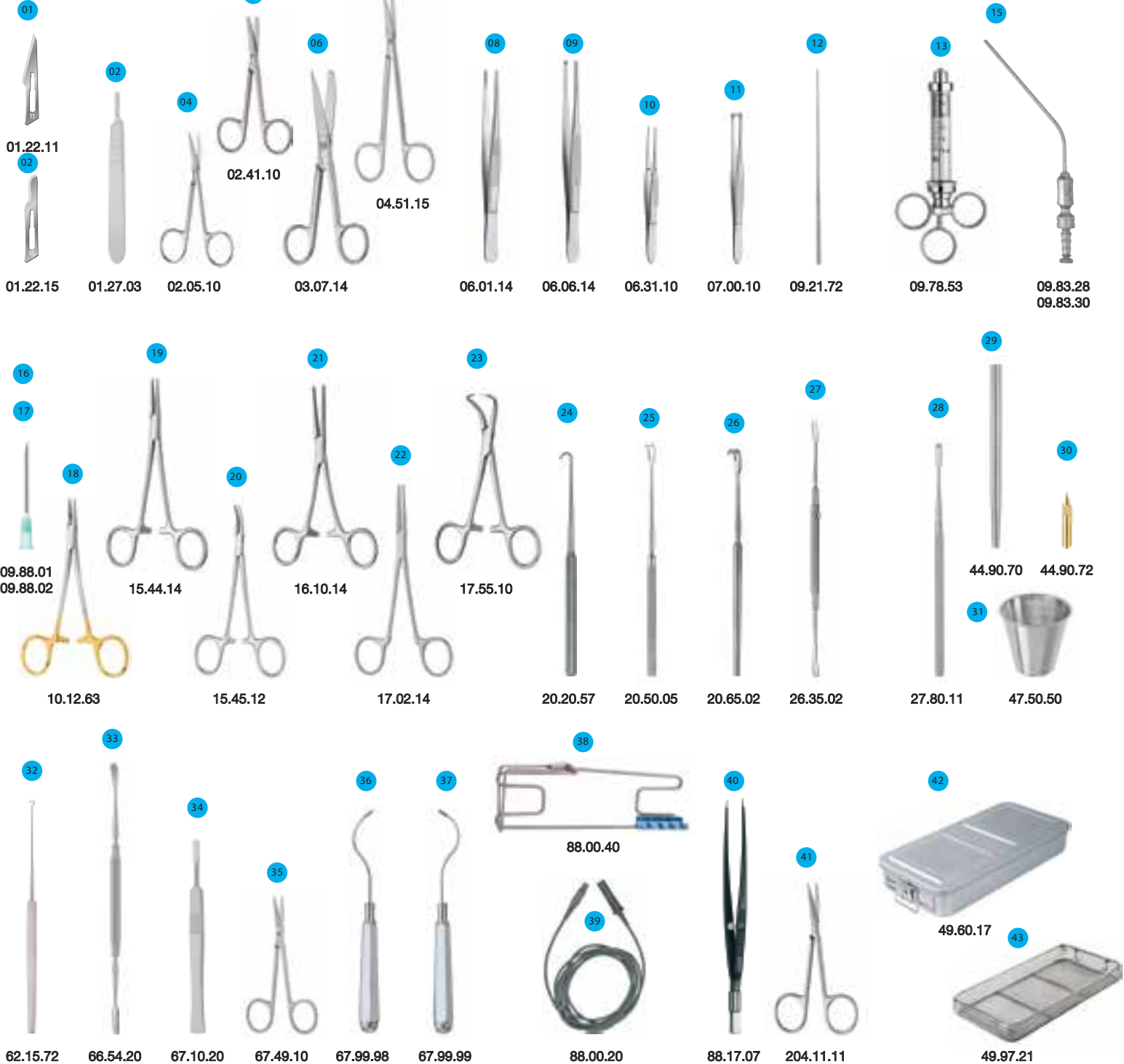



TREVALLI

Anthelix-Otoplastiksieb
Anthelix Otoplastic Set
Juego anthelix para otoplastía
Boîte anthelix pour otoplastie
Set anthelix per otoplastica

SR	Item number	Description	Quantity
01	01.22.11	Scalpel blade · figure 11 · sterile · packing unit 100 pieces	1
02	01.22.15	Scalpel blade · figure 15 · sterile · packing unit 100 pieces	1
03	01.27.03	Scalpel handle · no. 3 · standard · 12,5 cm	1
04	02.05.10	Scissors · curved · sharp · 10,5 cm	1
05	02.41.10	LEXER-BABY Scissors · curved · 10 cm	1
06	03.07.14	Operating scissors · curved · sharp/blunt · 14,5 cm	1
07	04.51.15	JOSEPH Scissors · curved · 15 cm	1
08	06.01.14	Dressing forceps · medium · 14,5 cm	1
09	06.06.14	Tissue forceps · 1 × 2 teeth · medium · 14,5 cm	1
10	06.31.10	Iris forceps · straight · 1 × 2 teeth · 10 cm	1
11	07.00.10	GRAEFE Fixation forceps · straight · 11 cm	1
12	09.21.72	Cotton carrier · Ø 1,2 mm · triangular serrated · 12 cm	1
13	09.78.53	Hypodermic syringe · 5 ml · Luer-Lock	1
14	09.83.28	FRAZIER (FERGUSON) Suction cannula · 8 French · angled · 12,5 cm	1
15	09.83.30	FRAZIER (FERGUSON) Suction cannula · 10 French · angled · 12,5 cm	1
16	09.88.01	Injection cannula · Ø 1,2 × 40 mm · packing unit 100 pieces	1
17	09.88.02	Injection cannula · Ø 1,2 × 60 mm · packing unit 100 pieces	1
18	10.12.63	HALSEY HM Needle holder · serrated · 13,5 cm	1
19	15.44.14	HALSTED-MOSQUITO Hemostatic forceps · straight · 14 cm	1
20	15.45.12	HALSTED-MOSQUITO Hemostatic forceps · curved · 12,5 cm	6
21	16.10.14	PEAN Hemostatic forceps · straight · 14 cm	1
22	17.02.14	Dissecting forceps · without catch · 14 cm	1
23	17.55.10	BACKHAUS Towel clamp · 10,5 cm	6
24	20.20.57	Nerve and tendon hook · 7 mm · blunt · 16 cm	1
25	20.50.05	JOSEPH Hook · 2 teeth · 5 mm · 17 cm	1
26	20.65.02	Tracheal retractor · 2 teeth · blunt · 8 mm · 16 cm	1
27	26.35.02	FREER Elevator · sharp/blunt · 5 mm · 19 cm	1
28	27.80.11	FREER Chisel · slightly curved · 4 mm · 17 cm	1
29	44.90.70	Pen holder · 13 cm	1
30	44.90.72	Feather · for high frequency cables · 22,5 cm	1
31	47.50.50	Medicine cup · 50 ml	1
32	62.15.72	HARTMANN Ear hook · sharp · figure 2 · 16 cm	1
33	66.54.20	FREER-JOSEPH Septum elevator · double-ended · 19,5 cm	1
34	67.10.20	COTTLE Septum knife · straight · 14 cm	1
35	67.49.10	COTTLE-MASING Nasal scissors · curved · blunt · 10cm	1
36	67.99.98	KISTLER Anthelix cartilage rasp · right · 16 cm	1
37	67.99.99	KISTLER Anthelix cartilage rasp · left · 16 cm	1
38	88.00.20	Bipolar connecting cable · Ø 12,5 mm · 3 m	1
39	88.00.40	Bracket · no. 46 · for marking · packing unit 100 piece	1
40	88.17.07	Coagulation forceps · bipolar · angled · sharp · 16,5 cm	1
41	204.11.11	SIEGERT Scissors · supercut · curved · 11,5 cm	1
42	49.60.13	Medicontainer · 590 × 290 × 135 · silver	1
43	49.97.21	Wire basket · 510 × 255 × 50 mm	2

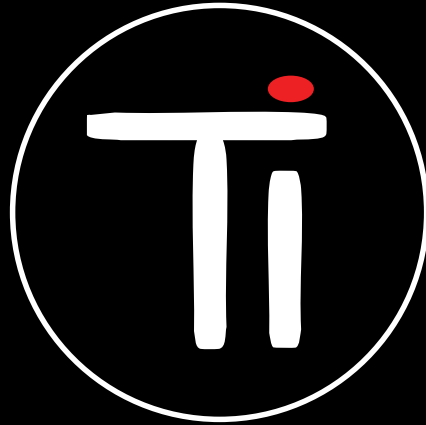

TREVALLi

tomorros solutions . . . today!

 083 555 8643

@ trevalli@mweb.co.za

 3 Oldham Place,
Pietermaritzburg



Postnet suite #A02,
Private Bag X8,
Cascades, 3202